



Department of
Building and Housing
Te Tari Kaupapa Whare

Dear Customer

Please find enclosed Amendment 5, effective 10 October 2011, to the Compliance Document for Clause D1 Access Routes of the New Zealand Building Code.

You should have this version of the amendment if you purchased your copy of D1 from Standards New Zealand prior to July 2001.

Section	Old D1	October 2011 Amendments to D1
Title page	Remove title page and document history	Replace with new title page and document history
Code Clause D1	Remove page iii-vi	Replace with new page iii-vi
Contents/References	Remove page vii/viii	Replace with new page vii/viii
Definitions	Remove page ix/x	Replace with new page ix/x
D1/AS1	Remove pages 27/28, 31/32	Replace with new pages 27/28, 31/32
Index	Remove pages 33-38	Replace with new pages 33-36

Compliance Document for New Zealand Building Code Clause D1 Access Routes – Second Edition

Prepared by the Department of Building and Housing

This Compliance Document is prepared by the Department of Building and Housing. The Department of Building and Housing is a Government Department established under the State Sector Act 1988.

Enquiries about the content of this document should be directed to:



Department of
Building and Housing
Te Tari Kaupapa Whare

Department of Building and Housing
PO Box 10-729, Wellington.
Telephone 0800 242 243
Fax 04 494 0290
Email: info@dbh.govt.nz

Compliance Documents are available from www.dbh.govt.nz

New Zealand Government

© Department of Building and Housing 2011

This Compliance Document is protected by Crown copyright, unless indicated otherwise. The Department of Building and Housing administers the copyright in this document. You may use and reproduce this document for your personal use or for the purposes of your business provided you reproduce the document accurately and not in an inappropriate or misleading context. You may not distribute this document to others or reproduce it for sale or profit.

The Department of Building and Housing owns or has licences to use all images and trademarks in this document. You must not use or reproduce images and trademarks featured in this document for any purpose (except as part of an accurate reproduction of this document) unless you first obtain the written permission of the Department of Building and Housing.

Status of Compliance Documents

Compliance Documents are prepared by the Department of Building and Housing in accordance with section 22 of the Building Act 2004. A Compliance Document is for use in establishing compliance with the New Zealand Building Code.

A person who complies with a Compliance Document will be treated as having complied with the provisions of the Building Code to which the Compliance Document relates. However, a Compliance Document is only one method of complying with the Building Code. There may be alternative ways to comply.

Users should make themselves familiar with the preface to the New Zealand Building Code Handbook, which describes the status of Compliance Documents and explains alternative methods of achieving compliance.

Defined words (italicised in the text) and classified uses are explained in Clauses A1 and A2 of the Building Code and in the Definitions at the start of this Compliance Document.

D1: Document History			
	Date	Alterations	
First published	July 1992		
Amendment 1	December 1993	p. 12, Table 5 p. 15, 4.4.2, 4.5.2	p. 30, 12.0, 12.1
Amendment 2	19 August 1994	pp. i and ii, Document History p. vii, Contents p. viii, References pp. ix and x, Definitions p. 1, 1.0, 1.0.1, 1.0.2 p. 3, 1.2.1 p. 4, Figure 2 p. 6, 1.7.1 p. 6A, 2.1.1, 2.1.2, 2.1.3, 2.1.4 pp. 6B, 6C, 6D, Table 1A p. 6D, 2.2.1	p. 7, 3.1.4 p. 10, Figure 11 p. 11, 4.1.3 p. 12, Table 5, 4.1.4, 4.1.8 p. 13, 4.4, 4.4.1 p. 14, Figure 17 p. 15, 4.4.3 deleted, Figure 18, 4.5, 4.5.1, 4.5.2, 4.6, 4.6.1, 4.6.2 p. 10, Table 1A pp. 33 to 35, Index
Amendment 3	1 December 1995	p. ii, Document History p. viii, References	p. 15, 5.1.1
Second edition	28 February 1998	Document revised – second edition issued	
Amendment 4	1 July 2001	p. 2, Document History, Status p. 11, References p. 13, Definitions	p. 25, Figure 8 p. 30, 4.2.1 Comment p. 41, 6.0.7 Comment p. 46, 12.0.1
Amendment 5	10 October 2011	p. 2, Document History, Status pp. iii–iv, Code Clause D1 p. vii, Contents p. viii, References	p. ix, Definitions p. 27, D1/AS1 6.0.7 p. 32, D1/AS1 11.0 pp. 33–36, Index
Note: Page numbers relate to the document at the time of Amendment and may not match page numbers in current document.			

Document Status

The most recent version of this document, as detailed in the Document History, is approved by the Chief Executive of the Department of Building and Housing. It is effective from 10 October 2011 and supersedes all previous versions of this document.

People using this Compliance Document should check for amendments on a regular basis. The Department of Building and Housing may amend any part of any Compliance Document at any time. Up-to-date versions of Compliance Documents are available from www.dbh.govt.nz

New Zealand Building Code

Clause D1 Access Routes

This Clause is extracted from the New Zealand Building Code contained in the First Schedule of the Building Regulations 1992.

28	<i>Building Regulations 1992</i>	1992/150
FIRST SCHEDULE— <i>continued</i>		
Clause D1—ACCESS ROUTES		
Provisions	Limits on application	
OBJECTIVE		
D1.1 The objective of this provision is:		
<ul style="list-style-type: none"> (a) Safeguard people from injury during movement into, within and out of <i>buildings</i>, (b) Safeguard people from injury resulting from the movement of vehicles into, within and out of <i>buildings</i>, and (c) Ensure that <i>people with disabilities</i> are able to enter and carry out normal activities and functions within <i>buildings</i>. 	<p>Objective D1.1(c) shall apply only to those <i>buildings</i> to which section 47A of the Act applies.</p>	
FUNCTIONAL REQUIREMENT		
D1.2.1 <i>Buildings</i> shall be provided with reasonable and adequate access to enable safe and easy movement of people.		
D1.2.2 Where a <i>building</i> is provided with loading or parking spaces, they shall be constructed to permit safe and easy unloading and movement of vehicles, and to avoid conflict between vehicles and pedestrians.		
PERFORMANCE		
D1.3.1 <i>Access routes</i> shall enable people to:		
<ul style="list-style-type: none"> (a) Safely and easily approach the main entrance of <i>buildings</i> from the apron or <i>construction edge</i> of a <i>building</i>, (b) Enter <i>buildings</i>, (c) Move into spaces within <i>buildings</i> by such means as corridors, doors, stairs, ramps and lifts, (d) Manoeuvre and park cars, and (e) Manoeuvre and park delivery vehicles required to use the loading space. 	<p>Requirement D1.2.1 shall not apply to <i>Ancillary buildings</i> or <i>Outbuildings</i>.</p>	

Note: Section 47A is in the Building Act 1991. The equivalent section in the Building Act 2004 is section 118.

Effective from 29 December 2000

1992/150

Building Regulations 1992

29

FIRST SCHEDULE—*continued*

Provisions

D1.3.2 At least one *access route* shall have features to enable *people with disabilities* to:

- (a) Approach the *building* from the street boundary or, where required to be provided, the *building car park*,
- (b) Have access to the internal space served by the principal access, and
- (c) Have access to and within those spaces where they may be expected to work or visit, or which contain facilities for personal hygiene as required by Clause G1 “Personal Hygiene”.

D1.3.3 Access routes shall:

- (a) Have *adequate* activity space,
- (b) Be free from dangerous obstructions and from any projections likely to cause an obstruction,
- (c) Have a safe cross fall, and safe slope in the direction of travel,
- (d) Have *adequate* slip-resistant walking surfaces under all conditions of normal use,
- (e) Include stairs to allow access to upper floors irrespective of whether an escalator or lift has been provided,
- (f) Have stair treads, and ladder treads or rungs which:
 - (i) provide *adequate* footing, and
 - (ii) have uniform rise within each flight and for consecutive flights,
- (g) Have stair treads with a leading edge that can be easily seen,

Limits on application

Performance D1.3.2 shall not apply to *Housing, Outbuildings, backcountry huts, Ancillary buildings*, and to *Industrial buildings* where no more than 10 people are employed.

Effective from
31 October 2008

FIRST SCHEDULE—*continued*

Provisions	Limits on application
(h) Have stair treads which prevent children falling through or becoming held fast between treads, where open risers are used,	Performance D1.3.3 (h) shall not apply within <i>Industrial buildings, Outbuildings and Ancillary buildings.</i>
(i) Not contain isolated steps,	Performance D1.3.3 (i) shall not apply with <i>Detached Dwellings</i> or within <i>household units of Multi-unit Dwellings</i> , or to <i>Outbuildings and Ancillary buildings.</i>
(j) Have smooth, reachable and graspable <i>handrails</i> to provide support and to assist with movement along a stair or ladder,	Performance D1.3.3 (j) shall not apply to isolated steps.
(k) Have <i>handrails of adequate</i> strength and rigidity as required by Clause B1 "Structure",	
(l) Have landings of appropriate dimensions and at appropriate intervals along a stair or ramp to prevent undue fatigue,	
(m) Have landings of appropriate dimensions where a door opens from or onto a stair, ramp or ladder so that the door does not create a hazard, and	
(n) Have any automatically controlled doors <i>constructed</i> to avoid the risk of people becoming caught or being struck by moving parts.	
D1.3.4 An <i>accessible route</i> , in addition to the requirement of Clause D1.3.3, shall:	
(a) Be easy to find, as required by Clause F8 "Signs",	
(b) Have <i>adequate</i> activity space to enable a person in a wheelchair to negotiate the route while permitting an ambulant person to pass,	

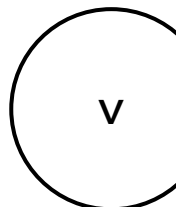

1992/150

Building Regulations 1992

31

FIRST SCHEDULE—*continued*

Provisions	Limits on application
<p>(c) Include a lift complying with Clause D2 “Mechanical Installations for Access” to upper floors where:</p> <p>(i) <i>buildings</i> are four or more storeys high,</p> <p>(ii) <i>buildings</i> are three storeys high and have a total design occupancy of 50 or more persons on the two upper floors,</p> <p>(iii) <i>buildings</i> are two storeys high and have a total design occupancy of 40 or more persons on the upper floor, or</p> <p>(iv) an upper floor, irrespective of design occupancy, is to be used for the purposes of public reception areas of banks, central, regional and local government offices and facilities, hospitals, medical and dental surgeries, and medical, paramedical and other primary health care centres,</p> <p>(d) Contain no thresholds or upstands forming a barrier to an unaided wheelchair user,</p> <p>(e) Have means to prevent the wheel of a wheelchair dropping over the side of the <i>accessible route</i>,</p> <p>(f) Have doors and related hardware which are easily used,</p> <p>(g) Not include spiral stairs, or stairs having open risers,</p> <p>(h) Have stair treads with leading edge which is rounded, and</p>	

Contents

	Page		Page
References	viii	7.0 Doors and Openings	29
Definitions	ix	8.0 Places of Assembly	29
Verification Method D1/VM1	1	8.1 Spaces for wheelchairs	29
1.0 Slip Resistance	1	8.2 Access to performance areas	29
Acceptable Solution D1/AS1	3	9.0 Accessible Accommodation	29
1.0 General Criteria	3	Units of Communal Residential Buildings	
1.1 Location	3	9.1 Number of units to be provided	29
1.2 Slope	3	9.2 Facilities to be provided	31
1.3 Changes in level	3	10.0 Movement of Vehicles	32
1.4 Height clearances	4	10.1 Car parking areas	32
1.5 Obstructions	4	10.2 Modifications to AS 2890	32
1.6 Structural stability	5	11.0 Other Acceptable Solutions	32
1.7 Barriers	7	12.0 Lifts	32
1.8 Lighting	7	Index	33
2.0 Level Access Routes	7		
2.1 Slip resistance	11		
2.2 Width	11		
2.3 Protection from falling	11		
3.0 Ramps	11		
3.1 Slope	11		
3.2 Width	12		
3.3 Landings	12		
3.4 Kerb ramps	13		
4.0 Stairways	13		
4.1 Pitch, risers and treads	13		
4.2 Width	16		
4.3 Landings	17		
4.4 Curved and spiral stairways	19		
4.5 Stair winders	19		
4.6 Visibility of stair treads	19		
5.0 Fixed Ladders	20		
5.1 General	20		
5.2 Step-type ladders	23		
5.3 Rung-type ladders	24		
5.4 Individual rung-type ladders	25		
6.0 Handrails	25		

Amend 5
Oct 2011

References

Amend 4
Jul 2001

For the purposes of New Zealand Building Code (NZBC) compliance, the Standards and documents referenced in this Compliance Document (primary reference documents) must be the editions, along with their specific amendments, listed below. Where these primary reference documents refer to other Standards or documents (secondary reference documents), which in turn may also refer to other Standards or documents, and so on (lower-order reference documents), then the version in effect at the date of publication of this Compliance Document must be used.

Amend 5
Oct 2011

Standards New Zealand

		Where quoted
	NZS/AS 1657: 1992 Fixed platforms, walkways, stairways and ladders – Design, construction and installation (known as the SAA Code for fixed platforms, walkways, stairways, and ladders)	AS1 11.0.3
	NZS 3114: 1987 Specification for concrete surface finishes <i>Amend: 1</i>	AS1 Table 2
Amend 5 Oct 2011	NZS 3116: 2002 Concrete segmental and flagstone paving <i>Amend: 1</i>	AS1 Table 2
Amend 4 Jul 2001	NZS 4121: 2001 Design for access and mobility – Buildings and associated facilities	AS1 11.0.1, 12.0.2

Standards Australia

	AS 2890:- Part 1: 2004 Parking facilities Off street parking <i>Amend: 1</i>	AS1 10.1, 10.2
Amend 5 Oct 2011	Part 2: 2002 Off street commercial facilities <i>Amend: 1</i>	AS1 11.0.2
	AS/NZS 3661:- Part 1: 1993 Slip resistance of pedestrian surfaces Requirements	VM1 1.0.2, AS1 2.1.1, 3.1.4, Table 2
	Part 2: 1994 Guide to the reduction of slip hazards	AS1 2.1.3

British Standards Institution

	BS 585:- Part 1: 1989 Wood stairs. Specification for stairs with closed risers for domestic use, including straight and winder flights and quarter or half landings	AS1 4.5.3
	BS 5395:- Part 2: 1984 Stairs, ladders and walkways Code of practice for the design of helical and spiral stairs	AS1 4.4.1

Definitions

This is an abbreviated list of definitions for words or terms particularly relevant to this Compliance Document. The definitions for any other italicised words may be found in the New Zealand Building Code Handbook.

Amend 5
Oct 2011

Access route A continuous route that permits people and goods to move between the apron or construction edge of the *building* to spaces within a *building*, and between spaces within a *building*.

Accessible Having features to permit use by *people with disabilities*.

Accessible route An *access route* usable by *people with disabilities*. It shall be a continuous route that can be negotiated unaided by a wheelchair user. The route shall extend from street boundary or car parking area to those spaces within the *building* required to be *accessible* to enable *people with disabilities* to carry out normal activities and processes within the *building*.

Accessible stairway A *stairway* having features for use by *people with disabilities*. *Buildings* required to be *accessible* shall have at least one *accessible stairway* leading off an *accessible route* whether or not a lift is provided.

Adequate *Adequate* to achieve the objectives of the *building code*.

Building has the meaning given to it by sections 8 and 9 of the *Building Act 2004*.

Amend 5
Oct 2011

Common ramp A ramp which is used, or intended to be used by the public whether as of right or not, and is not a *service ramp* or *accessible ramp*.

Common stairway A *stairway* which is used, or intended to be used, by the public whether as of right or not, and is not a *private stairway*, *service stairway* or *accessible stairway*.

Handrail A rail to provide support to, or assist with the movement of a person.

Household unit

(a) means a *building* or group of *buildings*, or part of a *building* or group of *buildings*, that is—

- (i) used, or intended to be used, only or mainly for residential purposes; and
- (ii) occupied, or intended to be occupied, exclusively as the home or residence of not more than 1 household; but

(b) does not include a hostel, boarding house, or other specialised accommodation.

Amend 5
Oct 2011

Kerb ramp means a short ramp either cutting through a kerb or built up to the kerb.

Main private stairway A *private stairway* intended to provide access to and between frequently used spaces such as living areas, kitchens and garages, and includes all exterior *private stairways*.

Minor private stairway A *private stairway* not on a main thoroughfare, and intended to provide infrequent access to a single room which is not a living area or kitchen.

Nosing The rounded projecting edge of a stair tread.

Person with a disability means a *person* who has an impairment or a combination of impairments that limits the extent to which the *person* can engage in the activities, pursuits, and processes of everyday life, including, without limitation, any of the following:

- (a) a physical, sensory, neurological, or intellectual impairment;
- (b) a mental illness.

Amend 4
Jul 2001

Amend 5
Oct 2011

Pitch line The line joining the leading edge or *nosings* (if any) of successive stair treads within a single flight of a *stairway*.

Private stairway A *stairway* used, or intended to be used, by the occupants of a single *household unit*.

Secondary private stairway A *private stairway* other than a *main* or *minor private stairway*, intended to provide access to another floor containing only bedrooms, bathroom or similar accommodation

Service ramp means a ramp that is used, or intended to be used, infrequently by service personnel to gain access to spaces for the purposes of maintenance and the movement of goods.

Service stairway means a *stairway* that is used, or intended to be used, infrequently by service personnel to gain access to spaces for the purposes of maintenance and the movement of goods.

Stairway A series of steps or stairs with or without landings, including all necessary *handrails* and giving access between two different levels.

Threshold A sill to an external door, or the floor under an internal door.

Verification Method D1/VM1

1.0 Slip Resistance

1.0.1 Compliance with the slip-resistant performance of NZBC D1.3.3 (d) may be verified by confirming that the walking surface under the expected conditions of use has a coefficient of friction (μ) of no less than:

$$\mu = 0.4 + 0.0125 S$$

where S is the slope of the walking surface expressed as a percentage.

1.0.2 Measurement of the coefficient of friction shall be in accordance with AS/NZS 3661.1.

6.0.2 Any *stairway* which exceeds 2.0 m in width shall:

- a) Have *handrails* on both sides and, where the width exceeds 4.0 m, shall also have an intermediate *handrail* provided at the centre of the *stairway*, or
- b) If the *stairway* is essentially an outdoor architectural feature and not required to be an **accessible stairway**, have at least one *handrail*. Examples of such *stairways* are those leading to civic areas, or to decks on *Housing*.

COMMENT:

A central rail gives all users a rail to use for safety purposes. On *stairways* in public *buildings*, such as sports stadia, intermediate rails are also effective for crowd control. The 2.0 m width is a comfortable width for three people, two of whom can grasp a rail if anyone trips.

6.0.3 Accessible stairways and accessible ramps – *Handrails* shall be provided on both sides of *accessible stairways* and on both sides of *accessible ramps* where the ramp slope is steeper than 1 in 20. The *handrails* shall be continuous except where doors are located on landings (see Figures 9 and 25).

6.0.4 Slope of handrails – *Handrails* shall have the same slope as the *pitch line*, begin no further than the second riser from the lower end of the *stairway*, and extend the full length of the *stairway* they serve. Except that, where the *handrail* serves an *accessible stairway* or *accessible ramp*, a 300 mm (minimum) horizontal extension shall be provided at each end of the *handrail*, as shown in Figures 9 and 25.

6.0.5 The first riser shall be located a sufficient distance back from the corner where the two walls meet, to accommodate the extended *handrail*, as shown in Figure 25.

6.0.6 Height of handrails – *Handrails* shall be positioned between 900 mm and 1 m above the *pitchline* (see Figure 25).

6.0.7 Handrail profiles – *Handrails* shall have a profile which can be readily grasped by an adult hand and shall be installed in a way that avoids the likelihood of personal injury. An acceptable *handrail* shall be shaped and

located to ensure that, under normal usage, a person's hand will not contact adjacent walls, supporting brackets or fixings, or any other obstruction.

COMMENT:

It is important that in the event of stumbling on a *stairway* or ramp an adult, even with a small hand, can firmly grasp the *handrail* to prevent a fall.

Amends
4 and 5

6.0.8 A graspable *handrail* profile shall have:

- a) A flat or convex upper surface,
- b) Arrised or radiused edges,
- c) A minimum cross section width of 20 mm, and
- d) A "relevant width" (as illustrated in Figure 26 (a)) across the top surface of no greater than 80 mm. Figure 26 (a) and (b) indicates some acceptable profiles but others may also be acceptable.

6.0.9 Acceptable *handrail* profiles for *accessible stairways* and *accessible ramps* are shown in Figure 26 (b).

COMMENT:

In most circumstances a *handrail* is used with a light grip to steady the user of a *stairway* or ramp. Ambulant *people with disabilities* use *handrails* for both leverage and support, and wheelchair users often need to firmly grip the rails to pull themselves along, particularly on ramps. In those circumstances a profile offering an adequate grip is important.

Figure 26: Handrail Profiles and Clearances
Paragraphs 6.0.8 and 6.0.9

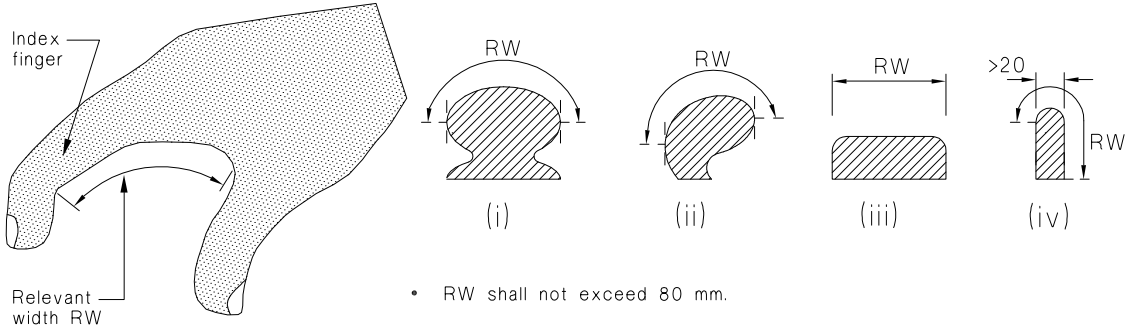

- RW shall not exceed 80 mm.
- RW (relevant width) is measured around the upper surface perimeter of the handrail section between the vertical tangents on either side.
- Variations in shape are acceptable provided the effective grip is not reduced. For example, the side faces shown as vertical in details (iii) and (iv) are still acceptable even if slightly curved or sloped up to 5° from vertical.
- See fig. 26 (b) for wall clearances.

(a) Determination of relevant width for private and common stairways

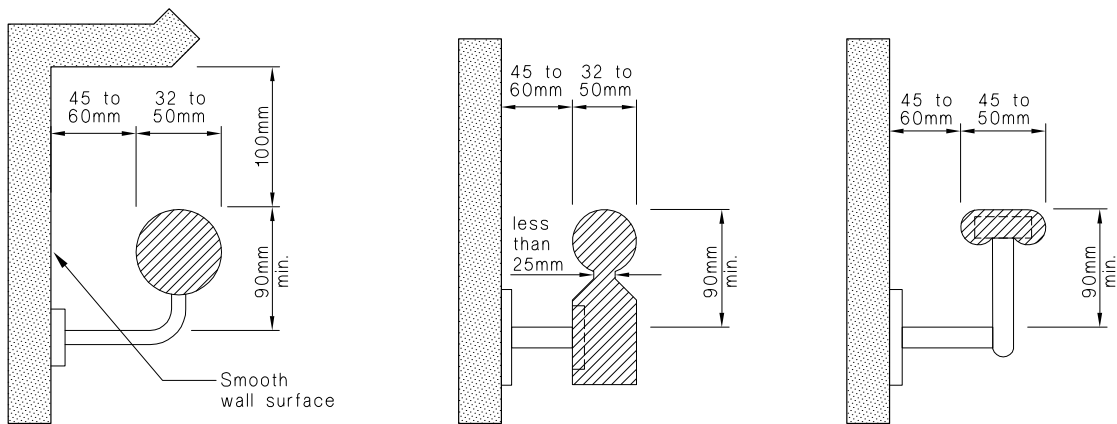

The profiles shown comply with the provisions for accessible handrails.

The clearances apply to all handrails and the maximum dimension must be used for rough textured wall surfaces.

(b) Acceptable profiles and clearances for accessible stairways

Figure 30: Seating Spaces for Wheelchairs
Paragraph 8.1.2

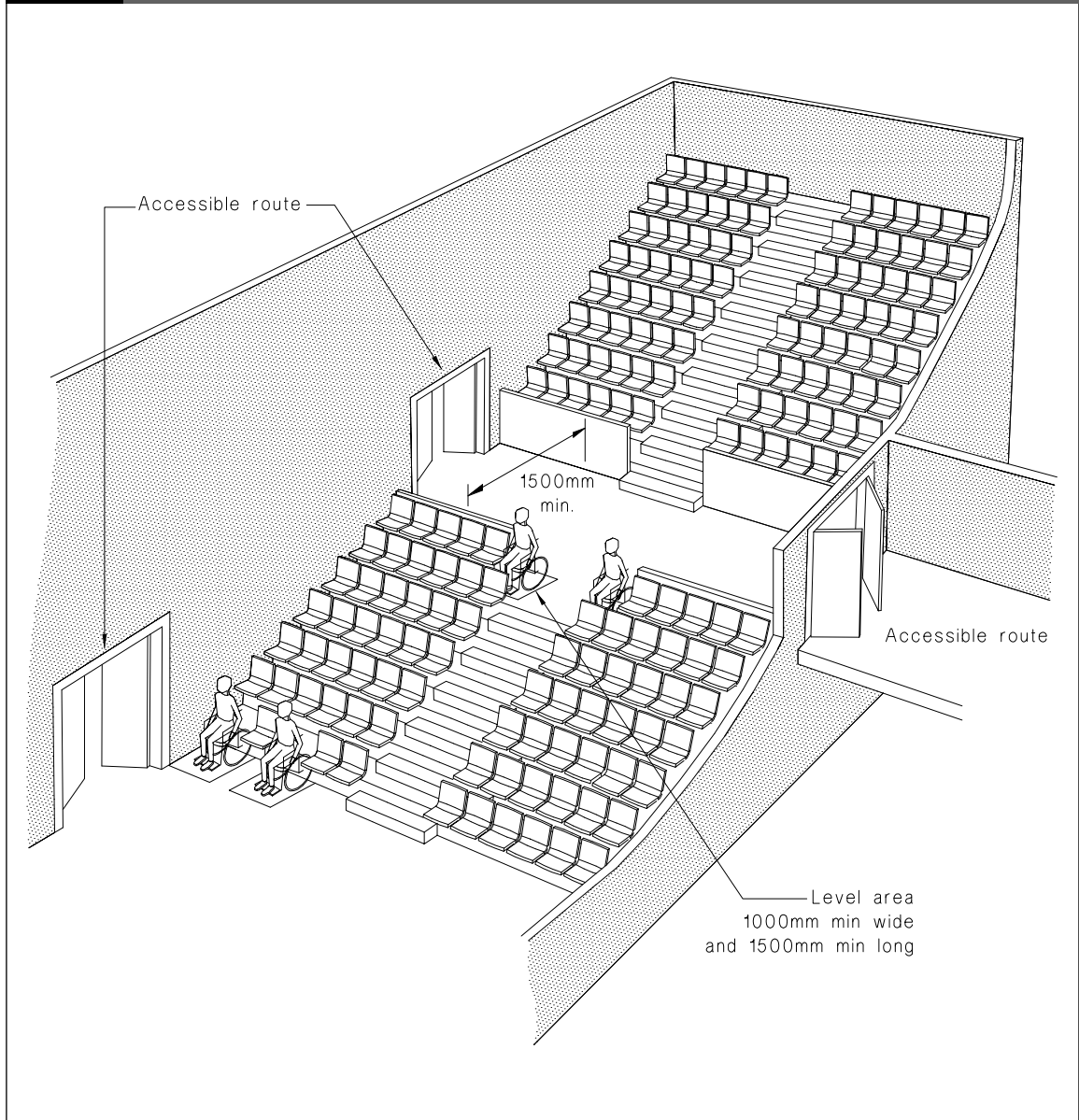

Table 9: Accessible Accommodation Units
Paragraph 9.1.1

Total number of guest units	Number of accessible units to be provided
0 – 9	1
10 – 25	2

Plus 1 unit for every additional 25 guest units provided.

9.2 Facilities to be provided

9.2.1 Accessible accommodation units shall have:

- a) Toilet and bathroom facilities complying with G1/AS1.
- b) Kitchen facilities complying with G3/AS1.
- c) Bedrooms, sitting and dining areas with sufficient floor area for a 1500 mm diameter wheelchair turning circle.

10.0 Movement of Vehicles

10.1 Car parking areas

10.1.1 AS 2890: Part 1 as modified by Paragraph 10.2 is an acceptable solution for car parking areas and circulation routes.

COMMENT:

The width of an *accessible* car park is given in AS 2890.1 Figure 2.2 as 3.2 m, but it is noted in 2.4.1 (b) (ii) of the Standard that if there is an adjacent obstruction the width of all car parks should be increased by 300 mm. In the case of an *accessible* car park an obstruction would include a kerb or garden which would prevent the movement of a wheelchair.

10.2 Modifications to AS 2890

10.2.1 AS 2890: Part 1 is modified as follows:
Clause 4.7 Lighting: After final sentence add a new sentence – “These lighting provisions may exceed the performance criteria of NZBC D1 and G8.”

Appendix C: Delete and replace with:

“*Accessible* car parking spaces shall be provided on the scale of:

- 1 for up to 10 total spaces provided
 - 2 for up to 100 total spaces provided
 - plus 1 more for every additional 50 spaces
- when car parks are provided in or associated with a *building* which is *accessible*.”

12.0 Lifts

12.0.1 For the purposes of determining whether a lift must be provided for *people with disabilities* to access upper floors, the design occupancy shall be determined using C/AS1 Paragraph 2.3.7 and Table 2.2.

Amend 4
Jul 2001

COMMENT:

Alternative design occupancies being less than derived from Table 2.2, must be justified with clear supporting information. Table 2.2 already takes account of effective floor area reductions for normal furnishings associated with a given activity, such as desks or workstations in offices. However, in a factory situation with fixed machinery, actual operator numbers may be acceptable as the *occupant load*.

Amend 4
Jul 2001

12.0.2 *Building* size may also be used to determine the need for a lift for *people with disabilities*. NZS 4121 is an acceptable solution based on gross floor area.

Amend 5
Oct 2011

11.0 Other Acceptable Solutions

11.0.1 Accessible routes – The access provisions of NZS 4121 are an acceptable solution for *accessible routes*, but may exceed the requirements of NZBC D1.

11.0.2 Commercial vehicles – AS 2890: Part 2 is an acceptable solution for loading spaces and circulation routes for commercial vehicles, but may exceed the requirements of NZBC D1.

11.0.3 Access routes for service and maintenance personnel – NZS/AS 1657 is an acceptable solution for fixed platforms, walkways, *stairways*, and ladders, but provisions may exceed the requirements of NZBC D1.

Index D1/VM1 & AS1

All references to Verification Methods and Acceptable Solutions are preceded by **VM** or **AS** respectively.

Access routes	AS1 1.1.5, 1.2.2, 1.4.1, 1.5.1, 1.5.3 a), 1.5.4, 1.5.5, 1.6.1, 1.7.1, 1.8.1, 2.0, 5.1.3, 10.1.4, Figure 27
see also Level access routes	
service and maintenance personnel	AS1 11.0.4
Accessible accommodation units	AS1 9.0, 9.1, 9.1.1, 9.2.1, Table 9
facilities	AS1 9.2
bedrooms	AS1 9.2.1 c)
dining areas	AS1 9.2.1 c)
kitchens	AS1 9.2.1 b)
sitting areas	AS1 9.2.1 c)
toilets and baths	AS1 9.2.1 a)
Accessible routes	AS1 1.1.1, 1.1.2, 1.1.3, 1.5.5 b), 2.1.1, 2.2.1, 2.3.1, 7.0.1, 7.0.6, 11.0.1, Figure 27
access to performance areas	AS1 8.2
Accessible units	AS1 1.1.3
Barriers	AS1 1.7
see also Handrails	
Buildings	AS1 1.1.1, 1.1.2, 1.1.4 10.1.4, 10.4.1,
entrances	AS1 10.1.3
Communal residential buildings	AS1 9.0, 9.1.1
Community service buildings	AS1 1.1.3
Doors	AS1 7.0, Figure 27
accessible doors	AS1 7.0.3, 7.0.4, 7.0.5
frameless glass doors	AS1 7.0.7
glazing	AS1 7.0.4, Figure 28
handles	AS1 7.0.5
lobby doors	AS1 7.0.1
revolving doors	AS1 7.0.6, Figure 29
turnstiles	AS1 7.0.6
visibility	AS1 7.0.4
width	AS1 7.0.3
Escape routes	AS1 1.1.5

Amend 5
Oct 2011

- Handrails** **AS1** 1.5.2, 1.5.4 b), 1.6.1, 1.7,
5.2.1 g), 6.0, 6.0.1, 6.0.2,
Figures 6 and 19
clearances **AS1** 6.0.7, Figure 26
handrail profiles **AS1** 6.0.7, 6.0.8, 6.0.9, Figure 26
height **AS1** 6.0.6, Figure 25
horizontal extensions **AS1** 6.0.4, 6.0.5, Figure 25
intermediate handrails **AS1** 6.0.2
relevant width **AS1** 6.0.9, Figure 26
slope **AS1** 6.0.4
- Height clearances** **AS1** 1.4, 1.4.1, Figure 3, Table 1
- Hotels** **AS1** 9.1.1
- Kerbs** **AS1** 1.5.4 a), Figure 6
see also Ramps
- Ladders** **AS1** 5.0, 5.1.1
height **AS1**, 5.1.2, 5.1.7
individual rung-type ladders **AS1** 5.1.1 c), 5.4, Figure 24
clearance **AS1** 5.4.1 c)
height **AS1** 5.4.1 c)
rungs **AS1** 5.4.1 a)
tread width **AS1** 5.4.1 b)
width **AS1** 5.4.1 b)
landings **AS1** 5.3.2
length **AS1** 5.1.5, 5.1.7
width **AS1** 5.1.4
location **AS1** 5.1.3
rung spacing **AS1** 5.1.6
rung-type ladders **AS1** 5.1.1 b), 5.3, Figure 20
clearances **AS1** 5.3.1 e)
height **AS1** 5.3.1 d)
landings **AS1** 5.3.2, Figure 23
rungs **AS1** 5.3.1 b)
slope **AS1** 5.3.1 a)
width **AS1** 5.3.1 c)
safety enclosures **AS1** 5.1.2, Figures 21, 22
step-type ladders **AS1** 5.1.1 a), 5.2, 5.2.1 a), Figure 19
clearances **AS1** 5.2.1 e)
height **AS1** 5.2.1 d)
horizontal openings **AS1** 5.2.1 f)
slope **AS1** 5.2.1 a)
treads **AS1** 5.2.1 b)
width **AS1** 5.2.1 c)
types of ladders **AS1** 5.1.1

Level access routes	AS1 2.0
protection from falling	AS1 2.3
slip resistance	AS1 2.1, Table 2
width	AS1 2.2
Lifts	AS1 12.0
Lighting	AS1 1.5.4, 1.8
Location	AS1 1.1
Motels	AS1 9.1.1
Obstructions	AS1 1.5
dangerous projections	AS1 1.5.4, Figure 6
isolated columns	AS1 1.5.5, Figure 7
major projections	AS1 1.5.3, Figure 5
minor projections	AS1 1.5.1, 1.5.2, Figure 4
Occupancy	AS1 12.0
Openings	
see Doors	AS1 7.0.1
Other Acceptable Solutions	AS2 11.0
People with disabilities	AS1 1.1.4, Table 9
Places of assembly	AS1 8.0
Principal entrance	AS1 1.1
Ramps	AS1 1.3.1, 1.3.2, 3.0
accessible ramps	AS1 3.1.3, 6.0.2, 6.0.3, 6.0.4, Figure 9
slopes	AS1 Table 3
width	AS1 3.2
intermediate landings	AS1 3.3.1, Table 5
length	AS1 3.3.3
width	AS1 3.3.2
kerb ramps	AS1 3.4, Figure 10
landings	AS1 3.3, Figure 25
service ramps	AS1 3.1.2, Figure 8, Table 4
slip resistance	AS1 3.1.4, Table 2
slopes	AS1 3.1, 3.1.1
Signs	AS1 1.1.1
Slip resistance	VM1 1.0, AS1 2.1, 3.1.4, 4.1.4 c), Table 2
Slopes	AS1 1.2
acceptable slopes	AS1 1.2.1, Figure 2
changes in level	AS1 1.3, 1.3.1
cross falls	AS1 1.2.2

Amend 5
Oct 2011

- Stairways** **AS1** 4.0
- accessible stairways **AS1** 4.1.7, 4.1.8 b), 4.2.1, 6.0.1, 6.0.2, 6.0.3, 6.0.4, Figure 11, Tables 6, 7, 8
 - common stairways **AS1** 4.1.8, 4.2.1, Figure 11, Tables 6, 7, 8
 - curved stairways **AS1** 4.1.3, 4.4, Figure 17
 - Stairways (continued)
 - landings **AS1** 4.3, 4.3.1, 4.3.6 c), 4.6.2 c), Figures 14, 25
 - direction changes **AS1** Figure 16
 - length **AS1** 4.3.4, 4.3.6 c)
 - maximum rise **AS1** 4.3.2, Table 7
 - obstructions **AS1** 4.3.5, Figure 15
 - width **AS1** 4.3.3
 - lighting **AS1** 4.5, 4.5.2, Table 8
 - pitch **AS1** 4.1, Figure 11, Table 6
 - pitch lines **AS1** 4.1.3, 4.4.1, 4.4.2, 4.5.1, 4.5.2
 - private stairways **AS1** 4.6.2, Figure 11, Tables 6, 8
 - main **AS1** Figure 11, Table 6
 - minor **AS1** 4.5.1, Figure 11, Table 6
 - secondary **AS1** 4.5.1, Figure 11, Table 6
 - risers **AS1** 4.1, 4.1.2, 4.1.3, 4.1.8, 4.4.2, 4.5.1, Figures 11, 12, Table 6
 - service stairs **AS1** 4.5.1, Figure 11, Tables 6, 8
 - slip resistance **AS1** 4.1.4 c), Table 2
 - spiral stairs **AS1** 4.1.3, 4.4.1
 - treads **AS1** 4.1, 4.1.2, 4.1.3, 4.1.4, 4.1.5, 4.1.6, 4.1.7, 4.5.1, 4.6, Figures 11, 12, 13, Table 6
 - tapered treads **AS1** 4.4, Figure 17
 - visibility **AS1** 4.3.6, 4.6, Table 8
 - width **AS1** 4.2, 4.2.1, 4.4.1, 4.5.2, 4.5.3, 6.0.1
 - winders **AS1** 4.5, Figure 18
- Structural stability** **AS1** 1.6
- Thresholds** **AS1** 1.3.2
- Turnstiles** see Doors
- Vehicles** **AS1** 10.0
- accessible car parking **AS1** 10.1, 10.2
 - car parking areas **AS1** 10.1
 - commercial vehicles **AS1** 11.0.2
 - loading spaces **AS1** 11.0.2
- Weather stops** **AS1** 1.3.2
- Wheelchairs** **AS1** 7.0.1
- spaces for wheelchairs **AS1** 8.1, 8.1.2, Figure 30