

Acceptable Solution E2/AS2

1.0 Earth buildings

Earth buildings complying with NZS 4299 as modified by this Acceptable Solution meet the performance criteria of NZBC E2.

Where *buildings* are based on NZS 4299 but require specific structural engineering design input, the structure must be of at least equivalent stiffness to the provisions of NZS 4299. Such designs are outside the scope of this Acceptable Solution and proposals must be submitted to, and approved by, the building consent authority as part of the normal building consent process.

1.1 Modifications to NZS 4299

Clause 2.1.8.5 Add new Clause:

2.1.8.5

Install a damp proof course (DPC) to separate timber from concrete, cement stabilised earth and lime stabilised earth. DPC material must be bituminous paint or sheet material as specified in Clause 4.9.1.

Figure 4.1 Replace Figure 4.1 with:

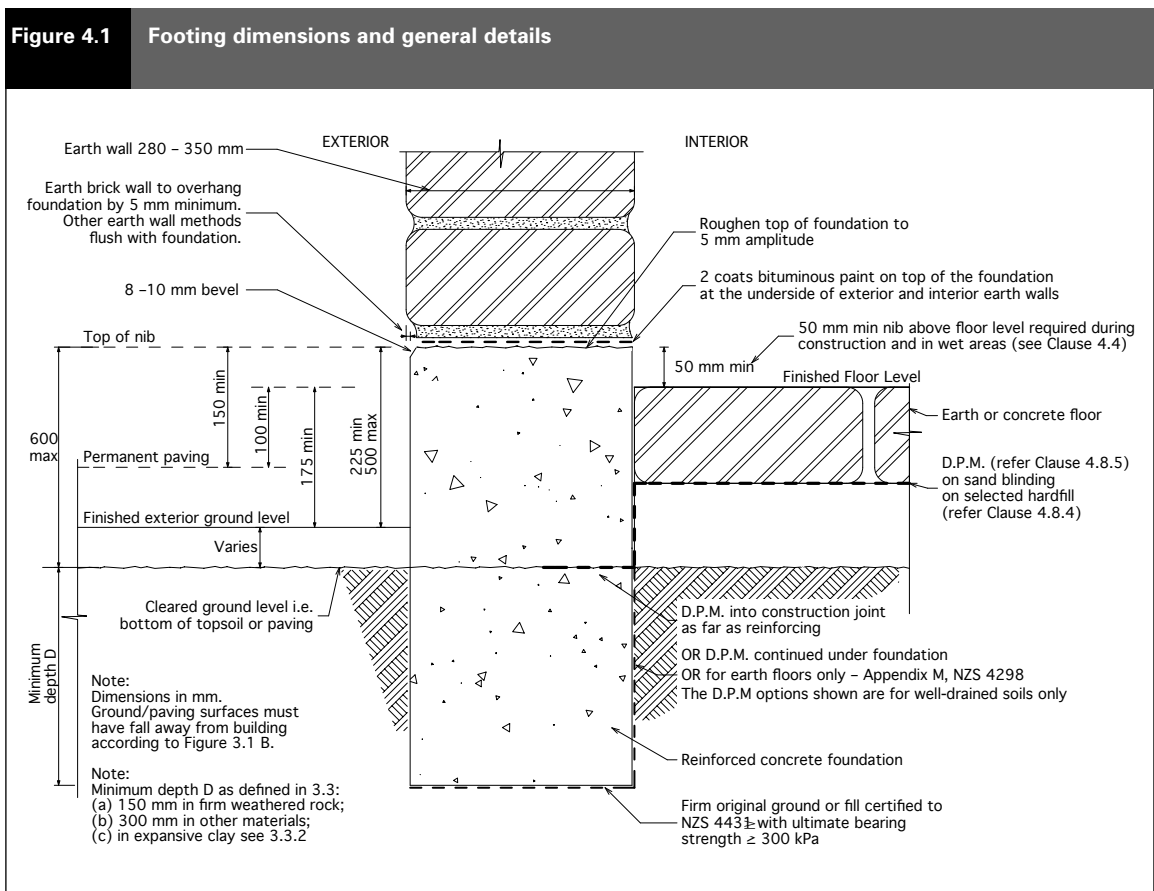

Clause 5.1.8 Add new Clause:

5.1.8

The external surface of earth walls must be finished in accordance with Clauses 2.2.3.5, 2.2.4.2 and 2.2.4.3 of NZS 4298. The external surface of earth walls must be free from features, such as horizontal protrusions, that could cause water to become trapped or directed towards the inside of the building.

C5.1.8

Water must be able to flow downwards and off the external surface of earth walls.

External earth wall surfaces are not required to have a surface coating to meet this Acceptable Solution.

The use of surface coatings does not replace or diminish the need for eaves as required by Clause 2.10.

Clause 5.1.12 Add new Clause and Figure:

5.1.12 Soffit to wall junction

The junction between the soffit and the earth wall must be constructed as shown in Figure 5.11.

Figure 5.11 Soffit to wall junction
A) Flat soffit

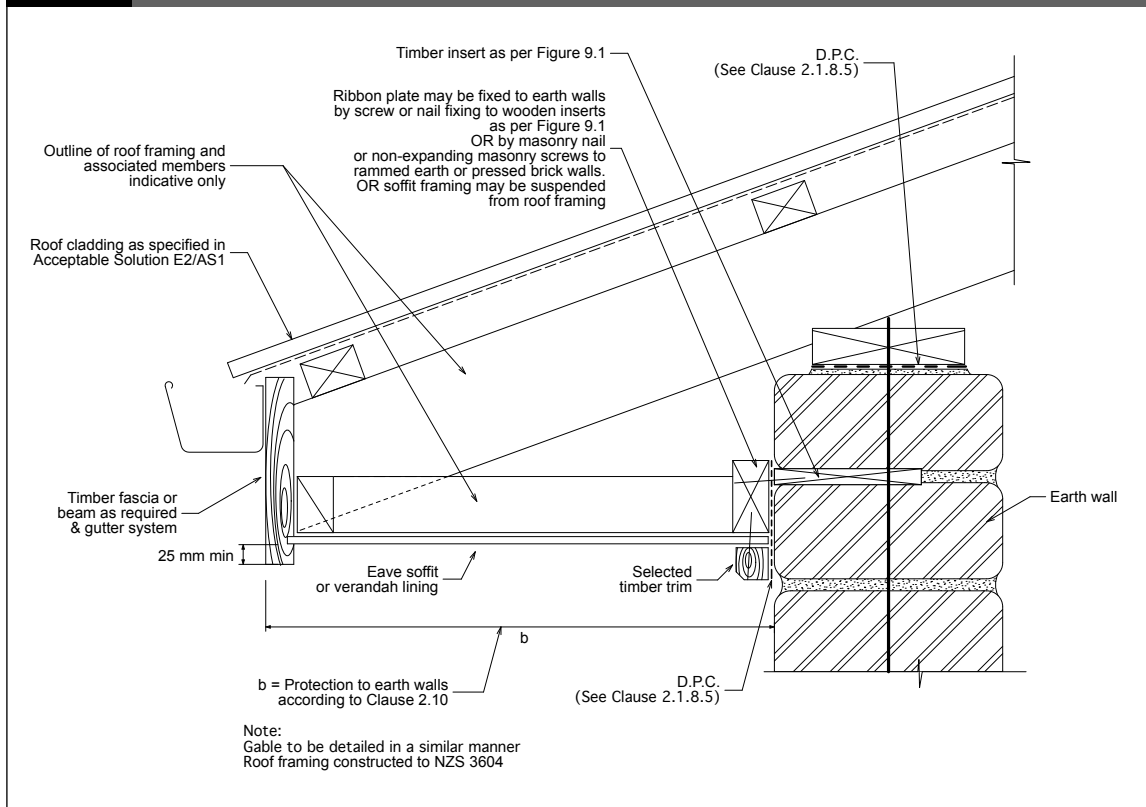

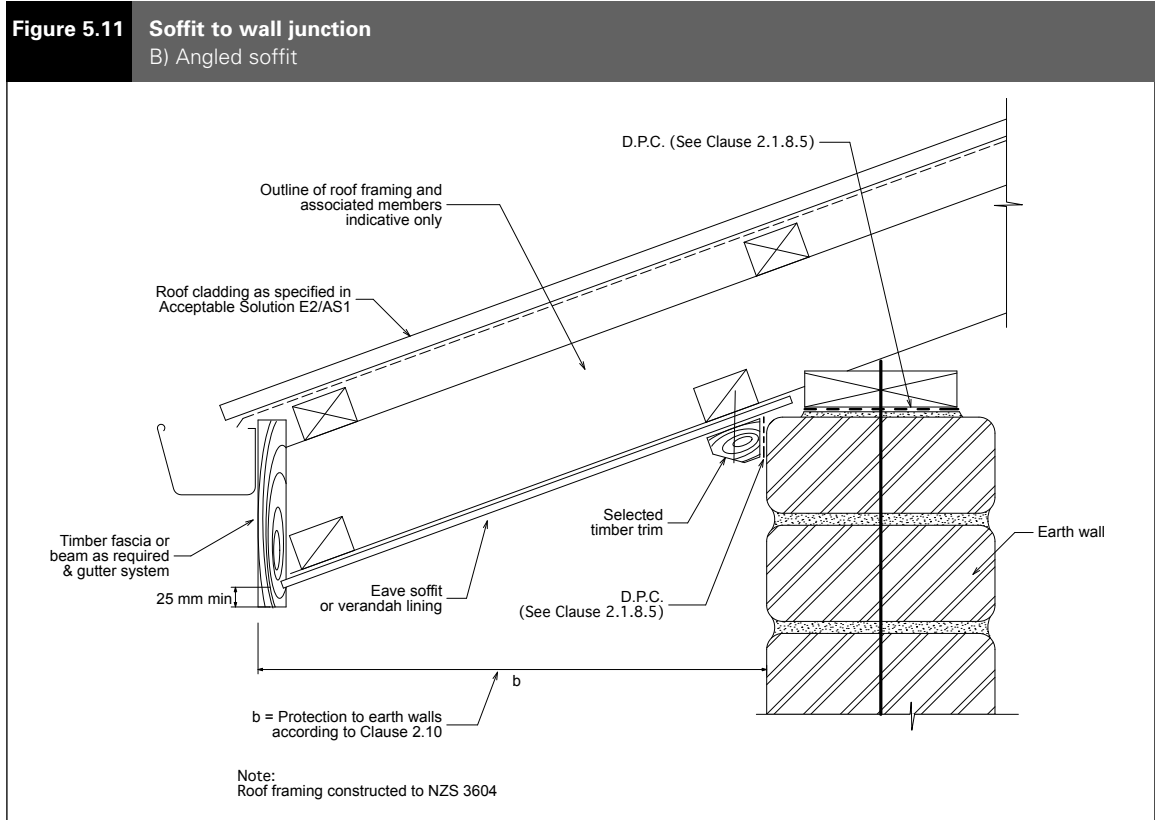

Clause 5.13 Add new Clause and Figure:

5.13 Timber-framed gable wall

The junction between timber-framed gable walls and earth walls must be constructed as shown in Figure 5.12.

Figure 5.12 Timber-framed gable to earth wall

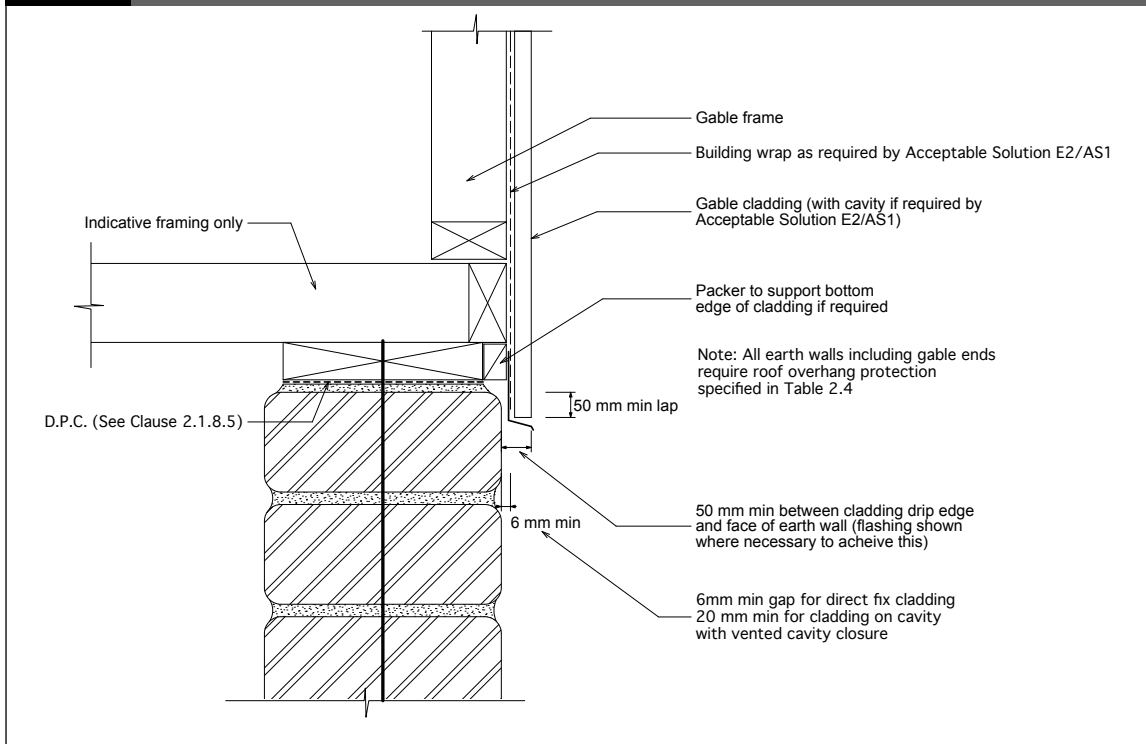

Clause 9.2 Add the following new paragraph to end of Clause 9.2:

“Windows and doors with arched or sloping heads are outside the scope of this Standard”.

Clause C9.2 Add the following new paragraph to end of commentary Clause C9.2:

Amend 5
Aug 2011

COMMENT:

Requirements for window and door joinery are not included in this Acceptable Solution. For more information, designers may refer to:

- NZS 3504: 1979 *Specification for aluminium windows*
- NZS 3610: 1979 *Specification for profiles of mouldings and joinery*
- NZS 3619: 1979 *Specification for timber windows.*

Figure 9.2 Replace Figure 9.2 with:

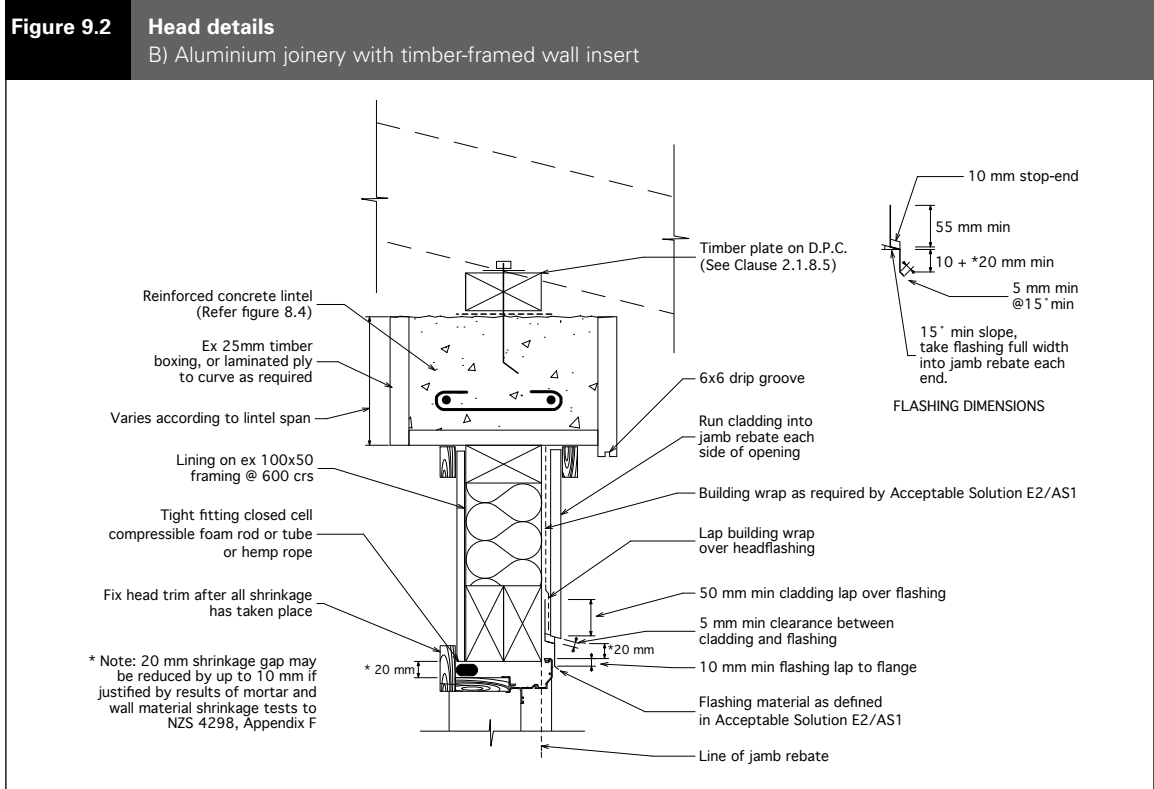
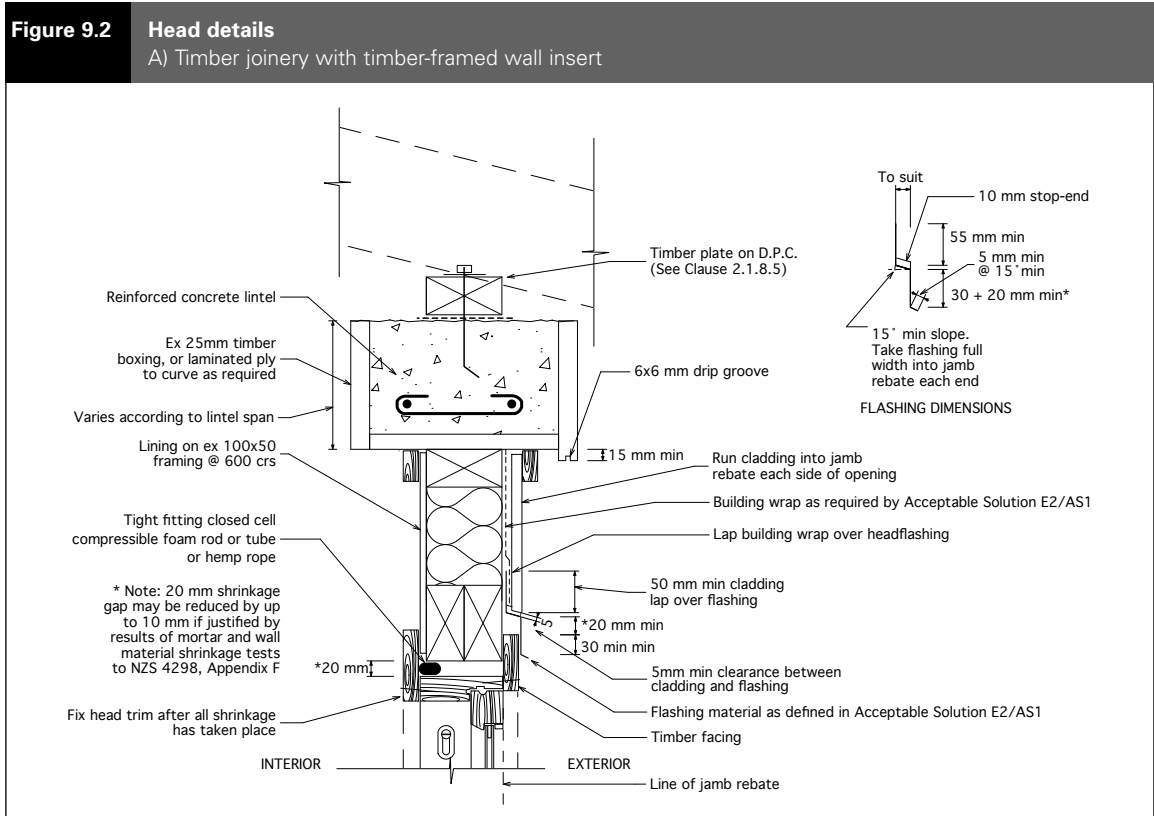

Figure 9.2 Head details
C) Timber joinery with timber lintel

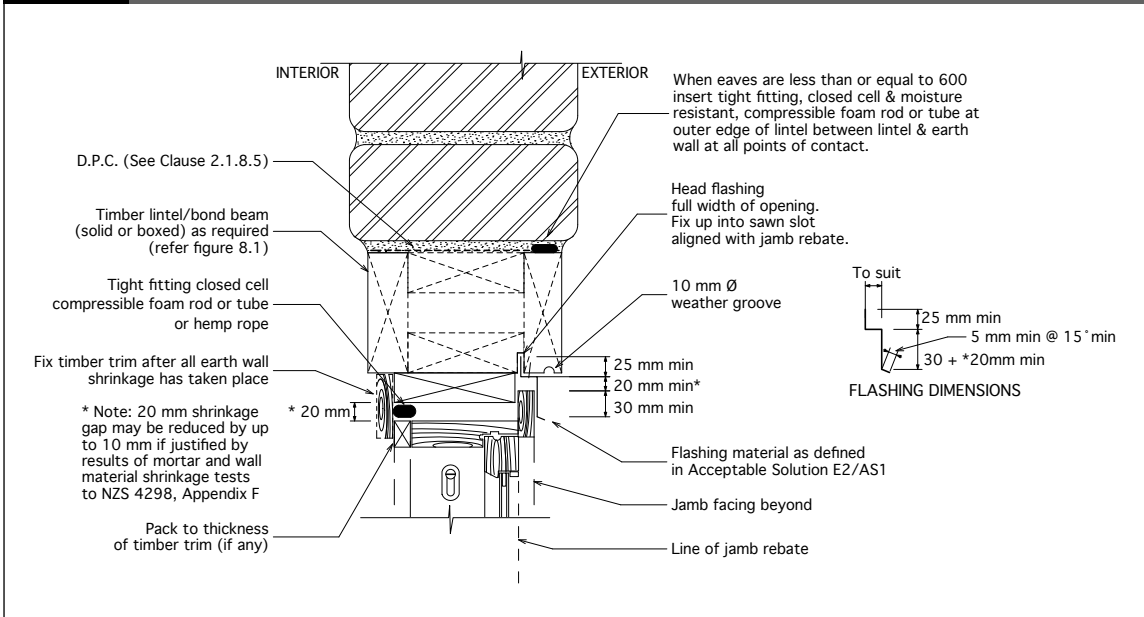

Figure 9.2 Head details
D) Aluminium joinery with timber lintel

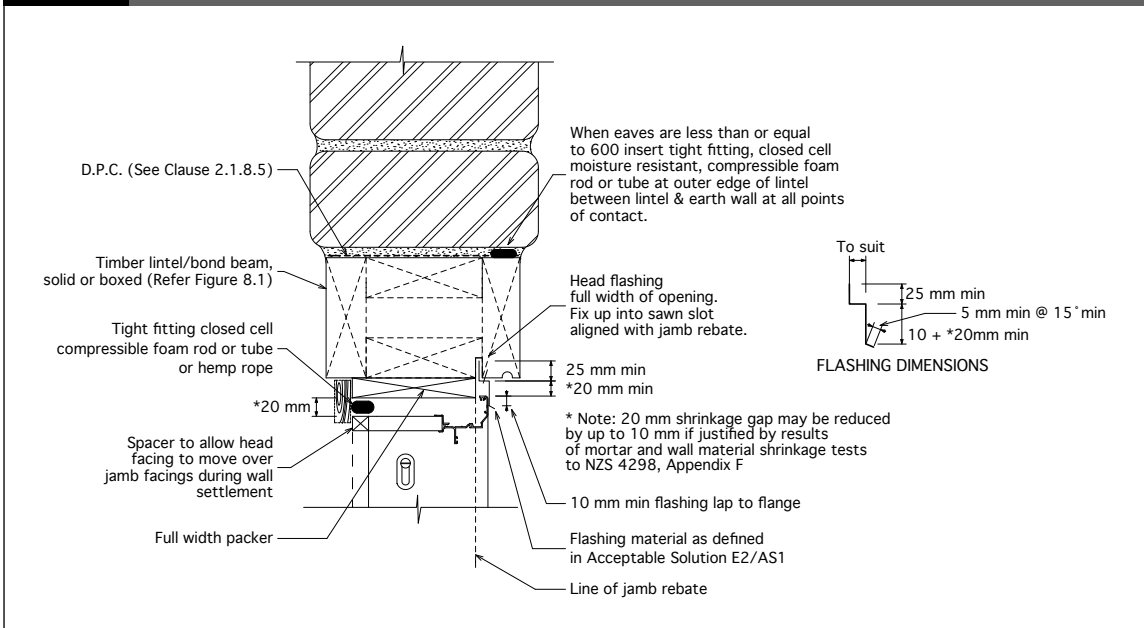

Figure 9.3 Replace Figure 9.3 with:

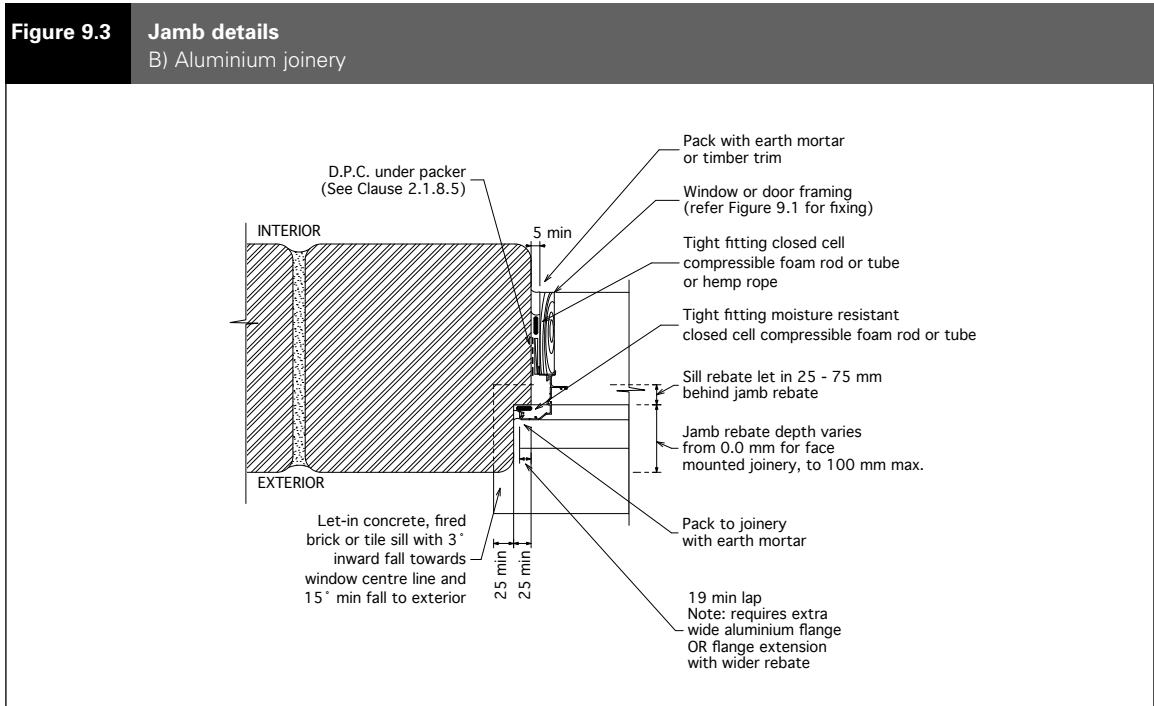
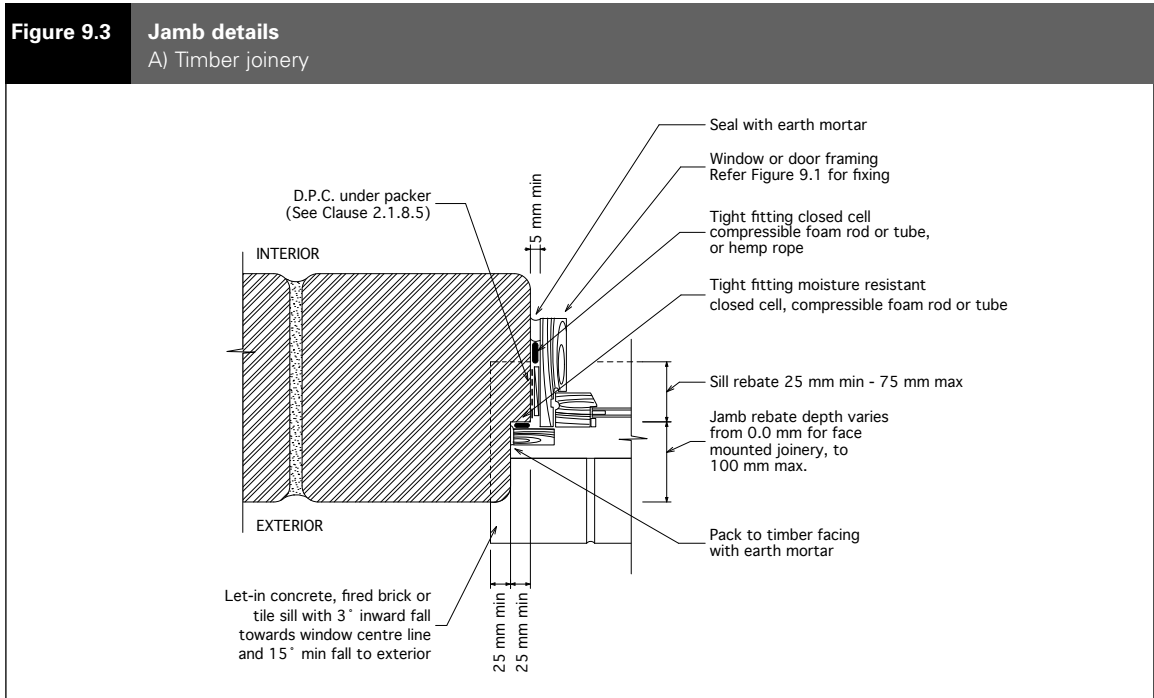

Figure 9.4 Replace Figure 9.4 with:

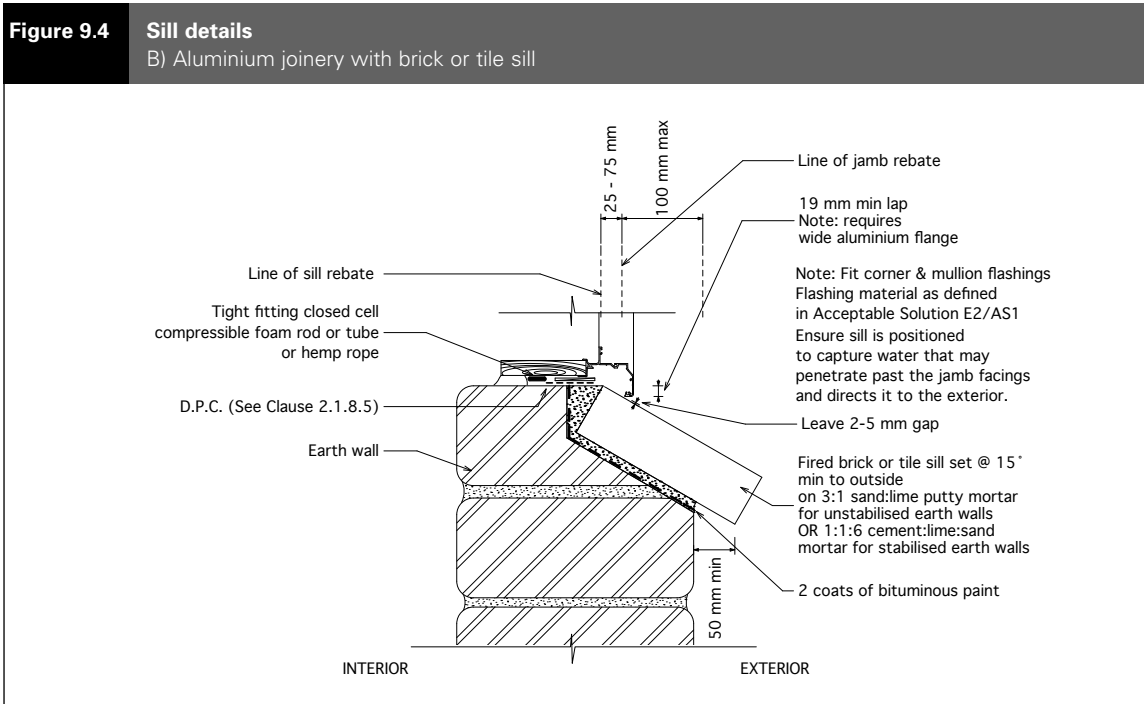
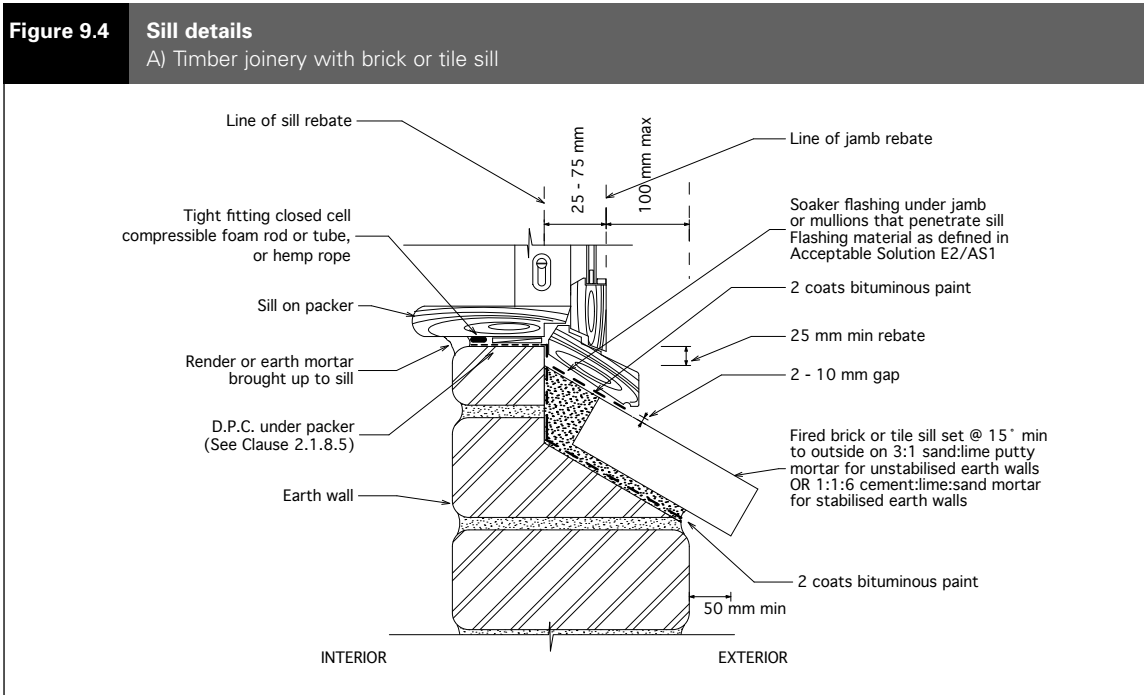

Figure 9.4 Sill details
C) Timber joinery with concrete sill

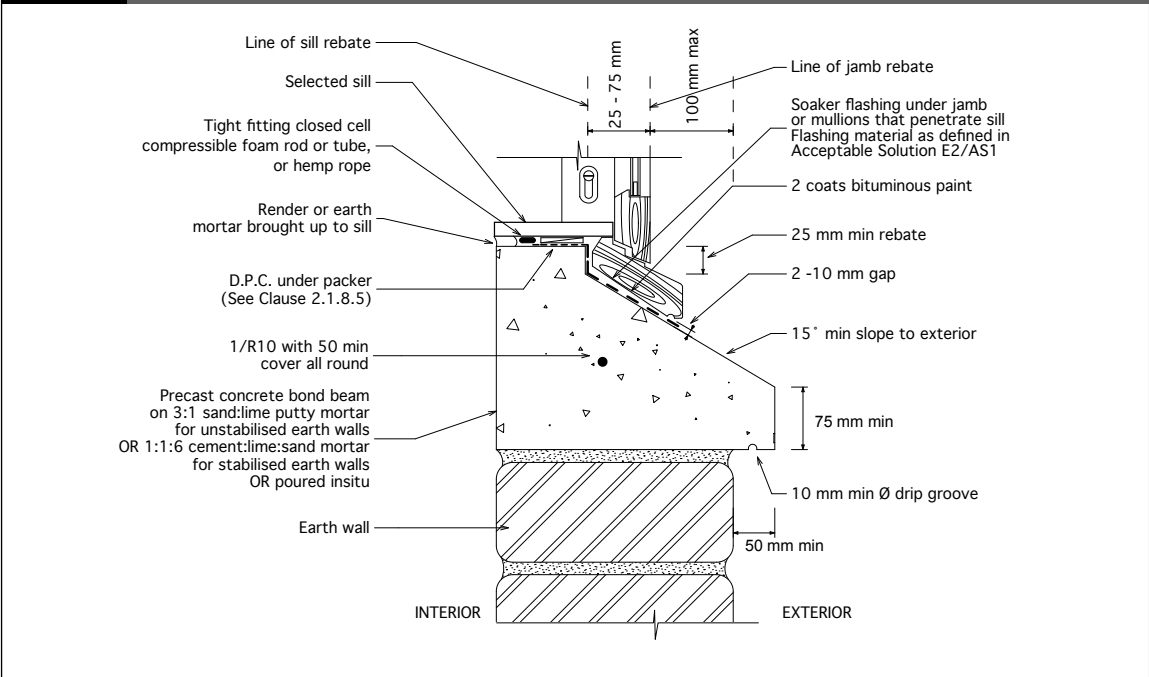
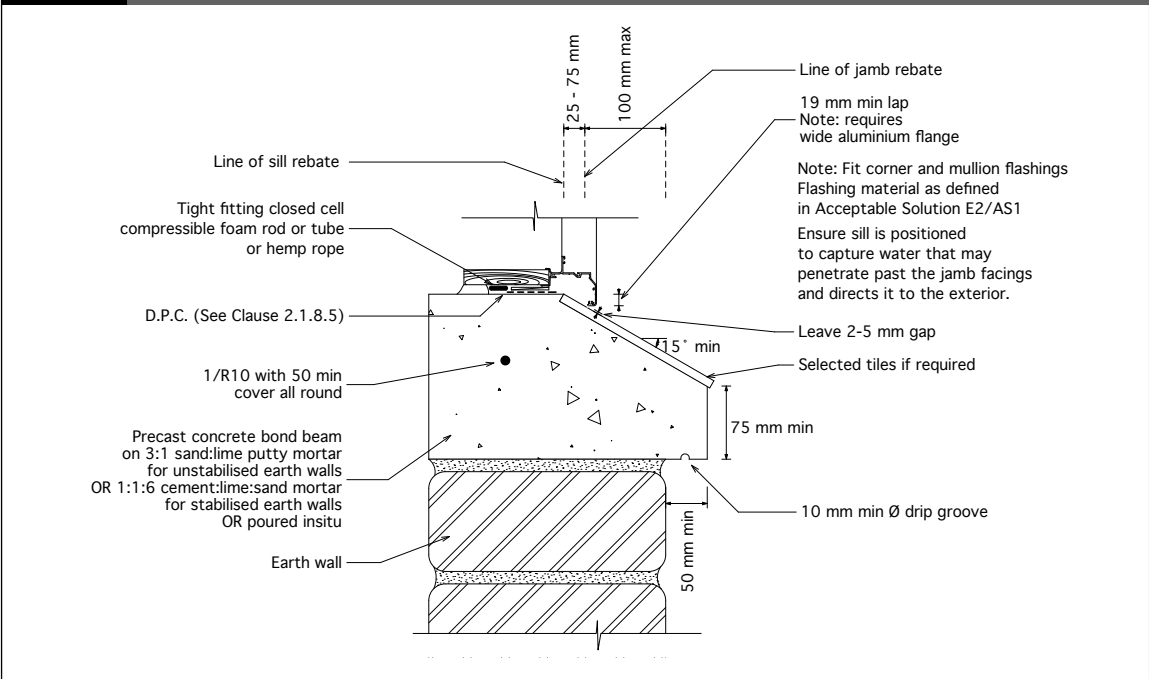

Figure 9.4 Sill details
D) Aluminium joinery with concrete sill



Clause 9.7 Add new Clause:

9.7 Penetrations

9.7.1

The upper surface of elements (e.g. pipes and meterboxes) that penetrate external walls must be sloped downwards to the exterior to direct moisture away from the wall and to discharge it clear of the wall surface.

COMMENT:

C9.7.1

Penetrations should be located where they are sheltered from wind-driven rain – this may be achieved by positioning the penetration in a sheltered location or as high as practical under eaves on the wall.

9.7.2

Penetrations less than 200mm wide must meet the requirements of NZS 4298 Clause 2.1.12 and must be sealed all round with a tight-fitting moisture resistant compressible closed cell foam rod or tube that is finished 25 mm behind the wall surface, with the resulting gap filled with:

- i) for unstabilised earth construction, a compatible unstabilised mortar
- ii) for stabilised earth construction, a compatible stabilised mortar.

COMMENT:

C9.7.2

Generally sealants do not adhere well to earthen surfaces with the possible exception of dense stabilised rammed earth or pressed earth brick.

9.7.3

Penetrations more than 200mm wide (e.g. meterboxes) must be anchored as required in Clause 9.1 and must meet the following requirements:

- a) Where the depth of the penetration is more than 1/3 of the wall depth, the penetration must incorporate head, jamb and sill details similar to those required for windows.
- b) Where the depth of the penetration is less than 1/3 of the wall depth, the penetration must be sealed all round with a compatible mortar as required by Clause 9.7.2.

Amend 5
Aug 2011

Amend 5
Aug 2011

Acceptable Solution E2/AS3

1.0 Concrete and Concrete Masonry Buildings

Concrete and concrete masonry construction with the scope of CCANZ CP 01, and that complies with CCANZ CP 01, will meet the performance criteria of NZBC E2.

Errata 2
Dec 2011
Amend 5
Aug 2011

Index E2/VM1 & AS1/AS2/AS3

**Pages 193–204 INDEX deleted
by Amendment 5**

