



Department of  
Building and Housing  
*Te Tari Kaupapa Whare*

Dear Customer

Please find enclosed Amendment 4, effective 10 October 2011, to the Compliance Document for Clause G13 Foul Water of the New Zealand Building Code.

<b>Section</b>	<b>Old G13</b>	<b>October 2011 Amendments to G13</b>
Title pages	Remove title page and document history	Replace with new title page and document history
References	Remove page 7/8	Replace with new page 7/8
Definitions	Remove page 9/10	Replace with new page 9/10
G13/AS2	Remove page 37/38	Replace with new page 37/38



# Compliance Document for New Zealand Building Code Clause G13 Foul Water – Second Edition

Prepared by the Department of Building and Housing

This Compliance Document is prepared by the Department of Building and Housing. The Department of Building and Housing is a Government Department established under the State Sector Act 1988.

Enquiries about the content of this document should be directed to:



Department of  
Building and Housing  
*Te Tari Kaupapa Whare*

Department of Building and Housing  
PO Box 10-729, Wellington.  
Telephone 0800 242 243  
Fax 04 494 0290  
Email: [info@dbh.govt.nz](mailto:info@dbh.govt.nz)

**Compliance Documents are available from [www.dbh.govt.nz](http://www.dbh.govt.nz)**

## New Zealand Government

© Department of Building and Housing 2011

This Compliance Document is protected by Crown copyright, unless indicated otherwise. The Department of Building and Housing administers the copyright in this document. You may use and reproduce this document for your personal use or for the purposes of your business provided you reproduce the document accurately and not in an inappropriate or misleading context. You may not distribute this document to others or reproduce it for sale or profit.

The Department of Building and Housing owns or has licences to use all images and trademarks in this document. You must not use or reproduce images and trademarks featured in this document for any purpose (except as part of an accurate reproduction of this document) unless you first obtain the written permission of the Department of Building and Housing.

## Status of Compliance Documents

Compliance Documents are prepared by the Department of Building and Housing in accordance with section 22 of the Building Act 2004. A Compliance Document is for use in establishing compliance with the New Zealand Building Code.

A person who complies with a Compliance Document will be treated as having complied with the provisions of the Building Code to which the Compliance Document relates. However, a Compliance Document is only one method of complying with the Building Code. There may be alternative ways to comply.

Users should make themselves familiar with the preface to the New Zealand Building Code Handbook, which describes the status of Compliance Documents and explains alternative methods of achieving compliance.

Defined words (italicised in the text) and classified uses are explained in Clauses A1 and A2 of the Building Code and in the Definitions at the start of this Compliance Document.

<b>G13: Document History</b>			
	<b>Date</b>	<b>Alterations</b>	
First published	July 1992		
Amendment 1	September 1993	pp. vii–viii, References p. xi, Definitions	p.25, Figure 3 p. 31, Figure 7
Reprinted incorporating Amendment 1	October 1994		
Amendment 2	1 December 1995	p. viii, References	
Amendment 3	28 February 1998	p. ii, Document History p. viii, References	p. 1, 1.0.1 p. 21, 1.0.1
Second edition published 1 July 2001	Effective from 1 October 2001	Document revised – second edition issued	
Amendment 1	Published March 2007 Effective from 23 June 2007	p. 2, Document History, Status p. 6, Contents pp. 7–8, References	pp. 9–10, Definitions p. 52A, AS3 1.0, 1.0.1, 1.0.2 p. 55, Index
Erratum 1	Effective from 23 June 2007	pp. 5–6, Contents pp. 33–34, AS1 8.0, 8.1 pp. 50–51, AS2 7.0, 7.1	
Amendment 2	Effective from 21 June 2007	p. 2, Document History, Status pp. 3, 4, 4A, Building Code Clause p. 6, Contents	p. 8, References p. 52A, VM4 p. 54, Index
Amendment 3	Published 30 June 2010 Effective from 30 September 2010	p. 2, Document History, Status pp. 7–8, References p. 11, G13/VM1 1.0.1 p. 13, G13/AS1 Table 1 p. 32, G13/AS1 6.1.1 p. 33, G13/AS1 6.2.2, 6.3.1, 6.3.2, 7.1.2, Table 7	p. 37, G13/AS2 Table 1 p. 42, G13/AS2 5.1.2 p. 50, G13/AS2 6.1.2 p. 51, G13/AS3 1.0.1 pp. 54–55, Index
Amendment 4	10 October 2011	p. 2, Document History, Status p. 8, References p. 10, Definitions	p. 37, G13/AS2 Table 1
<b>Note: Page numbers relate to the document at the time of Amendment and may not match page numbers in current document.</b>			

### Document Status

The most recent version of this document, as detailed in the Document History, is approved by the Chief Executive of the Department of Building and Housing. It is effective from 10 October 2011 and supersedes all previous versions of this document.

People using this Compliance Document should check for amendments on a regular basis. The Department of Building and Housing may amend any part of any Compliance Document at any time. Up-to-date versions of Compliance Documents are available from [www.dbh.govt.nz](http://www.dbh.govt.nz)

# References

For the purposes of New Zealand Building Code (NZBC) compliance, the Standards and documents referenced in this Compliance Document (primary reference documents) must be the editions, along with their specific amendments, listed below. Where these primary reference documents refer to other Standards or documents (secondary reference documents), which in turn may also refer to other Standards or documents, and so on (lower-order reference documents), then the version in effect at the date of publication of this Compliance Document must be used.

Amend 4  
Oct 2011

Amend 3  
Sep 2010

Amend 3  
Sep 2010

Amend 3  
Sep 2010

Amend 3  
Sep 2010

Amend 3  
Sep 2010

Amend 3  
Sep 2010

Amend 3  
Sep 2010

Amend 4  
Oct 2011

## Standards New Zealand

		Where quoted
NZS 3501: 1976	Specification for copper tubes for water, gas, and sanitation <i>Amends: 1, 2, 3</i>	AS1 Table 1, AS2 Table 1
NZS 3604: 1999	Timber framed buildings <i>Amend: 1</i>	AS2 5.6.1
NZS 4229: 1999	Concrete masonry buildings not requiring specific engineering design <i>Amend: 1</i>	AS2 5.6.1
NZS 4442: 1988	Welded steel pipes and fittings for water, sewage and medium pressure gas	AS2 Table 1

## British Standards Institution

BS 437: 2008	Specification for cast iron drain pipes, fittings and their joints for socketed and socketless systems	AS2 Table 1
BS EN 12056-2:2000	Gravity drainage systems inside buildings. Sanitary pipework, layout and calculation	VM1 1.0.1

## Standards Australia

AS 1579: 2001	Arc welded steel pipes and fittings for water and waste water	AS2 Table 1
AS 1589: 2001	Copper and copper alloy waste fittings	AS1 Table 1
AS 1646: 2007	Elastomeric seals for waterworks purposes	AS2 Table 1
AS 2887: 1993	Plastic waste fittings	AS1 Table 1
AS 3571: 2009	Plastic piping systems – Glass reinforced thermoplastics (GRP) systems based on unsaturated polyester (UP) resin – pressure and non-pressure drainage and sewerage (ISO 10467: 2004 MOD)	AS2 Table 1

		Where quoted
Amend 3 Sep 2010	AS 4139: 2003 Fibre reinforced concrete pipes and fittings	AS2 Table 1
	<b>Australian/New Zealand Standards</b>	
Amends 3 and 4	AS/NZS 1260: 2009 PVC-U pipes and fittings for drain, waste and vent applications	AS1 Table 1, AS2 Table 1
Amend 2 Jun 2007	AS/NZS 1547: 2000 On-site domestic wastewater management	VM4 1.1.2
	AS/NZS 2032: 2006 Installation of PVC pipe systems <i>Amend: 1</i>	AS1 6.1.1, 6.2.2, 6.3.1, 7.1.2 AS2 5.1.2, 6.1.2, 7.0.1, Table 1 AS3 1.0.1
Amend 3 Sep 2010		
	AS/NZS 2033: 2008 Installation of polyethylene pipe systems <i>Amend: 1, 2</i>	AS1 Table 1
Amend 4 Oct 2011	AS/NZS 2280: 2004 Ductile iron pressure pipes and fittings <i>Amend: 1</i>	AS2 Table 1
Amend 4 Oct 2011	AS/NZS 2566.2: 2002 Buried flexible pipelines installation	AS2 Table 1
Amend 1 Jun 2007	AS/NZS 3500:- Plumbing and drainage Part 2: 2003 Sanitary plumbing and drainage <i>Amend: 1</i>	AS1 7.1.3, 8.0.1, 8.0.2, 8.1, VM2 1.0.1 Comment, AS2 6.1.3, 7.0.2, 7.1 AS3 1.0.2
	AS/NZS 3518:2004 Acrylonitrile butadiene styrene (ABS) compounds, pipes and fittings for pressure applications <i>Amend: 1</i>	AS2 Table 1
	AS/NZS 4058: 2007 Pre cast concrete pipes (pressure and non pressure)	AS2 Table 1
	AS/NZS 4130: 2009 Polyethylene (PE) pipe for pressure applications <i>Amend: 1</i>	AS2 Table 1
Amend 3 Sep 2010	AS/NZS 4401: High density polyethylene (PE-HD) pipes and fittings for soil and waste discharge (low and high temperature) systems inside buildings 2006	AS1 Table 1
Amend 3 Sep 2010	AS/NZS 4936: 2002 Air Admittance valves for use in sanitary plumbing and drainage systems.	AS1 Table 1
Amend 4 Oct 2011	AS/NZS 5065: 2005 Polyethylene and polypropylene pipe and fittings for drainage and sewerage applications <i>Amend: 1</i>	AS2 Table 1
	<b>European Standards</b>	
	EN 12380: 1999 Air admittance valves for drainage systems – Requirements and test methods	AS1 5.8.2, Table 1
	<b>American Society of Sanitary Engineers</b>	
	ASSE 1050: 1991 Performance requirements for air admittance valves 1for plumbing DWV systems stack type devices	AS1 5.8.2, Table
	ASSE 1051: 1992 Performance requirements for air admittance valves for plumbing drainage systems	AS1 5.8.2, Table 1

Amend 1  
Jun 2007

# Definitions

Amend 1  
Jun 2007

This is an abbreviated list of definitions for the words or terms particularly relevant to this Compliance Document. The definitions for any other italicised words may be found in the New Zealand Building Code Handbook.

**Access chamber** A chamber with working space at *drain* level through which the *drain* passes either as an open channel or as a pipe incorporating an *inspection point*.

**Access point** A place where access may be made to a *drain* or *discharge pipe* for inspection, cleaning or maintenance; and may include a *cleaning eye*, *inspection point*, *rodding point*, *inspection chamber* or *access chamber*.

**Adequate** *Adequate* to achieve the objectives of the *building code*.

**Air admittance valve** A valve that allows air to enter but not to escape in order to limit pressure fluctuations within the sanitary plumbing or drainage system.

**Branch discharge pipe** A *discharge pipe* that serves one or more *fixture discharge pipes* for any one floor.

**Branch vent pipe** A *vent pipe* that serves two or more *fixture vent pipes*.

Amend 1  
Jun 2007

**Building** has the meaning ascribed to it by Sections 8 and 9 of the Building Act 2004.

**Cleaning eye** A small *diameter access point* usually formed as part of a fitting or trap.

**Combined waste pipe** A *discharge pipe* which serves two or more *waste pipes*.

**Developed length** The total length along the centre line of a pipe including fittings and bends.

**Diameter (or bore)** The nominal internal *diameter*.

**Discharge pipe** Any pipe that is intended to convey discharge from *sanitary fixtures* or *sanitary appliances*.

**Discharge stack** A *discharge pipe* that has one or more *discharge pipe* connections, and which is vented at one end via a *discharge stack vent*.

**Discharge stack vent** A *vent pipe* connected to the top of the *discharge stack*.

**Discharge unit** The unit of measure for the discharge (hydraulic load) in the *plumbing system*, and is based on the rate, duration and frequency of discharge from a *sanitary fixture* or *sanitary appliance*.

**Drain** A pipe normally laid below ground level including fittings and equipment and intended to convey *foul water* or *surface water* to an *outfall*.

**Drain vent pipe** Any pipe which is intended to permit the movement of air into and out of the *drain* and *sewer*.

**Fixture** An article intended to remain permanently attached to and form part of a *building*.

**Fixture discharge pipe** A *discharge pipe* that is used to convey waste from a single *sanitary fixture* or *sanitary appliance* to a *branch discharge pipe*, a *discharge stack*, or directly to a *drain*. It does not include any pipes forming part of a *sanitary appliance*.

**Fixture vent pipe (trap vent)** A *vent pipe* that is connected to a *fixture discharge pipe* or the *sanitary fixture* itself.

**Floor waste** An outlet located at the low point of a graded floor or in a level floor designed to receive accidental or intentional discharges.

**Floor waste pipe** A pipe that receives the discharge from a *floor waste* and that discharges outside the *building* or to the *foul water* drainage or sanitary *plumbing system*.

**Foul water** The discharge from any *sanitary fixture* or *sanitary appliance*.

**Foul water drainage system** *Drains*, joints and fittings normally laid underground and used specifically for the conveyance of water from the *plumbing system* to an *outfall*.

**Grease trap** A device designed to intercept grease in a *foul water* discharge.

**Gully trap** A fitting designed to prevent foul air escaping from the drainage system and used to receive the discharge from *waste pipes*.

**Inspection chamber** A chamber with working space at ground level through which the *drain* passes either as an open channel or as a pipe incorporating an *inspection point*.

**Inspection point** A removable cap at *drain* level through which access may be made for cleaning and inspecting the drainage system.

**Network utility operator** means a person who—

- a) undertakes or proposes to undertake the distribution or transmission by pipeline of natural or manufactured gas, petroleum, biofuel, or geothermal energy; or
- b) operates or proposes to operate a network for the purpose of—
  - i) telecommunication as defined in section 5 of the Telecommunications Act 2001; or
  - ii) radiocommunications as defined in section 2(1) of the Radiocommunications Act 1989; or
- c) is an electricity operator or electricity distributor as defined in section 2 of the Electricity Act 1992 for the purpose of line function services as defined in that section; or
- d) undertakes or proposes to undertake the distribution of water for supply (including irrigation); or
- e) undertakes or proposes to undertake a drainage or sewerage system.

**Outfall** That part of the disposal system receiving *surface water* or *foul water* from the drainage system. For *foul water*, the *outfall* may include a *sewer* or a septic tank. For *surface water*, the *outfall* may include a natural water course, kerb and channel, or soakage system.

**Plumbing system** Pipes, joints and fittings, laid above ground and used for the conveyance of *foul water* to the *foul water drain* and includes *vent pipes*.

**Relief vent** A *vent pipe* which is connected to a *discharge stack* below the lowest branch connection and which connects at its upper end to the *discharge stack vent* or terminates as an open vent.

**Rodding point** A removable cap at ground level through which access may be made for cleaning and inspecting the drainage system.

**Sanitary appliance** An appliance which is intended to be used for *sanitation* and which is not a *sanitary fixture*. Included are machines for washing dishes and clothes.

**Sanitary fixture** Any *fixture* which is intended to be used for *sanitation*.

**Sanitation** The term used to describe the activities of washing and/or excretion carried out in a manner or condition, such that the effect on health is minimised, with regard to dirt, contamination and infection.

**Sewer** A *drain* that is under the control of, or maintained by, a *network utility operator*.

**Soil fixture** A *sanitary fixture* constructed to receive solid and/or liquid excreted human waste. It includes bedpan disposal units, slop sinks, urinals, water closet pans, and water-flushed sanitary towel disposal units.

**Surface water** All naturally occurring water, other than sub-surface water, which results from rainfall on the site or water flowing onto the site, including that flowing from a **drain**, stream, river, lake or sea.

**Vent pipe** A pipe for the purpose of protecting *water seals* that at its upper end is either open to the atmosphere or fitted with an *air admittance valve* and that at its lower end is connected to a *discharge pipe*.

**Waste pipe** A *discharge pipe* that conveys the discharge from *waste water fixtures* to a *gully trap*.

**Waste water fixture** A *sanitary fixture* or *sanitary appliance* used to receive wastes, and which is not a *soil fixture*.

**Water seal** The depth of water that can be retained in a *water trap*.

**Water trap** A fitting designed to retain a depth of water that prevents foul air and gases escaping from the *plumbing system* or *foul water drainage system* and entering a *building*.

# Acceptable Solution G13/AS2

## Drainage

### 1.0 Scope

**1.0.1** This Acceptable Solution is for below ground non-pressure (gravity flow) *foul water drains* having a *diameter* of no greater than 150 mm.

**1.0.2** It does not apply to *foul water drainage systems* where it is necessary to dispose of industrial liquid wastes, chemical or toxic wastes and other wastes which cannot be discharged to a *sewer* without pre-treatment. See G14/MM1.

### 2.0 Materials

**2.0.1** Materials for drainage pipes and joints shall comply with the appropriate standards shown in Table 1.

#### 2.1 Fill materials

**2.1.1** Fill materials, as shown in Figure 7, shall be:

- a) Bedding material of clean granular non-cohesive material with a maximum particle size of 20 mm,

- b) Selected fill of fine-grained soil or granular material that is free from topsoil and rubbish and has a maximum particle size of 20 mm, or
- c) Ordinary fill of excavated material.

### 3.0 Design

#### 3.1 Bends

**3.1.1** To reduce the risk of blockages, the *foul water drainage system* shall:

- a) Have a simple layout that incorporates the least number of changes of direction,
- b) Use bends having a radius of the practical maximum, and
- c) Be laid only in straight lines between bends or junctions (both horizontally and vertically).

#### 3.2 Junctions

**3.2.1** Any connection to a *drain*, excluding *vent pipe* connections, shall be made by means of sweep or oblique junctions. The angle that the branch makes at the point of entry with the main *drain*, shall be no greater than 60° (see Figure 1).

**Table 1: Materials for drainage pipes**  
Paragraphs 2.0.1 and 5.3.1

	Material	Manufacturing Standard	Installation Standard
Amend 3 Sep 2010	Cast iron	BS 437	
	Concrete	AS/NZS 4058	
	Steel	NZS 4442 or AS 1579	
Amend 3 Sep 2010	PVC-U	AS/NZS 1260	AS/NZS 2032
Amend 4 Oct 2011	Polyethylene	AS/NZS 4130, AS/NZS 2065	AS/NZS 2033
	Polypropylene	AS/NZS 2065	AS/NZS 2566
Amend 3 Sep 2010	Ductile iron	AS/NZS 2065	
	ABS	AS/NZS 3518	
	Copper	NZS 3501	
	GRP	AS 3571	
	FRC	AS 4139	
Amend 3 Sep 2010	Elastomeric rings	NZS/BS 2494 or AS 1646	

**Figure 1:** Connection of drains  
Paragraph 3.2.1

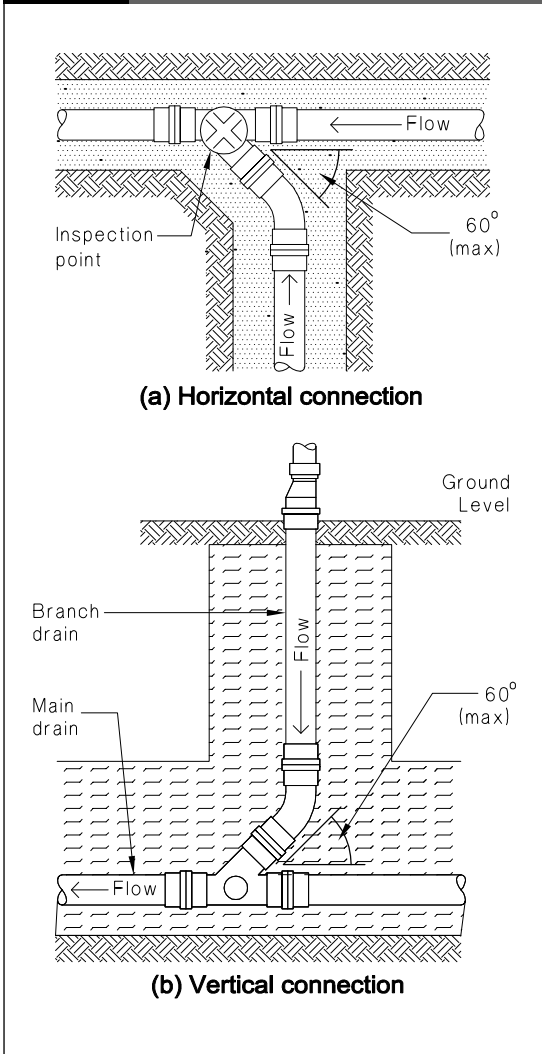

**Figure 2:** Details of gully traps  
Paragraph 3.3.1

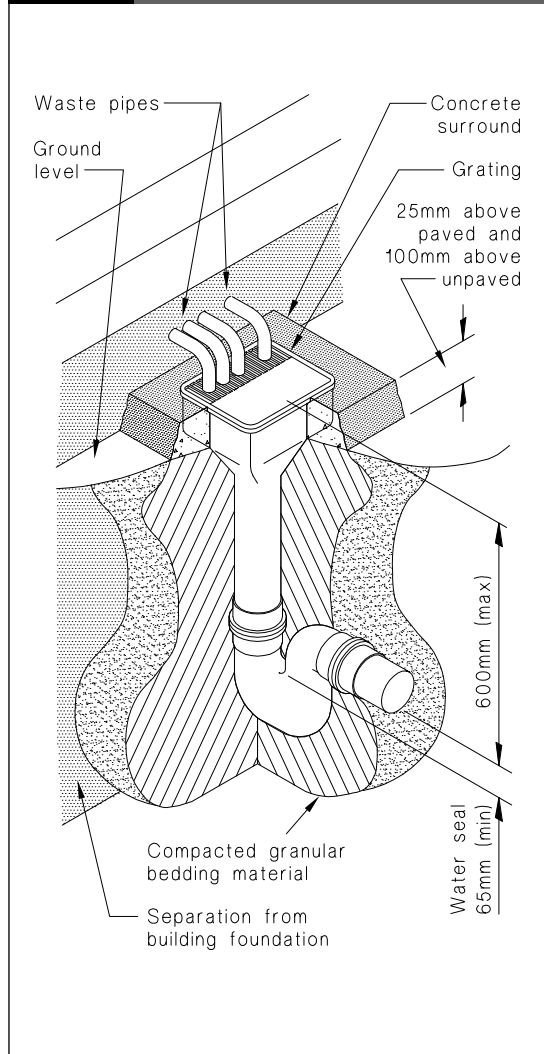

### 3.3 Gully traps

**3.3.1** All *gully traps* shall be constructed to prevent the ingress of *surface water* and foreign bodies likely to cause a blockage, shall be located within the legal boundary of the land on which the *building* is erected, and shall have (see Figures 2 and 3):

- a) The overflow level of the gully dish no less than:
  - i) 25 mm above paved surfaces, or
  - ii) 100 mm above unpaved surfaces,

**COMMENT:**

It is imperative that the *waste pipe* connections to the *gully trap* remain watertight to prevent the ingress of ground/surface water.

- b) A grating that will allow surcharge,
- c) A minimum outlet pipe *diameter* of 100 mm,
- d) A *water seal* depth of at least 65 mm,
- e) At least one *discharge pipe* discharging to the *gully trap* to avoid *water seal* evaporation,
- f) *Waste pipes* that discharge to the *gully trap* arranged to permit easy cleaning of the *gully trap*,
- g) *Waste pipe* outlets located at least 20 mm above *water seal* level, and at least 20 mm below the grating,