

# Compliance Document for New Zealand Building Code Clause G14 Industrial Liquid Waste – Second edition

Prepared by the Department of Building and Housing

This Compliance Document is prepared by the Department of Building and Housing. The Department of Building and Housing is a Government Department established under the State Sector Act 1988.

Enquiries about the content of this document should be directed to:



Department of  
Building and Housing  
*Te Tari Kaupapa Whare*

Department of Building and Housing  
PO Box 10-729, Wellington.  
Telephone 0800 242 243  
Fax 04 494 0290  
Email: [info@dbh.govt.nz](mailto:info@dbh.govt.nz)

**Compliance Documents are available from [www.dbh.govt.nz](http://www.dbh.govt.nz)**

## New Zealand Government

© Department of Building and Housing 2011

This Compliance Document is protected by Crown copyright, unless indicated otherwise. The Department of Building and Housing administers the copyright in this document. You may use and reproduce this document for your personal use or for the purposes of your business provided you reproduce the document accurately and not in an inappropriate or misleading context. You may not distribute this document to others or reproduce it for sale or profit.

The Department of Building and Housing owns or has licences to use all images and trademarks in this document. You must not use or reproduce images and trademarks featured in this document for any purpose (except as part of an accurate reproduction of this document) unless you first obtain the written permission of the Department of Building and Housing.

## Status of Compliance Documents

Compliance Documents are prepared by the Department of Building and Housing in accordance with section 22 of the Building Act 2004. A Compliance Document is for use in establishing compliance with the New Zealand Building Code.

A person who complies with a Compliance Document will be treated as having complied with the provisions of the Building Code to which the Compliance Document relates. However, a Compliance Document is only one method of complying with the Building Code. There may be alternative ways to comply.

Users should make themselves familiar with the preface to the New Zealand Building Code Handbook, which describes the status of Compliance Documents and explains alternative methods of achieving compliance.

Defined words (italicised in the text) and classified uses are explained in Clauses A1 and A2 of the Building Code and in the Definitions at the start of this Compliance Document.

<b>G14: Document History</b>			
	<b>Date</b>	<b>Alterations</b>	
First published	July 1992		
Amendment 1	September 1993	pp. vi – viii, References	
Amendment 2	1 December 1995	pp. i and ii, Document History	p. iv, G14.3.2 (d)
Second edition	21 June 2007	Document revised – second edition issued	
Amendment 3	Published 30 June 2010 Effective from 30 September 2010	p. 2, Document History, Status pp. 7–9, References	p. 19, G14/VM1 Table 3 p. 22, G14/VM1 Table 4
Amendment 4	10 October 2011	p. 2, Document History, Status p. 11, Definitions	pp. 7–9, References p. 19, G14/VM1 Table 3
<b>Note: Page numbers relate to the document at the time of Amendment and may not match page numbers in current document.</b>			

### Document Status

The most recent version of this document, as detailed in the Document History, is approved by the Chief Executive of the Department of Building and Housing. It is effective from 10 October 2011 and supersedes all previous versions of this document.

People using this Compliance Document should check for amendments on a regular basis. The Department of Building and Housing may amend any part of any Compliance Document at any time. Up-to-date versions of Compliance Documents are available from [www.dbh.govt.nz](http://www.dbh.govt.nz)

# New Zealand Building Code

## Clause G14 Industrial Liquid Waste

This Clause is extracted from the New Zealand Building Code contained in the First Schedule of the Building Regulations 2005.

<b>FIRST SCHEDULE—continued</b>	
<b>Clause G14—INDUSTRIAL LIQUID WASTE</b>	
<b>Provisions</b>	<b>Limits on application</b>
<b>OBJECTIVE</b>	
<b>G14.1</b> The objective of this provision is to safeguard people from injury or illness caused by infection or contamination resulting from industrial liquid waste.	
<b>FUNCTIONAL REQUIREMENT</b>	
<b>G14.2</b> <i>Buildings</i> in which industrial liquid waste or foul water is generated shall be provided with <i>adequate</i> spaces and facilities for the safe and hygienic collection, holding, treatment and disposal of the waste.	
<b>PERFORMANCE</b>	
<b>G14.3.1</b> Industrial liquid waste or foul water shall be conveyed to storage containers and within disposal systems in a way that will:	
<ul style="list-style-type: none"> <li>(a) Transfer wastes from <i>buildings</i> safely and hygienically,</li> <li>(b) Avoid the likelihood of blockage and leakage,</li> <li>(c) Avoid the likelihood of foul air and gases entering <i>buildings</i>, and</li> <li>(d) Provides reasonable access for clearing of blockages.</li> </ul>	
<b>G14.3.2</b> Facilities for the storage, treatment, and disposal of industrial liquid waste must be constructed—	
<ul style="list-style-type: none"> <li>(a) with <i>adequate</i> capacity for the volume of waste and the frequency of disposal; and</li> <li>(b) with <i>adequate</i> vehicle access for collection if required; and</li> <li>(c) to avoid the likelihood of contamination of any potable water supplies in compliance with Clause G12 “Water Supplies”; and</li> </ul>	

Amend 1  
Jun 2007

FIRST SCHEDULE—*continued*

Provisions	Limits on application
(d) to avoid the likelihood of contamination of soils, ground water, and waterways except as permitted under the Resource Management Act 1991; and	
(e) from materials that are impervious both to the waste for which disposal is required, and to water; and	
(f) to avoid the likelihood of blockage and leakage; and	
(g) to avoid the likelihood of foul air and gases accumulating within or entering into <i>buildings</i> ; and	
(h) to avoid the likelihood of unauthorised access by people; and	
(i) to permit easy cleaning and maintenance; and	
(j) to avoid the likelihood of damage from superimposed loads or normal ground movement; and	
(k) if those facilities are buried underground, to resist hydrostatic uplift pressures.	

Amend 1  
Jun 2007

# Contents

	<b>Page</b>
<b>References</b>	<b>7</b>
<b>Definitions</b>	<b>11</b>
<b>Verification Method G14/VM1</b>	<b>13</b>
<b>1.0 General</b>	<b>13</b>
1.1 Scope	13
1.2 Treatment and disposal	13
1.3 Related Compliance Documents	16
1.4 Location of collection, storage and treatment facilities and disposal systems	16
1.5 Materials of construction	16
1.6 Avoidance of contamination	17
1.7 Separation of wastes	17
1.8 Vehicle access	17
1.9 Security	17
<b>2.0 Conveyance of industrial liquid wastes</b>	<b>17</b>
2.1 Layout	17
2.2 Drainage	18
2.3 Piping	18
2.4 Pumps	20
<b>3.0 Storage or treatment tanks</b>	<b>22</b>
3.1 General	22
3.2 Resistance to loads	22
3.3 Liquid hazardous waste	22
<b>Acceptable Solution G14/AS1</b>	<b>25</b>
1.1 Security	25
1.2 Acceptable disposal systems	25
<b>Index</b>	<b>27</b>



# References

For the purposes of New Zealand Building Code (NZBC) compliance, the Standards and documents referenced in this Compliance Document (primary reference documents) must be the editions, along with their specific amendments, listed below. Where these primary reference documents refer to other Standards or documents (secondary reference documents), which in turn may also refer to other Standards or documents, and so on (lower-order reference documents), then the version in effect at the date of publication of this Compliance Document must be used.

Amend 4  
Oct 2011

## Standards New Zealand

NZS/BS 21: 1985 Specification for pipe threads for tubes and fittings where pressure-tight joints are made on the threads (metric dimensions)  
*Amend: 1*

Amend 3  
Sep 2010

NZS/BS 1387: 1985 Specification for screwed and socketed steel tubes and tubulars and for plain end steel tubes suitable for welding or for screwing to BS 21 pipe threads  
*Amend: 1*

Amend 3  
Sep 2010

NZS 3106: 2009 Design of concrete structures for the storage of liquids.

NZS 4219: 1983 Specification for seismic resistance of engineering systems in buildings.  
*Amend: 1, 2*

NZS 4442: 1988 Welded steel pipes and fittings for water, sewage and medium pressure gas

NZS 7601: 1978 Specification for polyethylene pipe (Type 3) for cold water services

Amend 3  
Sep 2010

## Standards Australia/Standards New Zealand

Amend 4  
Oct 2011

AS/NZS 1260: 2009 PVC-U pipes and fittings for drain, waste and vent applications

Amend 4  
Oct 2011

AS/NZS 1477: 2006 PVC pipes and fittings for pressure applications  
*Amend: 1*

Amend 4  
Oct 2011

AS/NZS 1546: On-site domestic wastewater treatment units  
Part 1: 2008 Septic tanks

Amend 3  
Sep 2010  
Amend 4  
Oct 2011

AS/NZS 2032: 2006 Installation of PVC pipe systems

AS/NZS 2033: 2008 Installation of polyethylene pipe systems  
*Amend: 1, 2*

Amend 4  
Oct 2011

AS/NZS 2642: Polybutylene pipe systems  
Part 2: 2008 Polybutylene (PB) for hot and cold water applications  
Part 3: 2008 Mechanical jointing fittings for polybutylene pipes for hot and cold water applications  
*Amend: 1*

Amend 4  
Oct 2011

## Where quoted

VM1 Table 3

VM1 Table 3

VM1 3.2.2, Table 4

VM1 3.2.1

VM1 Table 3

VM1 Table 3

VM1 Table 3

VM1 Table 3

VM1 Table 4

VM1 Table 3

VM1 Table 3

VM1 Table 3

	<b>Where quoted</b>
AS/NZS 3518: 2004 Acrylonitrile butadiene styrene (ABS) compounds, pipes and fittings for pressure applications <i>Amend: 1</i>	VM1 Table 3
Amend 3 Sep 2010   AS/NZS 4058: 2007 Pre Cast concrete Pipes (pressure and non pressure)	VM1 Table 1
Amend 4 Oct 2011   AS/NZS 4129: 2008 Fittings for polyethylene (PE) pipes for pressure applications	VM1 Table 3
Amend 4 Oct 2011   AS/NZS 4130: 2009 Polyethylene (PE) pipes for pressure applications <i>Amend: 1</i>	VM1 Table 3
AS/NZS 4331: 1995 Metallic flanges Part 1: Steel flanges Part 2: Cast iron flanges Part 3: Copper alloy and composite flanges	VM1 Table 3
Amend 3 Sep 2010   AS/NZS 4401: 2006 High density polyethylene (PE-HD) pipes and fittings for soil and waste discharge (low and high temperature) systems inside buildings	VM1 Table 3
Amend 3 Sep 2010   AS/NZS 4765: 2007 Modified polyvinyl chloride (PVC-M) pipes for pressure applications	VM1 Table 3
<b>British Standards Institution</b>	
Amend 3 Sep 2010   BS 143, and BS 1256: 2000 Specification for malleable cast iron and cast copper alloy threaded pipe fittings. <i>Amend: 1, 2, 3, 4</i>	VM1 Table 3
BS EN 1595: 1997 Pressure equipment made from borosilicate glass 3.3 – general rules for design, manufacture and testing	VM1 Table 3
Amend 3 Sep 2010	
Amend 4 Oct 2011	
Amend 3 Sep 2010	
BS 2971: 1991 Specification for Class II arc welding of carbon steel pipework for carrying fluids	VM1 Table 3
BS 4991: 1974 (1982) Specification for propylene copolymer pressure pipe	VM1 Table 3
Amend 3 Sep 2010	
BS 6374:- Lining of equipment with polymeric materials for the process industries Part 1: 1985 Specification for lining with sheet thermoplastics Part 2: 1984 Specification for lining with non-sheet applied thermoplastics Part 3: 1984 Specification for lining with stoved thermosetting resins Part 4: 1984 Specification for lining with cold curing thermosetting resins Part 5: 1985 Specification for lining with rubbers	VM1 Table 4

		<b>Where quoted</b>
	BS 6464: 1984 Specification for reinforced plastics pipes, fittings and joints for process plants	VM1 Table 3
	BS 7159: 1989 Code of practice for design and construction of glass-reinforced plastics (GRP) piping systems for individual plants or sites	VM1 Table 3
	BS 7777: 1993 Flat bottomed, vertical, cylindrical storage tanks for low temperature service	VM1 Table 4
	Part 1: Guide to the general provisions applying for design, construction and installation	
	Part 2: Specification for design and construction of single, double and full containment metal tanks for the storage of liquified gas at temperatures down to -165°C	
	Part 3: Recommendations for the design and construction of prestressed and reinforced concrete tanks and tank foundations and for the design and installation of tank insulation, tank lines and tank coating	
	BS EN 10241: 2000 Steel threaded pipe fittings	VM1 Table 3
Amend 4 Oct 2011	BS EN 12285: Workshop fabricated steel tanks	
	Part 1: 2003 Horizontal cylindrical single skin and double skin tanks for the underground storage of flammable and non-flammable water polluting liquids	VM1 Table 4
	Part 2: 2005 Horizontal cylindrical single skin and double skin tanks for the aboveground storage of flammable and non-flammable water polluting liquids	VM1 Table 4
Amend 3 Sep 2010		
	BS EN 12585: 1999 Glass plant, pipeline and fittings – Pipeline and fittings DN 15 to 1000 – compatibility and interchangeability	VM1 Table 3
Amend 3 Sep 2010 Amend 4 Oct 2011	BS EN 13121-3: 2008 GRP tanks and vessels for use above ground. Design and workmanship <i>Amend: 1 (2010)</i>	VM1 Table 4
<b>Standards Association of Australia</b>		
	AS 1741: 1991 Vitrified clay pipes and fittings with flexible joints – sewer quality	VM1 Table 3
Amend 3 Sep 2010		
Amend 4 Oct 2011	AS 3690: 2009 Installation of ABS pipe systems	VM1 Table 3
<b>New Zealand Regulations</b>		
	Hazardous Substances (Disposal) Regulations 2001	VM1 1.2.1
	The Resource Management Act 1991	VM1 1.2.1, 3.3.1



# Definitions

This is an abbreviated list of definitions for words or terms particularly relevant to this Compliance Document. The definitions for any other italicised words may be found in the New Zealand Building Code Handbook.

**Adequate** *Adequate* to achieve the objectives of the *Building Code*.

**Building** has the meaning given to it by sections 8 and 9 of the *Building Act 2004*.

**Grease trap** A device designed to intercept grease in a *foul water* discharge.

**Hazardous** Creating an unreasonable risk to people of bodily injury or deterioration of health.

**Interceptor trap** A device which will separate and retain desired liquids and solids from a liquid stream and which will provide a water barrier to prevent foul air or gas from entering any downstream system.

**Network utility operator** means a person who—

- (a) undertakes or proposes to undertake the distribution or transmission by pipeline of natural or manufactured gas, petroleum, biofuel or geothermal energy; or
- (b) operates or proposes to operate a network for the purpose of—
  - (i) telecommunication as defined in section 5 of the Telecommunications Act 2001; or
  - (ii) radiocommunications as defined in section 2(1) of the Radiocommunications Act 1989; or
- (c) is an electricity operator or electricity distributor as defined in section 2 of the Electricity Act 1992 for the purpose of line function services as defined in that section; or
- (d) undertakes or proposes to undertake the distribution of water for supply (including irrigation); or
- (e) undertakes or proposes to undertake a drainage or sewerage system

**Piping system** An assembly of pipes, pipe-fittings, gaskets, bolting and pipe supports.

**Sewer** A *drain* that is under the control of, or maintained by, a *network utility operator*.

Amend 4  
Oct 2011



# Verification Method G14/VM1

## Industrial Liquid Waste

### 1.0 General

---

#### 1.1 Scope

**1.1.1** This document describes the requirements to be satisfied by specific design for systems used for the collection, storage, treatment and disposal of industrial liquid waste.

**1.1.2** Where waste is *hazardous*, the storage facilities shall also comply with NZBC F3 Hazardous Substances and Processes.

#### 1.2 Treatment and disposal

**1.2.1** The method of treatment and disposal (see Figure 1) may include:

a) Discharge to a *sewer* either with or without pre-treatment, as permitted by the *network utility operator*.

b) Discharge to a natural waterway either with or without treatment, in accordance with the Resource Management Act 1991, or

c) Storage within the *building* site for later removal and disposal in a manner that meets the requirements of the Resource Management Act 1991 or other relevant legislation.

#### COMMENT:

The type, quality and quantity of industrial liquid waste that may be released to a sewer, natural waterway or disposed of by some other means may be covered by legislation such as the Hazardous Substances (Disposal) Regulations 2001 or by local Trade Waste Bylaws.

**1.2.2** Table 1 gives examples of industrial liquid wastes and typical treatment and disposal methods.

**Figure 1: Treatment and disposal methods**  
Paragraph 1.2.1

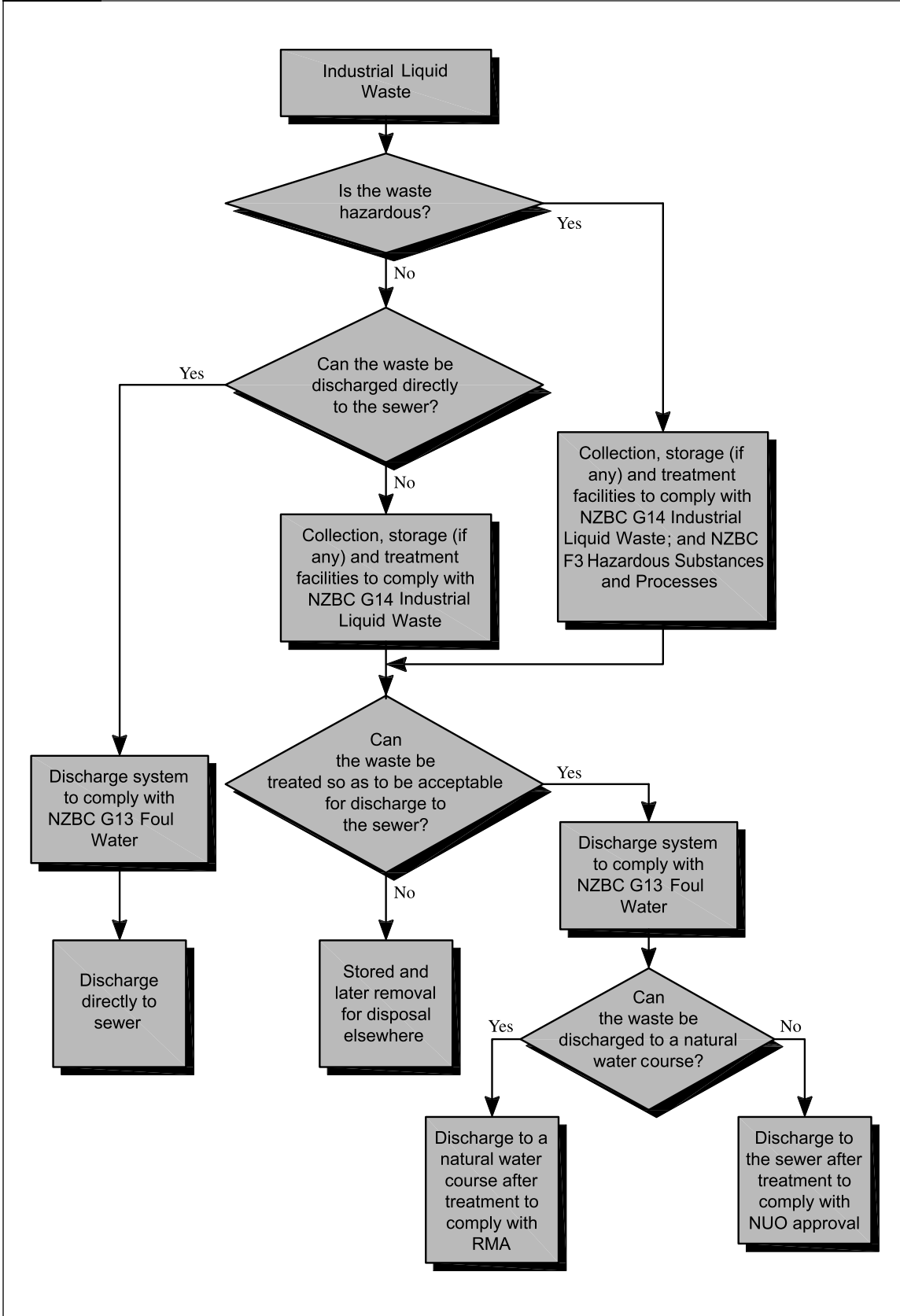

**Table 1:** Examples of industrial liquid waste and typical treatment and disposal methods (see Note)  
Paragraph 1.2.2

Type of industrial waste	Industry source	Typical contaminants	Typical treatment and disposal methods
<b>Waste containing organic compounds:</b>			
1) Natural organic waste from food and drink manufacture	Meat processing Dairy processing Canning Poultry processing Brewing Vegetable processing Wine-making Sugar refining Food processing Fish processing	Soluble and suspended solids Carbohydrates Proteins Fat and grease Alkalis	Neutralisation Grease recovery Sedimentation flotation Biological Land application Discharge to sewer
2) Other organic waste from processing animal and vegetable matter	Pulp and paper Tannery and leather processing Wool scouring Textile and carpet manufacture Timber treatment Hospitals Mortuaries	Carbohydrates Proteins Acids, alkalis Tannins Inorganic salts Dyes, bleaches Latex Suspended solids Viruses Fat and grease	Neutralisation Screening Sedimentation flotation Chemical precipitation Cooling towers Disinfection Heat
<b>Waste containing metals and cyanides</b>	Mineral processing Steel mills Foundries Plating operations Metal fabrication Electrical manufacturing	Acids, alkalis Oil Heavy metals Chromium Cyanides Solvents Suspended solids	Neutralisation Sedimentation flotation Chemical precipitation Ion exchange Filtration Distillation and steam stripping Cooling towers Heat
<b>Other chemical waste</b>	Fertiliser works Paint manufacture Pharmaceutical Petrochemical Agrochemical production Plastics manufacture	Organic chemicals Solvents Acids, alkalis Suspended solids Inorganic salts Viruses	Neutralisation Screening Sedimentation flotation Chemical treatment Absorption and ion exchange Distillation and steam stripping Membrane separation Biological Incineration Secure landfill Disinfection

## NOTE:

This table gives examples but does not purport to be an exhaustive list.

**1.3 Related Compliance Documents**

**1.3.1** Table 2 identifies the Compliance Documents that are referenced in G14/VM1.

**1.4 Location of collection, storage and treatment facilities and disposal systems**

**1.4.1** Collection, storage and treatment facilities and disposal systems shall be located:

- a) In areas that will not create health or safety hazards,
- b) To ensure that spillage from storage tanks or ponds can be safely contained, and

**COMMENT:**

Compliance Document F3/VM1 Hazardous Substances and Processes gives guidance on the requirements for the capacity of compounds intended for the containment of spillage.

- c) In areas with sufficient access for cleaning, clearing of blockages, and maintenance.

**1.4.2** Storage tanks may be placed below ground provided:

- a) Precautions are taken to avoid:
  - i) health or safety hazards,
  - ii) corrosion that threatens the integrity of the tank or associated plant, and
- b) Tanks are designed to withstand the effects of associated loads.

**1.5 Construction materials**

**1.5.1** All materials in contact with industrial liquid waste shall be resistant to corrosion, chemical attack, and any abrasion or physical abuse that can be reasonably expected.

**1.5.2** Any corrosion allowance provided in the design of equipment handling liquid waste shall be *adequate* for the *intended life* of the facilities.

**Table 2: Building Code clauses and Compliance Documents referenced in G14/VM1**  
Paragraph 1.3.1

Building Code clause	Subject	Paragraph in G14/VM1
NZBC B1 Structure and B1/VM1	Seismic restraint of tanks	3.2.1
NZBC D1 Access Routes	Vehicle access	1.8
NZBC F3 Hazardous Substances and Processes and F3/AS1	Collection and storage of hazardous liquid waste	1.1.2, Figure 1 and 1.4.1
NZBC G12 Water Supply and G12/AS1	Contamination of water supply	1.6.3
	Water hose for emergency use near storage tanks	3.3.2
NZBC G13 Foul Water and G13/AS1	Conveyance of treated wastewater	2.0.1 and Figure 1
	Drainage of water used in emergency near storage tanks	3.3.2

## 1.6 Avoiding contamination

**1.6.1** Industrial liquid waste systems, storage and treatment tanks and *pipng systems* shall be tested on completion to avoid contamination of any soil, ground water or waterways through run-off from washing-down, rain, accidental overflows or other causes.

**1.6.2** The area containing waste storage facilities shall be impervious and contained so as to avoid contamination of any soil, ground water or waterways through run-off from washing-down, rain, accidental overflows or other causes.

### COMMENT:

Compliance Document F3/VM1 Hazardous Substances and Processes gives guidance on the requirements for the capacity of compounds intended for the containment of spillage.

**1.6.3** Industrial liquid waste facilities shall be installed to avoid contamination of any potable water supply, as required by NZBC G12 Water Supplies.

## 1.7 Separation of waste

**1.7.1** Separate systems shall be provided to convey and store industrial liquid wastes that require different treatment and/or disposal methods, or where the wastes are incompatible.

### COMMENT:

This situation is usual for premises that produce both industrial liquid waste and *foul water*. Incompatibility may be due to the physical **or** chemical nature of the wastes.

## 1.8 Vehicle access

**1.8.1** Vehicle access areas for the collection of industrial liquid waste shall:

- a) Comply with NZBC D1 Access Routes.  
Where possible, access layout shall provide sufficient space for vehicles to drive in and out of the facility without reversing or interference with other activities on the site,

- b) Drain any spilled waste to a kerbed area sloped so that the waste does not collect under the vehicle, or drain in an uncontrolled manner to other areas of the plant, and
- c) Any spilled waste shall:
  - i) be contained on-site for subsequent removal,
  - ii) not enter the surface water system, and
  - iii) not enter the sewage system unless the spilled waste is acceptable as a discharge to the *sewer* by the *network utility operator*.

## 1.9 Security

**1.9.1** Where unauthorised access to storage and treatment facilities may be *hazardous*, security shall be provided by:

- a) Locating the facilities in a lockable enclosed space within a *building*, or
- b) An external security fence with lockable gates if located in the open.

## 2.0 Conveyance of industrial liquid waste

**2.0.1** Where the *network utility operator* accepts the discharge of industrial liquid waste to a *sewer*, the waste shall be conveyed in a plumbing and drainage disposal system complying with NZBC G13 Foul Water.

## 2.1 Layout

**2.1.1** Screens, grit chambers, *grease traps* or similar appropriate equipment should be installed at the head of *pipng systems* if suspended solids or material within the liquid waste might cause blockage of the *pipng system*.

**2.1.2** Wherever possible, *pipng systems* shall convey industrial liquid waste using gravity flow.

**2.1.3** Gravity flow pipelines should have sufficient gradient to provide flow velocities that prevent the settlement of entrained solids and grit.

**2.1.4** Pipework containing *hazardous* liquid waste shall not be buried except where this is unavoidable.

**2.1.5** Piping above access areas shall have a ground clearance of no less than 4.5 m. In vehicle access areas, signs shall be displayed indicating the amount of clearance.

**2.1.6** Valves shall be readily accessible. The distance between operating floor level and the centreline of any valve handwheels located above floor level shall be no more than 2.2 m, unless extension operating gear is provided. Valve stems shall not slope downwards in a way that allows solids to enter the gland.

**2.1.7** Pipework flanges shall not be located over roads, walkways or cable trays, or places where leakage could cause damage or a hazard.

## 2.2 Drainage

**2.2.1** Floor surfaces used to drain free flowing liquid should slope towards waste collection systems:

- a) For non-*hazardous* waste – no less than 1 in 80 for a travel distance of no more than 12.0 m, or

- b) For *hazardous* waste – no less than 1 in 40 for a travel distance of no more than 6.0 m.

### COMMENT:

Drainage valleys should not coincide with access ways. Kerbs may be required to prevent hazardous liquid waste contaminating access areas or mixing with other fluids.

**2.2.2** Industrial liquid waste shall be prevented from polluting or overflowing onto adjacent property.

**2.2.3** *Interceptor traps* shall be installed at the exit points of areas containing flammable liquid waste that is immiscible in water, to prevent the spread of *fire*.

**2.2.4** Liquid-sealed traps shall be provided at any branch connections to contain *hazardous* gases within parts of the conveyance system. Traps shall be vented to a safe location no less than 3.0 m above ground level.

**2.2.5** *Grease traps* shall be provided where liquid waste is likely to convey grease.

### COMMENT:

Grease solids shall not be allowed to accumulate to an extent that the *grease trap* is blocked. Refer to G13/AS2.

## 2.3 Piping

**2.3.1** The *piping system* shall comply with the Standards applicable to the material used and waste being conveyed. Related Standards are listed in Table 3.

**Table 3: Standards relevant to piping systems**  
Paragraph 2.3.1

Material	System	Standards	Special conditions	
Amend 3 Sep 2010	Steel	Piping	NZS 4442 NZS/BS 1387	Welded pipe 100 to 1000 mm nominal diameter Tube suitable for screwing to BS 21
	Fittings		BS 143 and BS 1256	Screwed pipe fittings, malleable cast iron
			BS EN 10241 AS/NZS 4331	Screwed pipe fittings, wrought steel Flanges
Amend 3 Sep 2010	Jointing	NZS/BS 21	Screwed/socketed	
Amend 3 Sep 2010	Concrete	Piping	BS 2971	Welded
Amend 4 Oct 2011			AS/NZS 4058	Precast concrete
Amend 3 Sep 2010	Plastic (see Note 1)	ABS	AS/NZS 3518 AS 3690	Pipes and fittings Installation
Amend 3 Sep 2010		Polybutylene piping	AS/NZS 2642	Pipes and fittings
		Polyethylene piping	NZS 7601	Maximum working pressure up to 0.9 MPa
			AS/NZS 4130	Pipe for pressure applications
			AS/NZS 4129	Fittings for pressure applications
Amend 3 Sep 2010		Polypropylene Copolymer piping	AS/NZS 4401	Soil and waste systems
	AS/NZS 2032		Installation and jointing techniques for above and below ground	
Amend 3 Sep 2010	PVC piping	BS 4991	For temperatures up to 100°C	
		AS/NZS 1260	Drain waste and venting	
		AS/NZS 1477	Pipes and fittings for pressure applications	
Amend 3 Sep 2010	Reinforced piping	AS/NZS 4765	Pipes for pressure applications	
		AS/NZS 2032	Installation of PVC-U pipe above and below ground	
Amend 3 Sep 2010	Ceramic	Piping	BS 6464 BS 7159	For glass reinforced piping system and fittings
		Piping	AS 1741	Pipe and fittings for waste
Amend 4 Oct 2011	Glass	Piping	BS EN 1595	Borosilicate glass 3.3 pipe and fittings – design, manufacture, testing
			BS EN 12585	Glass pipeline and fittings nominal sizes

**NOTE:**

1. The pressure resistance of plastic piping and fittings is significantly reduced at elevated temperatures. Manufacturers' data should be consulted for working temperatures above 20°C.

**2.3.2 Joints, fittings and valves** – The number of joints, fittings and valves in the *piping system* shall be kept to a practical minimum.

**COMMENT:**

This reduces the likelihood of blockage and leakage.

**2.3.3 Bends** shall have a centreline radius of no less than 1.5 times the nominal pipe diameter.

**2.3.4 Pipe wall thickness** shall be designed to avoid failure, paying due regard to:

- a) Operating temperature and pressure,
- b) Corrosion and erosion allowances, and
- c) Manufacturing tolerances.

**2.3.5 Thermal movement** – Piping layouts shall allow for expansion and contraction due to temperature change, without placing excessive stresses on piping materials, or excessive forces and moments on equipment anchors. Methods of accommodating thermal movement in piping may include:

- a) Positioning of connected equipment to take advantage of the inherent flexibility of pipework,
- b) Expansion loops or offset legs,
- c) Expansion bellows units,
- d) Expansion joints, and
- e) Accommodation of stresses by control of expansion direction via supports, anchors and guides.

**2.3.6 Piping systems** for *hazardous* liquid waste shall have:

- a) Flanged or butt-welded joints,
- b) Fail-safe control valves, normally closed,
- c) Protection against temperature both from the fluid conveyed or the occurrence of *fire*,
- d) Metal reinforced, spiral-wound and ring-jointed gaskets of a material suitable for the temperature and the waste being handled, and
- e) Protection against over-pressure.

**COMMENT:**

Threaded joints weaken the pipe, are particularly prone to leakage, and perform poorly in corrosive service. When leakage around the valve stem cannot be tolerated, valves with double packing boxes or with a bellows seal should be used.

**2.4 Pumps**

**2.4.1** Pumps shall be designed with regard to:

- a) The required capacity and flow rate,
- b) Maximum internal or external coincident pressure,
- c) Minimum or maximum temperatures expected in service,
- d) The suspended solids likely to be present in the liquid waste,
- e) Protection against leakage, by the selection of an appropriate chemically-resistant seal packing material,
- f) Minimising the length of suction lines, and providing the required net positive suction head,
- g) Ensuring any spillage is conducted away from the pump and motor,
- h) Providing a means of isolation for maintenance purposes, and
- i) Providing an appropriate alarm system to monitor pump operation failure and liquid waste overflow.

**2.4.2** Where suspended solids are likely to cause blockages, centrifugal pumps having a suction inlet diameter of no less than 100 mm shall be used.

**2.4.3** Typical pump installation layouts are shown in Figure 2.

**2.4.4** When *hazardous* liquid waste is to be conveyed, pumps shall:

- a) Be sealless or glandless pumps, and
- b) Include a remotely or automatically actuated shut-off valve in the pump inlet line.

**Figure 2:** Typical pump layout arrangements to convey liquid industrial waste  
Paragraph 2.4.3

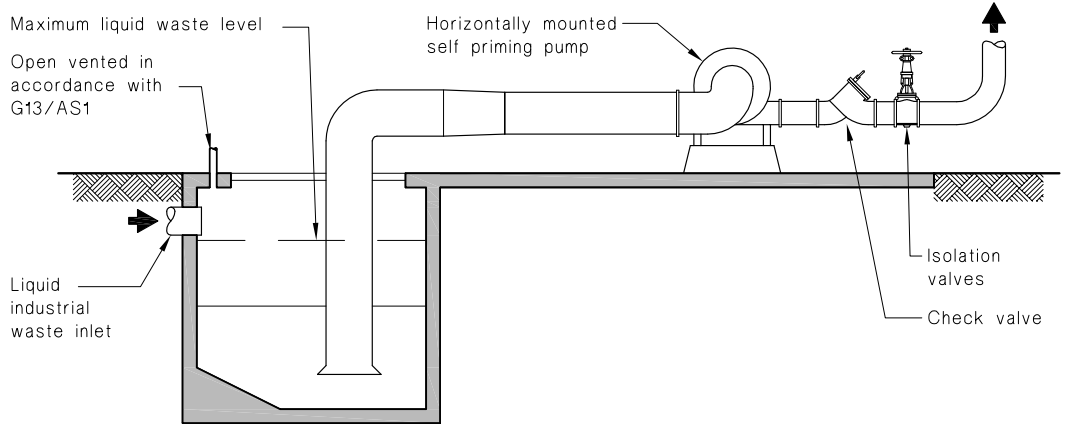

(a) Dry-pit pump set for solids handling with flooded suction

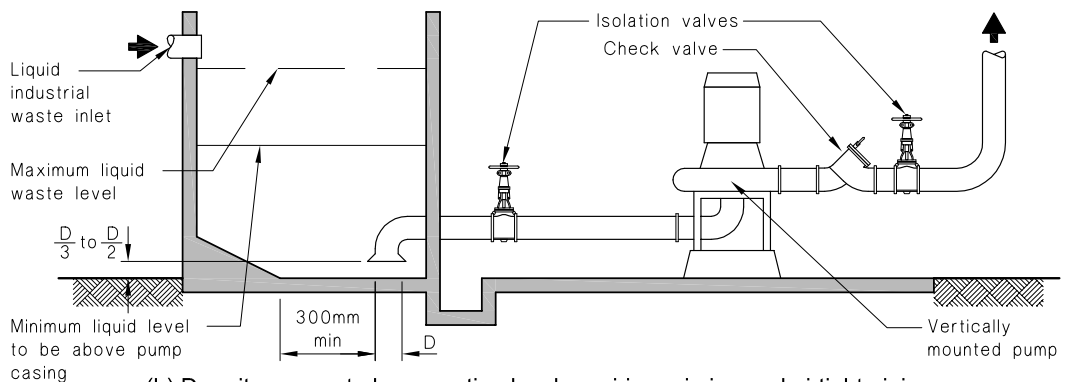

(b) Dry-pit pump set above suction level requiring priming and airtight piping

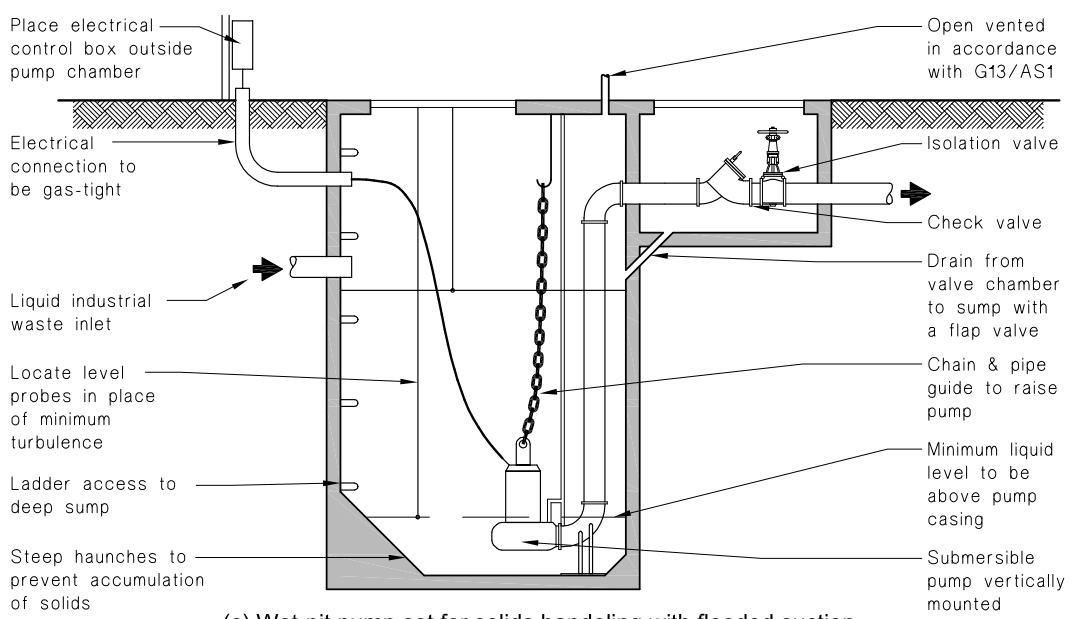

(c) Wet-pit pump set for solids handling with flooded suction

**3.0 Storage or treatment tanks**

**3.1 General**

**3.1.1** The design and construction of storage tanks shall comply with NZBC Clause B1 Structure. Appropriate Standards are given in Table 4.

**3.1.2** Storage tanks shall be fitted with an accurate liquid level indicator that can be easily removed from the tank for maintenance purposes, without the need to empty the tank.

**3.2 Resistance to loads**

**3.2.1** Free-standing tanks shall be secured against earthquake forces. The methods given in NZS 4219 are acceptable.

**COMMENT:**  
NZBC Clause B1, through B1/VM1, requires building services to be secured against earthquake forces.

**3.2.2** Storage and treatment tanks that are buried shall be designed to withstand super-imposed loads and uplift forces. The methods given in NZS 3106 for concrete tanks are acceptable.

**3.3 Liquid hazardous waste**

**3.3.1** Tanks for the storage of toxic or corrosive liquid *hazardous* waste, or waste producing foul air, shall be fitted with sealed covers and be provided with a pressure relief system that vents to a safe outdoor location.

**COMMENT:**  
1) A safe location does not necessarily include the *sewer* or surface water system.  
2) Where the pressure relief system results in regular discharges to the environment, then the owner or operator should approach the regional council to determine consent requirements under a Regional Plan or the Resource Management Act 1991.

**3.3.2** Within the immediate vicinity of any toxic and corrosive liquid waste, a safety shower, eyewash unit and a wash-down hose complying with G12/AS1 and G13/AS1 shall be provided, and be clearly identified.

**3.3.3** A typical tank storage facility for corrosive liquid waste is shown in Figure 3.

**Table 4: Standards used for the design of acceptable tank storage systems** (see Note)  
Paragraph 3.1.1

Material	Standards	Special Conditions
<b>Steel</b>	BS EN 12285.1	Horizontal cylindrical vessels
	BS EN 12285.2	Horizontal cylindrical vessels
	BS 7777	Design, construction, installation, cold storage
<b>Concrete</b>	NZS 3106	–
	AS/NZS 1546.1	For up to 10 people and 14,000 litres/week
<b>Plastic</b>	BS EN 13121.3	Above ground GRP tanks
	BS 6374	For tank linings
	AS/NZS 1546.1	For up to 10 people and 14,000 litres/week

**NOTE:**  
In all cases Standards must be used only for applications appropriate to the liquid waste being stored.

Amend 3  
Sep 2010

Amend 3  
Sep 2010

**Figure 3: Typical tank storage facility for a corrosive liquid waste**  
Paragraph 3.3.3

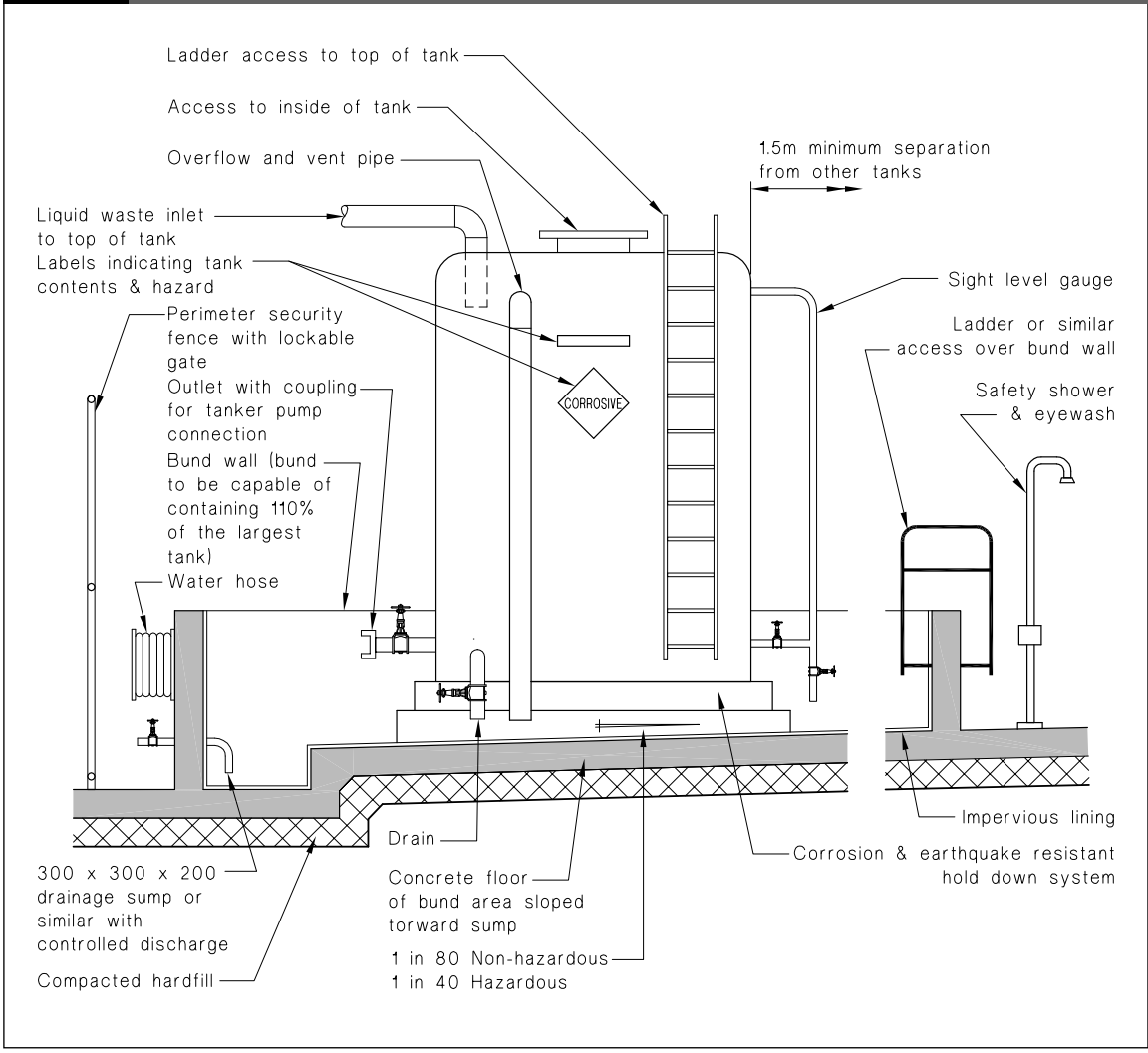



# Acceptable Solution G14/AS1

## Industrial Liquid Waste

### 1.1 Security

---

**1.1.1** A fence erected to ensure security against unauthorised access to storage and treatment facilities shall comply with F5/AS1 Construction and Demolition Hazards.

### 1.2 Acceptable disposal systems

**1.2.1 Discharge to the sewer without pre-treatment** – Where the *network utility operator* accepts the discharge of industrial liquid waste to a *sewer* without pre-treatment, the disposal system shall comply with Compliance Document G13 Foul Water.

**1.2.2 Discharge to the sewer after pre-treatment** – Where the *network utility operator* accepts the discharge of industrial liquid waste to a *sewer* with pre-treatment, that part of the discharge system used to convey the waste after treatment shall comply with Compliance Document G13 Foul Water.



# Index G14/VM1 & AS1

All references to Verification Methods and Acceptable Solutions are preceded by **VM** or **AS** respectively.

<b>Contaminants</b> .....	<b>VM1</b> 1.6, Table 1
<b>Ground water</b> .....	<b>VM1</b> 1.6.1
<b>Industrial liquid waste</b>	
collection .....	<b>VM1</b> 1.1.1, 1.4
location of facilities .....	<b>VM1</b> 1.4
conveyance systems .....	<b>VM1</b> 2.0
drainage .....	<b>VM1</b> 2.2
piping systems .....	<b>VM1</b> 2.3, Table 3
pumps .....	<b>VM1</b> 2.4, Figure 2
corrosion .....	<b>VM1</b> 1.5.1, 1.5.2
disposal .....	<b>VM1</b> 1.1.1, Table 1, Figure 1
location of facilities .....	<b>VM1</b> 1.4
to a natural waterway .....	<b>VM1</b> 1.2.1 b)
to a sewer .....	<b>VM1</b> 1.2.1 a), <b>AS1</b> 1.2.1, 1.2.2
hazardous wastes .....	<b>VM1</b> 1.4.1 b), 1.9.1, 2.1.4, 2.2.1 b), 2.2.4, 2.3.6, 2.4.4, 3.3
materials used in construction .....	<b>VM1</b> 1.5
safety facilities .....	<b>VM1</b> 3.3.2
separate waste systems .....	<b>VM1</b> 1.7.1
storage .....	<b>VM1</b> 1.1.1, 1.2.1 c), 1.4
location of facilities .....	<b>VM1</b> 1.4
storage tanks .....	<b>VM1</b> 1.4.1 b), 1.4.2, 3.0
seismic restraint .....	<b>VM1</b> 3.2.1
treatment .....	<b>VM1</b> 1.1.1, 1.2, 1.2.2, 1.4, Figure 1, Table 1
location of facilities .....	<b>VM1</b> 1.4
<b>Industry</b>	
types .....	<b>VM1</b> 1.2.2, Table 1
<b>Network utility operator</b> .....	<b>VM1</b> 1.2.1 a), <b>AS1</b> 1.2.1, 1.2.2
<b>Security</b> .....	<b>VM1</b> 1.9 <b>AS1</b> 1.1
<b>Vehicle Access</b> .....	<b>VM1</b> 1.8, 2.1.5
<b>Water Supplies</b>	
potable .....	<b>VM1</b> 1.6.3

