

Compliance Document for New Zealand Building Code Clause F8 Signs

Prepared by the Department of Building and Housing

This Compliance Document is prepared by the Department of Building and Housing. The Department of Building and Housing is a Government Department established under the State Sector Act 1988.

Enquiries about the content of this document should be directed to:



Department of
Building and Housing

Te Tari Kaupapa Whare

Department of Building and Housing
PO Box 10-729, Wellington.
Telephone 0800 242 243
Fax 04 494 0290
Email: info@dbh.govt.nz



Sales enquiries should be directed to:
Customer Services,
Victoria University Book Centre
PO Box 12-337, Wellington, New Zealand
Telephone 0800 370 370, (04) 463 5511
Fax (04) 463 5510
Email: dbh@vicbooks.co.nz
www.vicbooks.co.nz
ISBN 0-477-01606-5

© Department of Building and Housing 2006

This Compliance Document is protected by Crown copyright, unless indicated otherwise. The Department of Building and Housing administers the copyright in this document. You may use and reproduce this document for your personal use or for the purposes of your business provided you reproduce the document accurately and not in an inappropriate or misleading context. You may not distribute this document to others or reproduce it for sale or profit.

The Department of Building and Housing owns or has licences to use all images and trademarks in this document. You must not use or reproduce images and trademarks featured in this document for any purpose (except as part of an accurate reproduction of this document) unless you first obtain the written permission of the Department of Building and Housing.

Status of Compliance Documents

Compliance Documents are prepared by the Department of Building and Housing in accordance with section 22 of the Building Act 2004. A Compliance Document is for use in establishing compliance with the New Zealand Building Code.

A person who complies with a Compliance Document will be treated as having complied with the provisions of the Building Code to which the Compliance Document relates. However, a Compliance Document is only one method of complying with the Building Code. There may be alternative ways to comply.

Users should make themselves familiar with the preface to the New Zealand Building Code Handbook, which describes the status of Compliance Documents and explains alternative methods of achieving compliance.

Defined words (italicised in the text) and classified uses are explained in Clauses A1 of the Building Code and in the Definitions at the start of this Compliance Document.

F8: Document History			
	Date	Alterations	
First published	July 1992		
Amendment 1	September 1993	p. v, Contents p. vi, References p. 4, Table 2 p. 11, 6.4.2 a)	p. 12, 6.4.3, Figures 11, 12, 13, 14, 6.5.1 p. 13, 6.6.3, 6.7.1, Figures 15, 16 pp. 15-16 Index
Note: Page numbers relate to the document at the time of Amendment and may not match page numbers in current document.			

Document Status

The most recent version of this document, as detailed in the Document History, is approved by the Chief Executive of the Department of Building and Housing. It is effective from September 1993 and supersedes all previous versions of this document.

People using this Compliance Document should check for amendments on a regular basis. The Department of Building and Housing may amend any part of any Compliance Document at any time. Up-to-date versions of Compliance Documents are available from www.dbh.govt.nz

New Zealand Building Code

Clause F8 Signs

This Clause is extracted from the New Zealand Building Code contained in the First Schedule of the Building Regulations 1992.

FIRST SCHEDULE—continued	
Clause F8—SIGNS	
Provisions	Limits on application
<p>OBJECTIVE</p> <p>F8.1 The objective of this provision is to:</p> <ul style="list-style-type: none"> (a) Safeguard people from injury or illness resulting from inadequate identification of <i>escape routes</i>, or of hazards within or about the <i>building</i>, (b) Safeguard people from loss of <i>amenity</i> due to inadequate direction, and (c) Ensure that <i>people with disabilities</i> are able to carry out normal activities and processes within <i>buildings</i>. <p>FUNCTIONAL REQUIREMENT</p> <p>F8.2 Signs shall be provided in and about <i>buildings</i> to identify:</p> <ul style="list-style-type: none"> (a) <i>Escape routes</i>, (b) Emergency related safety features, (c) Potential hazards, and (d) <i>Accessible routes</i> and facilities for <i>people with disabilities</i>. <p>PERFORMANCE</p> <p>F8.3.1 Signs shall be clearly visible and readily understandable under all conditions of foreseeable use.</p> <p>F8.3.2 Signs indicating potential hazards shall be provided in sufficient locations to notify people before they encounter the hazard.</p> <p>F8.3.3 Signs to facilitate escape shall:</p> <ul style="list-style-type: none"> (a) Be provided in sufficient locations to identify <i>escape routes</i> and guide people to a <i>safe place</i>, and 	<p>Objective F8.1 (c) shall apply only to those <i>buildings</i> to which section 25 of the Disabled Persons Community Welfare Act 1975 applies.</p> <p>Requirement F8.2 shall not apply to <i>Detached Dwellings</i>, or within <i>household units of Multi-unit Dwellings</i>.</p>

FIRST SCHEDULE—*continued***Provisions**

- (b) Remain visible in the event of a power failure of the main lighting supply, for the same duration as required by Clause F6 “Lighting for Emergency”.

F8.3.4 Signs shall be provided in sufficient locations to identify *accessible routes* and facilities provided for *people with disabilities*.

Limits on application

Contents

	Page
References	7
Definitions	9
Verification Method F8/VM1	11
Acceptable Solution F8/AS1	13
1.0 Lettering Type and Proportioning for Signs	13
2.0 Safety Signs	14
2.1 Safety colours	14
2.2 Sign layout	14
2.3 Design of safety symbols	15
3.0 Escape Routes	15
3.1 Location	15
3.2 Wording	15
3.3 Sign details	16
3.4 Colour	16
3.5 Illumination	16
4.0 Fire Related Safety Features	18
4.1 Call points	18
4.2 Fire and smoke control doors	18
5.0 Access and Facilities for People with Disabilities	18
6.0 Potential Hazards	19
6.1 Dangerous goods	19
6.2 Electrical hazards	21
6.3 Floor loadings	21
6.4 Fire safety	21
6.5 Machine rooms	22
6.6 Escalators and moving walks	23
6.7 Water supplies	23
Index	25

Amend 1
Sep 1993

References

Amend 1
Sep 1993

For the purposes of New Zealand Building Code compliance, acceptable reference documents include only the quoted edition and specific amendments as listed below.

Amend 1
Sep 1993

Standards New Zealand

NZS 4231: 1985 Specification for self-luminous exit signs
Amend: A

NZS/BS 5252: 1976 Framework for colour co-ordination for building purposes
Amend: 1

NZS 6742: 1971 Code of practice for emergency lighting in buildings

British Standards Institution

Amend 1
Sep 1993

BS 5378:- Safety signs and colours
Part 1: 1980 Specification for colour and design

Where quoted

AS1 3.5.4

AS1 Table 2

AS1 3.5.5

AS1 2.3.2

Definitions

This is an abbreviated list of definitions for words or terms particularly relevant to this Approved Document. The definitions for any other italicised words may be found in the New Zealand Building Code Handbook.

Access route A continuous route that permits people and goods to move between the apron or *construction edge* of the *building* to spaces within a *building*, and between spaces within a *building*.

Accessible Having features to permit reasonable use by *people with disabilities*.

Accessible route An *access route* usable by *people with disabilities*. It shall be a continuous route that can be negotiated unaided by a wheelchair user. The route shall extend from street boundary or car parking area to those spaces within the *building* required to be *accessible* to enable *people with disabilities* to carry out normal activities and processes within the *building*.

Active conductor Any *conductor* in which the electrical potential differs from that of a neutral *conductor* or earth.

Adequate *Adequate* to achieve the objectives of the *building code*.

Building has the meaning ascribed to it in the Building Act 1991.

Controlled area That area where the use of radioactive material or an irradiating apparatus may, in the opinion of the *licensee*, present a hazard to persons within that area.

Dangerous goods Any materials included in the UN classification, Classes 2-5.

Dangerous goods workroom A room reserved primarily for the use of *dangerous goods* of class 3(a) or class 3(b) (i.e. inflammable liquids).

Doorset A complete assembly comprising a door leaf or leaves including any glazed or solid panels adjacent to or over the leaves within the door frame including hardware or other inbuilt features; and a door frame, if any, with its fixings to the wall and, for a sliding or tilting door, all guides and their respective fixings to the lintel, wall or sill.

Escape route A continuous unobstructed route from any *occupied space* in a *building* to a *final exit* to enable occupants to reach a *safe place*, and shall comprise one or more of the following: *open paths*, *protected paths* and *safe paths*.

Exitway All parts of an *escape route* protected by *fire* or *smoke separations*, or by distance, when exposed to open air, and terminating at a *final exit*.

Final exit The point at which an *escape route* terminates by giving direct access to a *safe place*.

Fire The state of combustion during which flammable materials burn producing heat, toxic gases, or smoke or flame or any combination of these.

Fire door A *doorset*, single or multi-leaf, having a specific *fire resistance rating*, and in certain situations a smoke control capability, and forming part of a *fire separation*.

COMMENT:

Requirements for *fire doors* are given in C3/AS1 Paragraph 5.0 and Appendix E.

Handrail A rail to provide both support to, or assist with the movement of a person.

Hold open device A device which holds a *fire door* open during normal use, but is released by deactivating the device by an alarm sensing element, allowing the door to close under the action of a *self-closing device*.

Illuminance The luminous flux falling onto a unit area of surface.

Licensee A person holding a license issued under the Radiation Protection Act 1965 and for the time being in force.

Open path That part of an *escape route* (including *dead ends*) not protected by *fire* or *smoke separations*, and which terminates at a *final exit* or *exitway*.

People with disabilities People whose ability to use *buildings* is affected by mental, physical, hearing or sight impairment.

Safe path That part of an *exitway* which is protected from the effects of *fire* by *fire separations*, *external walls*, or by distance when exposed to open air.

Safety colour (green, red or yellow) A colour of specified properties to which a safety meaning is attributed.

Safety sign A particular type of sign which comprises a geometric form and a *safety colour*, together with a *safety symbol* or text (that is, words, letters numbers or a combination of these) and gives a particular safety message.

Safety symbol means a graphic symbol used in a *safety sign*.

Smoke control door A *doorset* with close fitting single or multi-leaves which are impermeable to the passage of smoke, fitted with smoke seals and forming part of a *smoke separation*.

COMMENT:

Requirements for *smoke control doors* are given in C3/AS1 Paragraph 5.0.

Smoke separation Any vertical, horizontal or inclined *building element* with known smoke-stopping or smoke-leakage characteristics.

Verification Method F8/VM1

No specific test methods have been adopted for verifying compliance with the Performance of NZBC F8.

Acceptable Solution F8/AS1

1.0 Lettering Type and Proportioning of Signs

1.0.1 Vertical block type lettering using full strokes shall be used.

1.0.2 The letter proportions are as set out in Table 1.

1.0.3 The thickness of the letter (d) can vary between 15% and 30% of the height of the letter (h).

COMMENT:

Acceptable type sets complying with Paragraph 1.0 are Helvetica and Univers.

Note that for Helvetica bold $d = 0.3 h$ and for Helvetica condensed $d = 0.15 h$.

Table 1: Proportioning of Lettering
Paragraph 1.0.2 and Table 4

Dimensions	Ratio	Examples of dimensions (mm)							
<i>h</i>	$(10/10) h$	10	20	25	40	50	75	100	125
<i>c</i>	$(7/10) h$	7	14	17.5	28	35	52.5	70	87.5
<i>a</i>	$(2/10) h$	2	4	5	8	10	15	20	25
<i>b</i>	$(14/10) h$	14	28	35	56	70	105	140	175
<i>e</i>	$(6/10) h$	6	12	15	24	30	45	60	75

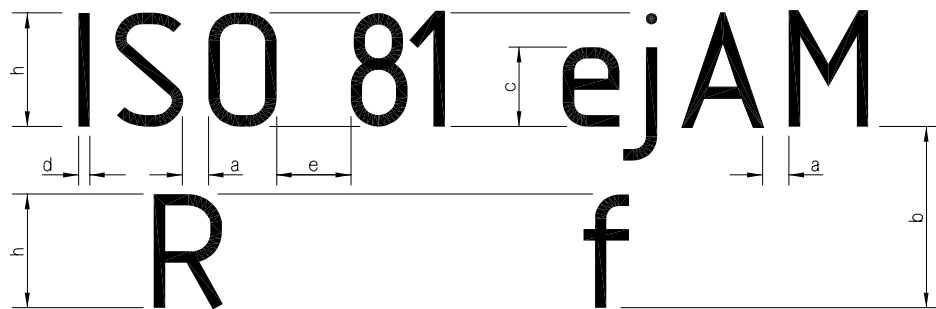

2.0 Safety Signs

2.1 Safety colours

2.1.1 The colours for *safety signs* shall comply with Table 2.

2.1.2 The choice of *safety colours* shall comply with Table 3.

Table 2: Safety Colours
Paragraph 2.1.1

Safety colour	Specification
Reference standard	Colour number
Safety Red 04E53	NZS/BS 5252
Safety Yellow 08E51	NZS/BS 5252
Safety Green 14E53	NZS/BS 5252

Amend 1
Sep 1993

2.2 Sign layout

2.2.1 Prohibition and stop signs

Prohibition and stop signs shall:

- a) Be circular with a white background, a circular band and crossbar of *safety red*, and a black *safety symbol* centrally placed on the background without obliterating the crossbar,

- b) Have the background colour displayed over no less than 35% of the sign face, and
- c) Have the proportions given in Figure 1. (The *safety symbol* is omitted from this example.)

2.2.2 Caution signs

Caution signs shall:

- a) Be of an equilateral triangle with a background of *safety yellow*, a black perimeter band, and a black *safety symbol* or text located centrally on the background.
- b) Have the background colour displayed over no less than 50% of the sign face, and
- c) Have the proportions given in Figure 2. (The *safety symbol* is omitted from this example.)

2.2.3 Safe condition signs

Safe condition signs shall:

- a) Be rectangular or square with a background of *safety green*, and a white *safety symbol* or text placed centrally on the background, and
- b) Have the background displayed over no less than 50% of the sign face.

COMMENT:

The choice of square or rectangular shape will generally relate to requirements of the *safety symbol* or text.

Table 3: Safety Colours and Contrasting Colours
Paragraph 2.1.2

Safety colour	Meaning or purpose	Examples of use	Contrasting colour (if required)	Symbol colour
Red	Stop Prohibition	Stop signs Prohibition signs	White	Black
Yellow	Caution, risk of danger	Indication of hazards (fire, explosion, radiation, chemical etc.) Warning signs	Black	Black
Green	Safe condition	Emergency exit signs	White	White

Figure 1: Sign Proportions for Prohibition and Stop Signs
Paragraph 2.2.1 c)

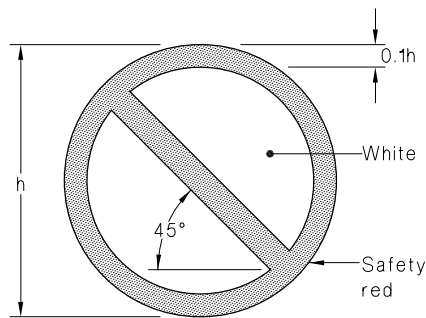
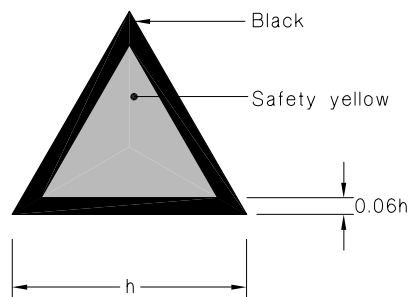

Figure 2: Sign Proportions for Caution Signs
Paragraph 2.2.2 d)



2.3 Design of safety symbols

2.3.1 The design of the *safety symbol* shall be as simple as possible and details not essential for the understanding of the message are to be omitted.

2.3.2 Examples of acceptable *safety symbols* are given in the Appendix to BS 5378 Part 1.

3.0 Escape Routes

3.1 Location

3.1.1 *Escape routes* shall be identified by exit signs which are to be located:

- At each point in the *open path* where a door giving access to a *final exit* or an *exitway* is not visible in normal use,
- To clearly indicate each door giving access to a *final exit* or an *exitway*, and
- To clearly identify the route of travel through the *exitway*.

3.1.2 Where exit signs are provided to identify a door on an *escape route*, the sign shall be positioned on the leaf at or above handle height, or on a vertical surface within 600 mm of the door. The sign shall be positioned where it is least likely to be obscured from view.

3.2 Wording

3.2.1 Exit signs shall be *safety signs* complying with Paragraph 2.2.3, and display the word(s) EXIT or FIRE EXIT, plus a direction arrow if necessary, to identify the *escape route*.

3.2.2 Where a direction arrow is incorporated as part of the exit sign, a clearance of at least 25 mm shall be provided between the word(s) and the arrow.

3.2.3 In addition the following signs shall be provided:

- Where any door leads to a lower or upper level from an *exitway* and not to the *final exit*, that door shall be identified by a sign reading NO EXIT.
- Where any door in a *safe path* is at a level where *smoke separations* are required by the acceptable solution to NZBC C2 "Means of Escape", and that door leads to an alternative *exitway*, it shall be identified by signs on both sides reading ALTERNATIVE EXIT.

3.3 Sign details

3.3.1 Height of lettering

- a) Sign lettering heights shall comply with Table 4.
- b) In theatres, cinemas and public halls the letters shall be no less than 100 mm high.

Table 4: Height of Lettering
Paragraphs 3.3.1 a) and 6.1.3

Viewing distance	Letter height 'h' mm
0 - 20 m	50
20 - 30 m	75
30 - 40 m	100
40 - 50 m	125

Note:
'h' refers to the letter height as illustrated in Table 1.

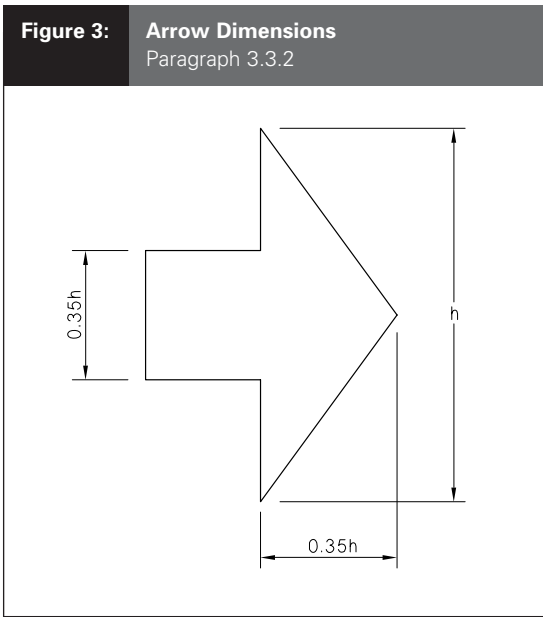

3.3.2 Arrow

The height of the arrow shall match the height of the lettering in the sign. Arrow proportioning shall comply with Figure 3.

3.3.3 Background

The background shall extend at least 15 mm beyond the words (and arrow if incorporated) displayed on the sign.

3.4 Colour

3.4.1 Except as given in Paragraph 3.4.2 the text of an exit sign, and the direction arrow where incorporated, shall be white on a *safety green* background.

3.4.2 The sign described in Paragraph 3.2.3 a) shall comprise white text on a *safety red* background.

3.4.3 Where an exit sign is internally illuminated and normally viewed under dimmed lighting conditions e.g. theatres, auditoria, and the like, the text of the sign (and direction arrow if any) may be *safety green* on a black (opaque) background. In the case of signs as described in Paragraph 3.2.3 a) these may have a text in *safety red* on a black (opaque) background.

3.5 Illumination

3.5.1 Exit signs shall be provided with external or internal lighting, or the sign may be self-luminous. Photoluminescent signs are not acceptable.

COMMENT:

1. Exit signs shall be visible at all times that the *building* is in use. In most situations the sign will be visible by means of illumination from the general lighting, however in some instances specific lighting, either internal or external or self-luminous fittings, will be required. Theatres, auditoria and the like where normal lighting levels are low, are examples of where specific lighting would be required.
2. Internally illuminated signs are preferred to externally illuminated ones as they are a self-contained unit and are more easily seen in smoky conditions. Self luminous signs, although permitted, should only be used where it is impractical to use anything else.

3.5.2 Externally illuminated exit signs

Signs which rely for their visibility on illumination from an exterior source shall have:

- a) An *illuminance* of no less than 55 lux provided at the face of the sign,
- b) A variation of *illuminance* of no greater than 3:1,
- c) Luminaires positioned so that the clarity of the sign message is not reduced at the required viewing positions, by reflections on the sign face, and

- d) The luminaires screened from the view of people passing through the area.

3.5.3 Internally illuminated exit signs

Signs which rely for their visibility on internal illumination shall comply with the following requirements:

- a) For exit signs with a white text and *safety green* background:
- i) the luminance of the background within 25 mm of the text shall be no less than 8 cd/m²,
 - ii) the ratio of the luminance of the text to that of the background shall be no less than 4:1, and
 - iii) the variation in luminance within the text and within the background shall be no more than 5:1.
- b) For exit signs with a *safety green* legend and a black (opaque) background:
- i) the luminance of the text shall lie within the range 2 cd/m² to 25 cd/m², and
 - ii) the variation in luminance within the text shall be no more than 5:1.

3.5.4 Self-luminous exit signs

Self-luminous exit signs shall comply with NZS 4231 modified as follows:

Clause 1 Delete, and replace with:

"1. Scope

This document describes an acceptable solution for the manufacture, installation and testing of self-luminous exit signs. These fittings are self-energising in respect of luminosity and require no external source of power."

Clause 5.1 Replace the words "figure 1" with "F8/AS1".

Clause 6.1 Reword to read:

"The background of the sign shall extend no less than 25 mm beyond the lettering (and arrow if appropriate) at the sides, and 31 mm at the top and bottom."

Clause 7.1 Delete the last sentence of the first paragraph.

Clause 8 Delete.

Clause 9.1 Delete the words "if required".

Clause 13.1 Replace the words "basic radiation symbol given in BS 3510" in the first paragraph, with "radiation warning symbol given in The Radiation Protection Regulations 1982 or F8/AS1".

Clause 13.1 Replace the words "British Standards Institution" in the first paragraph with "Standards Association of New Zealand".

Clause 13.2 Replace the reference to "BS 4218" with "NZS 4231".

Figure 1 Delete.

3.5.5 Lighting supply

The lighting installation providing illumination to exit signs shall comply with NZBC G9 "Electricity". In particular, where an alternative supply provides the illumination for exit signs during interruption of the normal lighting supply, that installation shall comply with NZS 6742 as modified in F6/AS1".

COMMENT:

In the event of failure of the normal lighting, the visibility of the exit signs shall be maintained by illumination (internal or external) powered by an alternative supply. In most cases this illumination will be provided by the same fittings that provide the 'Lighting for emergency' (refer NZBC F6), but this is not necessarily the case. When separate fittings are used, the details of the installation are to meet the requirements of NZBC F6 in respect of duration and protection from *fire* damage.

4.0 Fire Related Safety Features

4.1 Call points

4.1.1 Call points shall be positioned in accordance with NZBC F7 “Warning Systems”.

4.1.2 Signs as shown in Figure 4 shall be provided on or adjacent to each call point. The method of operation, and the telephone number of the local fire brigade, shall be inserted in the spaces provided.

4.1.3 The sign colours shall be white and *safety red*.



4.2 Fire and smoke control doors

4.2.1 Fire doors and smoke control doors shall be provided as required by NZBC C3 “Spread of Fire”.

4.2.2 Every doorset required to possess fire or smoke stopping capabilities, shall have a sign fixed to both sides of the door leaf adjacent to the handle or push plate, stating “Fire Door, Please Keep Closed” or “Smoke Control Door, Please Keep Closed”, except that door leaves fitted with hold open devices shall have a sign stating only “Fire Door” or “Smoke Control Door”.

4.2.3 The sign shall measure no less than 90 mm x 50 mm and shall be in white letters no less than 8 mm high on a *safety green* background.

5.0 Access and Facilities for People with Disabilities

5.0.1 Signs shall be provided to:

- a) Identify *accessible routes*, and
- b) Identify facilities provided specifically for *people with disabilities*. Such facilities are:
 - Reserved car parking
 - Accessible entrance
 - Services available in the *building*
 - Accessible routes through the *building*
 - Toilet facilities

5.0.2 All signs (except as required by Paragraph 5.0.3) shall:

- a) Display the symbol of access, and as appropriate, include the direction of travel and name of the facility (see Figure 5),
- b) Use lettering and symbols in a colour which contrasts clearly with the sign background, and
- c) Use the proportional layout of the symbol of access, as shown in Figure 6.

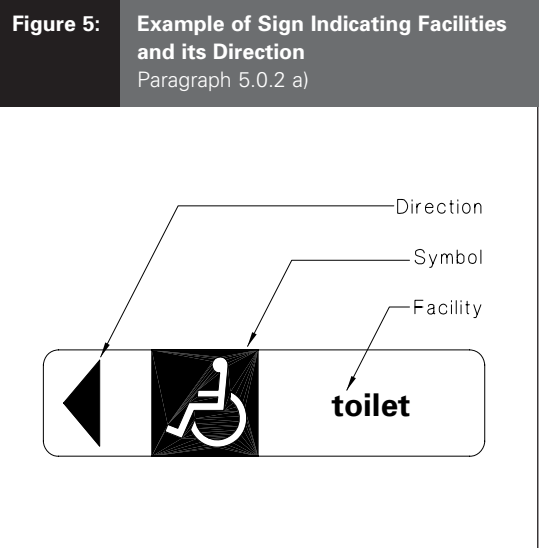

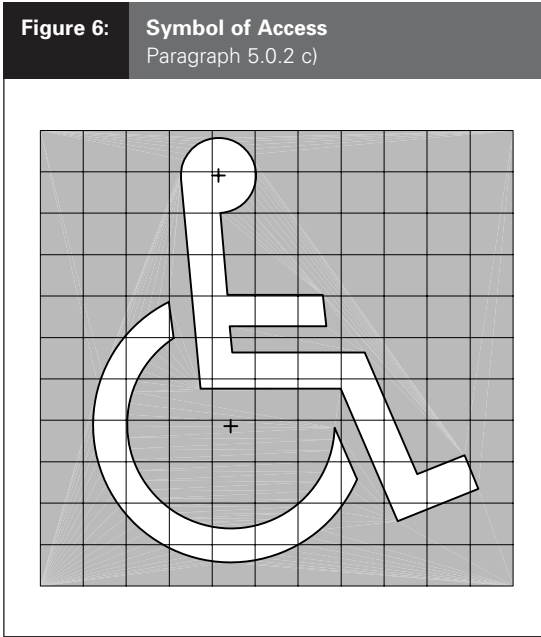

5.0.3 Where a listening system is installed, a sign displaying the international symbol for deafness, as shown in Figure 7, shall be provided at the main door(s) to the *building* and the room.

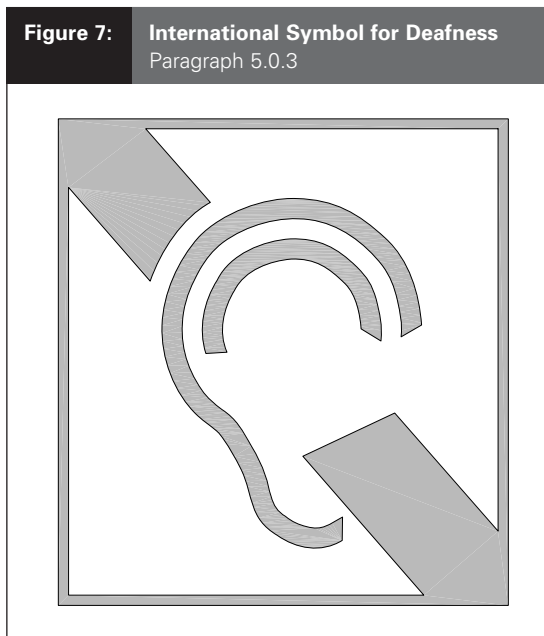

6.0 Potential Hazards

6.1 Dangerous goods

6.1.1 Classes of *dangerous goods* given here are as described in Appendix A of F3/AS1.

6.1.2 Signs warning of *dangerous goods* shall comply with the requirements for caution signs (see Paragraph 2.2.2).

6.1.3 Alternatively, signs conforming with Paragraph 6.1.4 may be used. Except as noted otherwise, they shall have text in *safety red* on a white background, and lettering height complying with Table 4.

6.1.4 The text and location of signs shall conform with the following requirements according to the class of *dangerous goods*.

COMMENT:

Signs having similar wording but conveying the same message may also be acceptable.

Class 1

Buildings storing explosives shall be provided with a sign at the entrance saying "EXPLOSIVES - CAUTION".

Class 2

- a) At places storing Class 2(b) *dangerous goods* there shall be displayed at the entrance a sign bearing the words "FLAMMABLE GAS AREA – NO SMOKING".
- b) Any room or chamber where any flammable gas of Class 2(b) which forms an explosive mixture with air is discharged, shall have a warning notice bearing the words "FLAMMABLE GAS AREA – NO SMOKING" located at its entrance.
- c) Rooms storing more than the equivalent of 60 m³ of acetylene, measured at a temperature of 15°C and a pressure of 1 atmosphere, inside any *building* shall display at the entrance to the room, a warning notice bearing the words "ACETYLENE – NO SMOKING OR OPEN FLAMES".

- d) Vehicle refuelling stations for dispensing *dangerous goods* of Class 2(d) shall display a notice reading "FLAMMABLE GAS – NO SMOKING – STOP YOUR ENGINE – APPLY HANDBRAKE".
- e) Filling stations, for filling cylinders having a capacity of no more than 5 kg with *dangerous goods* of Class 2(d) shall display a warning notice reading "FLAMMABLE GAS AREA – NO SMOKING OR OPEN FLAMES".
- f) Spaces storing Class 2(d) *dangerous goods* shall display a notice bearing the words "FLAMMABLE GAS AREA – NO SMOKING".
- g) Spaces storing Class 2(g) *dangerous goods* in bulk (i.e. in receptacles of liquid capacity greater than 250 litres) shall display at the entrance a notice bearing the name of the gas followed by the warning – "NO SMOKING OR OPEN FLAMES".

Class 3

- a) Spaces storing Class 3(a) or Class 3(b) *dangerous goods* other than in bulk, (i.e. in receptacles of less than 250 litres capacity), shall display at the entrance a warning notice bearing the words "FLAMMABLE LIQUIDS STORE – NO SMOKING".
- b) Every entrance to a *dangerous goods* *workroom* or *building* using Class 3(a) or Class 3(b) *dangerous goods* shall display a warning notice bearing the words "FLAMMABLE LIQUIDS AREA – NO SMOKING".

Class 5

Buildings storing Class 5(b) *dangerous goods* in quantities exceeding 25 kg shall display at the entrance the warning "FLAMMABLE ORGANIC PEROXIDES – NO SMOKING".

Class 7

- a) Any place storing radioactive material shall display a warning sign at each entrance or other point of access. The sign (see Figure 8) shall bear the radiation warning symbol with an overall diameter of at least 100 mm. Its colour is to be black, magenta, or purple on a yellow background. The sign

shall bear the words "CAUTION – RADIOACTIVE MATERIAL" in letters at least 8.0 mm high.

However, signs are not required if the radioactive material is *adequately* protected against unauthorised removal, and is:

- i) packed and labelled in accordance with the International Atomic Energy Agency Transport Regulations, or
 - ii) held temporarily in containers labelled in accordance with Clause 3 of the Second Schedule to the Radiation Protection Regulations 1982.
- b) Any place using radioactive material, or any irradiating apparatus in a *controlled area*, shall display a warning sign at each entrance or other point of access. The sign shall be as described in a) above, except that the text shall read "CAUTION – CONTROLLED AREA", and in addition bears the words "ENTRY PROHIBITED EXCEPT WITH THE AUTHORITY OF (name of *licensee*/Radiation Safety Officer). All letters shall be at least 8.0 mm high.

Figure 8: Radiation Warning Symbol
Paragraph 6.1.4 (Class 7)

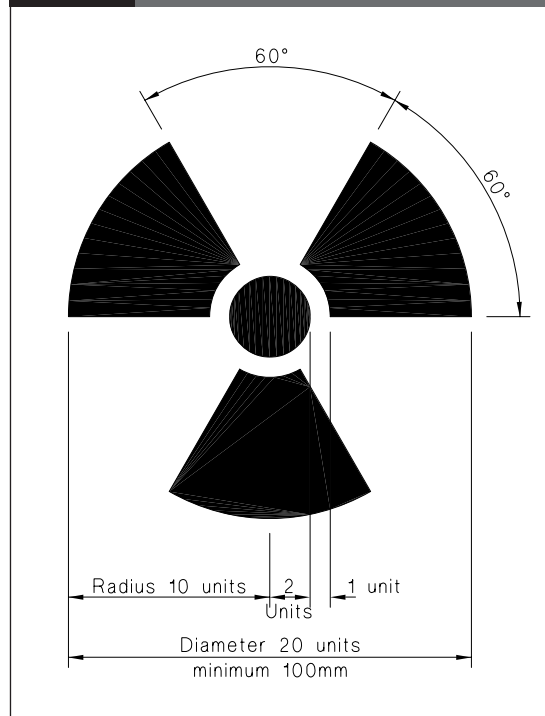

6.2 Electrical hazards

6.2.1 Bare *active conductors* that are exposed shall be indentified:

- a) At each termination,
- b) At intervals of no more than 15 m, and
- c) In each room through which they pass.

6.2.2 The caution *safety sign* shall comply with Figure 9 and Paragraph 2.2.2.

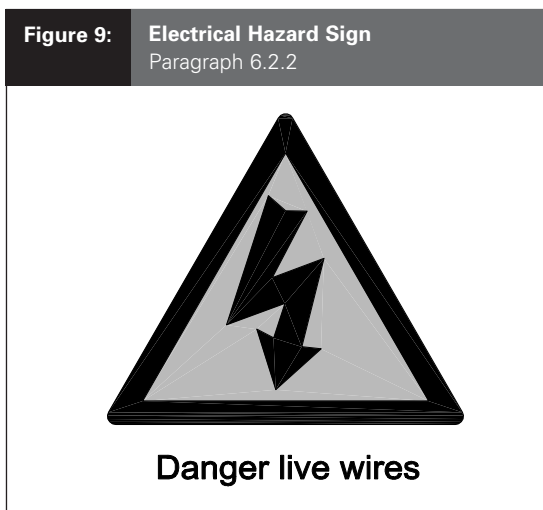

6.3 Floor loadings

6.3.1 Buildings

- a) In all workrooms, workshops, factories, warehouses, stores and garages the design live load appropriate to each section of the floor shall be displayed on a sign placed in a conspicuous position.

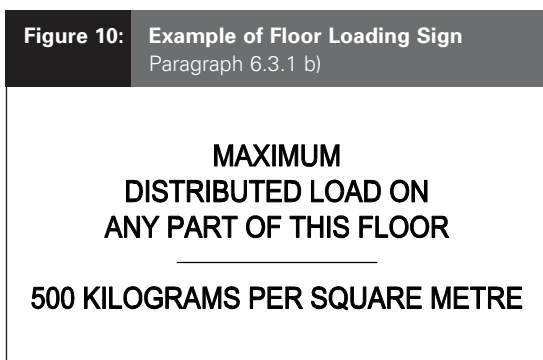

- b) The sign shall be no less than 900 mm above the floor, 230 mm long and 100 mm wide, and worded as shown in Figure 10 with letters at least 8.0 mm high.

6.3.2 Lifts

a) **Passenger lifts**

A sign shall be fitted to each lift car and display, in lettering at least 6.0 mm high, the lift’s rated load in persons and kilograms.

b) **Service lifts**

A sign shall be fitted at each landing and display in lettering at least 6.0 mm high, the contract load in kilograms.

COMMENT:

It is recommended that signs required by Paragraph 6.3 be *safety red* on a white background.

6.4 Fire safety

6.4.1 Lifts

A sign shall be provided on or adjacent to each landing call button plate. In letters at least 8.0 mm high it shall read “DO NOT USE LIFT IN EVENT OF FIRE” or “IN EVENT OF FIRE - DO NOT USE LIFT”.

COMMENT:

It is recommended that signs required by Paragraph 6.4.1 be *safety red* on a white background.

6.4.2 Sprinklered buildings

- a) Where storage heights could exceed those for which the sprinkler system has been designed, warning signs shall be provided.
- b) Signs shall be positioned so that the bottom of the sign is at the highest level to which storage is permitted.
- c) Signs shall be visible from 90% of all locations within aisles.
- d) The sign shall comprise lettering, arrows and 45° lines in *safety red* on a white background and be sized as shown in Figure 11.

Amend 1
Sep 1993

COMMENT:

The height limitation of 4.0 m shown in Figure 11 is an example only. In use the actual height limitation appropriate to the situation will be shown.

6.4.3 Use of stairs by fire service personnel

- a) Stairs used by fire service personnel shall be provided with signs to identify the floor level. The sign shall be clearly visible from each floor level landing.
- b) Where fire hydrants are located inside spaces containing a *stairway*, stair doors which give access to those hydrants shall be identified. This requirement applies only to those doors located on floors to which fire service personnel have direct access from the street and where more than one stair leads away from those floors. An acceptable sign is shown in Figure 12.
- c) Where fire hydrants are located in spaces containing scissor stairs, the *stairway* doors at each level providing direct access from the street for fire service personnel shall display a sign indicating the floor level location of hydrants which can be accessed from that particular door. An acceptable sign is shown in Figure 13.
- d) Signs required by Paragraph 6.4.3 shall comply with Paragraph 1.0 and have lettering of no less than 25 mm in height. Signs required by Paragraphs 6.4.3 b) and 6.4.3 c) shall comprise white lettering on a safety red background.

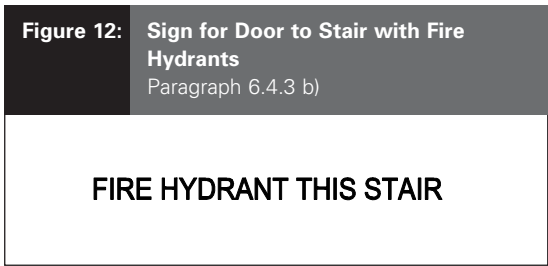

Amend 1
Sep 1993

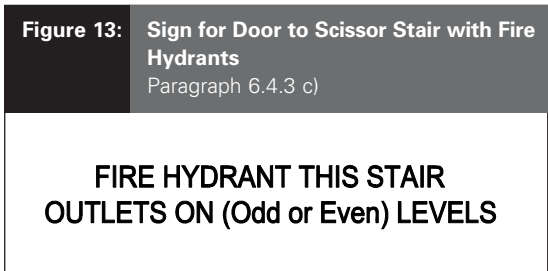

Amend 1
Sep 1993

6.5 Machine rooms

6.5.1 The sign shown in Figure 14 shall be provided adjacent to every lift and escalator machine room door.

Amend 1
Sep 1993

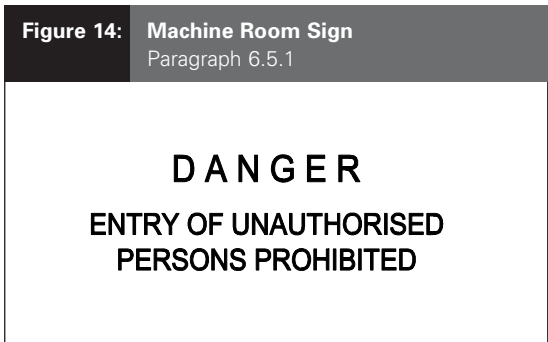

Amend 1
Sep 1993

6.5.2 The word DANGER shall be printed in 50 mm high letters, and the remainder of the notice in letters at least 25 mm high.

6.5.3 The sign shall be placed where it is not obscured when the door is in the open position.

COMMENT:

It is recommended that signs required by Paragraph 6.5 be *safety red* on a white background.

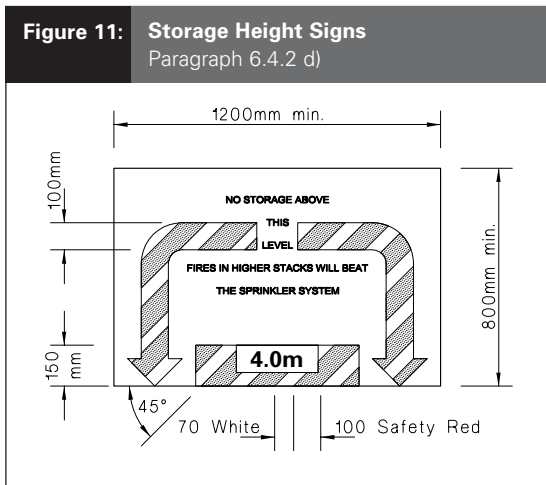

Amend 1
Sep 1993

Amend 1
Sep 1993

Amend 1
Sep 1993

Figure 15: Diagrams for Escalators and Moving Walks
Paragraph 6.6

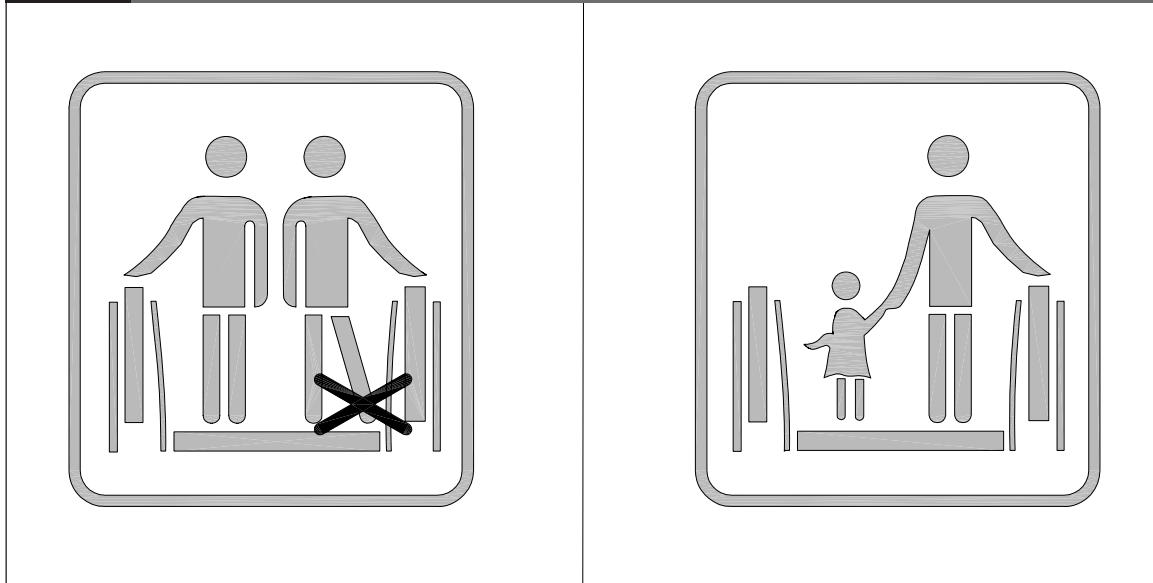

6.6 Escalators and moving walks

6.6.1 Signs shall be displayed at the entrance to escalators and moving walks.

6.6.2 If the signs comprise words only, they shall contain the following instructions, where appropriate, in letters at least 8.0 mm high:

- a) Small children must be firmly held by adults,
- b) Hold the *handrail*,
- c) Stand facing the direction of travel,
- d) Keep feet away from sides.

6.6.3 If diagrams are used they shall be as shown in Figure 15 with a minimum size of 80 mm x 80 mm and colours of blue on a white background, with the cross (X) in red.

Amend 1
Sep 1993

6.7 Water supplies

6.7.1 Outlets of non-potable water shall be identified as not being suitable for drinking, by using the prohibition *safety sign* shown in Figure 16.

Amend 1
Sep 1993

Figure 16: Non-potable Water Sign
Paragraph 6.7.1

Amend 1
Sep 1993



Index F8/VM1 & AS1

All references to Verification Methods and Acceptable Solutions are preceded by **VM** or **AS** respectively.

Escape routes	AS1 3.0
exitways	AS1 3.1.1 a) b) c), 3.2.3 a) b)
final exits	AS1 3.1.1 a) b), 3.2.3 a)
open paths	AS1 3.1.1 a)
safe paths	AS1 3.2.3 b)

People with disabilities	AS1 5.0
access route identification	AS1 5.0.1 a) b)
facility identification	AS1 5.0.1 b)
listening system identification	AS1 5.0.3, Figure 7

Signs

exit signs	AS1 3.0
alternative exit signs	AS1 3.2.3 b)
arrows	AS1 3.2.2, 3.3.2, Figure 3
backgrounds	AS1 3.3.3
colours	AS1 2.1, 3.4, 3.5.3 a) b), 4.1.3, Table 3
illumination	AS1 3.5
externally illuminated	AS1 3.5.2
internally illuminated	AS1 3.5.3
lighting supply	AS1 3.5.5
self-luminous	AS1 3.5.4
lettering	AS1 3.3.1, Table 4
location	AS1 3.1
no exit signs	AS1 3.2.3 a)
wording	AS1 3.2
fire safety signs	AS1 4.0, 6.4
call points	AS1 4.1, Figure 4
colours	AS1 4.1.3
fire and smoke control doors	AS1 4.2
lifts	AS1 6.4.1
stairs for Fire Service personnel	AS1 6.4.3, Figures 12 and 13
storage heights	AS1 6.4.2, Figure 11
hazard signs	AS1 6.0
dangerous goods	AS1 6.1
class 1	AS1 6.1.4
class 2	AS1 6.1.4
class 3	AS1 6.1.4
class 5	AS1 6.1.4
class 7	AS1 6.1.4
colour	AS1 6.1.3, 6.1.4
radiation warning symbol	AS1 6.1.4, Figure 8
colour	AS1 6.1.3
layout	AS1 6.1.3
lettering	AS1 6.1.3, 6.1.4
location	AS1 6.1.4

Amend 1
Sep 1993

Signs (continued)

	electrical hazards	AS1 6.2, Figure 9
Amend 1 Sep 1993	escalators and moving walks	AS1 6.6, Figure 15
	floor loadings	AS1 6.3
	buildings	AS1 6.3.1, Figure 10
	lifts	AS1 6.3.2
	passenger lifts	AS1 6.3.2 a)
	service lifts	AS1 6.3.2 b)
	lettering type and proportions	AS1 1.0, Table 1
Amend 1 Sep 1993	machine rooms	AS1 6.5, Figure 14
	non-potable water	AS1 6.7, Figure 16
	people with disabilities signs	AS1 5.0
	access symbol	AS1 5.0.2 c), Figure 6
	layout	AS1 5.0.2 Figure 5
	listening systems	AS1 5.0.3, Figure 7
	safety signs	AS1 2.0, 3.2.1
	caution signs	AS1 2.2.2, 6.1.2, 6.2.2, Figure 2
	colours	AS1 2.1, Table 3
	layout	AS1 2.2
Amend 1 Sep 1993	prohibition and stop signs	AS1 2.2.1, 6.7.1, Figure 1
	safe condition signs	AS1 2.2.3
	safety symbols	AS1 2.3