

**Structural Performance
of
Christchurch CBD Buildings
in the
22 February 2011 Aftershock**

Stage 1 Expert Panel Report

covering:

**Pyne Gould Corporation Building
Hotel Grand Chancellor Building
Forsyth Barr Building**

30 September 2011

*Report of an Expert Panel
appointed by the
New Zealand Department of Building and Housing*

Table of Contents

1.0	Introduction	3
2.0	Objective/Scope/Terms of Reference.....	5
2.1.	Objectives	5
2.2.	Scope.....	5
2.3.	Terms of Reference	7
3.0	Approach	9
3.1.	Expert Panel	9
3.2.	Consultant appointments / scope of activities	11
3.3.	Department management and support.....	12
3.4.	Information from other parties.....	12
3.5.	Review of report material by selected parties.....	12
3.6.	Contact with Canterbury Earthquakes Royal Commission of Inquiry.....	13
3.7.	Consultant reports.....	13
3.8.	Site and materials investigations	13
4.0	Context.....	14
4.1.	Earthquake events	14
4.2.	Impacts of 22 February 2011 aftershock	15
4.3.	Ground shaking and building response	17
5.0	Pyne Gould Corporation Building	24
5.1.	Summary.....	24
5.2.	Investigation.....	24
5.3.	Building description.....	25
5.4.	Structural modifications	27
5.5.	Design basis and code compliance	27
5.6.	Geotechnical.....	27
5.7.	Seismological.....	27
5.8.	Effects of 4 September 2010 earthquake and 26 December 2010 aftershock	28
5.9.	Effects of 22 February 2011 event.....	28
5.10.	Probable reasons for collapse	28
5.11.	Conclusions	28
5.12.	Recommendations	31
6.0	Hotel Grand Chancellor Building.....	32
6.1.	Summary.....	32
6.2.	Investigation.....	32
6.3.	Building description.....	33
6.4.	Structural modifications	34
6.5.	Design basis and code compliance	34
6.6.	Geotechnical.....	34
6.7.	Effects of 4 September 2010 earthquake and 26 December 2010 aftershock	35
6.8.	Effects of 22 February 2011 event.....	35
6.9.	Probable reasons for structural failure.....	36
6.10.	Conclusions	38
6.11.	Recommendations	38

7.0	Forsyth Barr Building.....	40
7.1.	Summary	40
7.2.	Investigation.....	40
7.3.	Building description	41
7.4.	Structural modifications	43
7.5.	Design basis and code compliance	43
7.6.	Geotechnical.....	43
7.7.	Effects of 4 September 2010 earthquake and 26 December 2010 aftershock	43
7.8.	Effects of 22 February 2011 event	44
7.9.	Mode of collapse	45
7.10.	Probable reasons for collapse.....	47
7.11.	Conclusions	47
7.12.	Recommendations.....	48
8.0	Principal Findings and Recommendations	49
8.1.	Introduction	49
8.2.	Findings	49
8.3.	Priority recommendations.....	50
8.4.	Other recommendations	51
	List of Report Appendices.....	53
	Appendix A. Panel Members' Biographies	54
	Appendix B. Information Obtained	57
	Appendix C. Glossary of terms.....	60

List of Appendices (Separate Volumes):

- PGC 1. Pyne Gould Corporation Building Consultant Report**
- HGC 1. Hotel Grand Chancellor Consultant Report**
- FB 1. Forsyth Barr Building Consultant Report**

1.0 Introduction

The Magnitude 7.1 Darfield earthquake on 4 September 2010 caused extensive damage to buildings and infrastructure in the Canterbury region including areas of Christchurch city and suburbs. Although damage was significant and widespread, there were no major building collapses and no loss of life. The impact on modern building structures was low. The Magnitude 4.9 aftershock on 26 December 2010 caused further damage.

On 22 February 2011 a Magnitude 6.3 aftershock centred near Lyttelton caused severe damage to Christchurch, particularly the Central Business District (CBD), eastern and southern suburbs, the Port Hills, and Lyttelton. Ground shaking intensities in Christchurch city, both horizontal and vertical, were in excess of those used as a basis for building design at any time up to the present day. As a result of the aftershock on 22 February 2011, 182 people died and many more were seriously injured. Many masonry buildings or parts of buildings collapsed in the CBD and many modern building structures were critically damaged. At least two multi-storey buildings collapsed and stairs collapsed in several modern multi-storey buildings.

The New Zealand Government, through its Department of Building and Housing, responded to public concern about damage to major buildings and identified for investigation four large multi-storey buildings in the Christchurch CBD which failed during the 22 February 2011 aftershock. The buildings included in the investigation are the Canterbury Television Building (CTV), the Forsyth Barr Building, the Hotel Grand Chancellor and the Pyne Gould Corporation Building (PGC). Two of these buildings experienced collapse and the other two experienced significant failure of building components, including stairs, columns and walls. Damage to these buildings is representative of many of the structural engineering effects that the earthquake and aftershocks have caused on commercial buildings in Christchurch.

This stage 1 report covers the PGC, Hotel Grand Chancellor and Forsyth Barr buildings for which investigations have been completed. A second report will be issued covering all four buildings once the CTV building report is completed. Further analyses have been found to be necessary for the CTV building in order to develop a full understanding of its behaviour in the 22 February 2011 aftershock, and the role of identified vulnerabilities in the collapse.

This report details the findings of the investigation on the three buildings, including the reasons for the building failures, key technical issues found and recommendations to the Department and the Government on changes needed in codes, standards, design and/or construction practices necessary to achieve adequate levels of safety in major earthquakes in New Zealand.

The results of the investigations conducted on these buildings assisted the Panel in making recommendations for future design and construction of buildings in areas prone to seismic activity.

Chapter 2 in this report outlines the objectives, scope and terms of reference for these investigations, while Chapter 3 describes the approach taken. Chapter 4 provides a contextual section outlining the general effects of the 22 February 2011 aftershock and the preceding 2010 earthquake and aftershock events.

Summaries of the investigations into the PGC, Hotel Grand Chancellor and Forsyth Barr buildings are provided in chapters 5, 6 and 7 of this report. The more detailed consultant reports on each building are contained in appendices as separate volumes (PGC 1., HGC 1. and FB 1.) to this report.

Chapter 8 presents the key findings of the investigations, highlights the important technical issues resulting from the investigations and gives recommendations aimed at improving future design and construction practice.

2.0 Objective/Scope/Terms of Reference

2.1. Objectives

The objectives of the investigation were to:

- determine the facts about the performance of four critical buildings in the Christchurch CBD during the 22 February 2011 aftershock, establishing the causes of, and factors contributing to, the building failures. This includes consideration of the effects of the 4 September 2010 earthquake and 26 December 2010 aftershock; and
- provide a comprehensive analysis of these causes and contributing factors, including, as context, the building standards and construction practices when these buildings were constructed or alterations were made to them.

2.2. Scope

The buildings identified to be investigated were:

- Pyne Gould Corporation Building at 233 Cambridge Terrace.
- Canterbury Television Building at 249 Madras St.
- Forsyth Barr Building at 764 Colombo St.
- Hotel Grand Chancellor at 161 Cashel St.

This stage 1 report covers only the PGC Building, Forsyth Barr Building and the Hotel Grand Chancellor Building.

Structural performance

The investigation has focused on the structural performance of each building and on any relevant factors which contributed to or may have contributed to the collapse of the building, or of its stairs where that occurred.

The investigation has reviewed and reported on:

- the original design and construction of the buildings, including the foundations and soils investigations
- the impact of any alterations and / or maintenance on the structural performance of the buildings
- estimation of the probable ground shaking at the building sites
- any structural assessments and reports made on the buildings, including those made during the emergency period following the 4 September 2010 earthquake

- the structural performance of the buildings in the 4 September 2010 earthquake and the 26 December 2010 aftershock, and in particular the impact on components that failed in the 22 February 2011 aftershock
- any further structural assessments and reports on the stability/safety of the buildings following the 4 September 2010 earthquake or the 26 December 2010 aftershock
- the cause(s) of the collapse of the buildings.

The investigation has also considered:

- the design codes, construction methods, and building controls in force at the time the buildings were designed and constructed and changes over time as they applied to these buildings
- knowledge of the seismic hazard and ground conditions when these buildings were designed
- changes over time to knowledge in these areas
- any policies or requirements of any agency to upgrade the structural performance of the buildings.

Clarification of Codes and Standards

There may be some confusion with references made to the Building Code, the Code, codes, standards and/or Standards. All of these terms refer to elements of the building controls regime as it affects the design and construction of buildings. The current system under the Building Act 2004 is as follows:

- *Building Code (or the Code), using capital letters, refers to the New Zealand Building Code. This is a high-level performance-based document that defines the overall objectives, functional requirements and performance requirements for buildings. The Building Code covers safety, health, well-being and sustainability. Structural requirements are contained in Clause B1 of the Building Code.*
- *Compliance documents related to Clause B1 of the Building Code refer to certain New Zealand Standards. Compliance with the Standards (note capital 'S') cited in Clause B1 is deemed to be compliance with the relevant provisions of the performance requirements of the Building Code.*
- *Compliance with the Building Code thus implies compliance with relevant Standards, such as those for earthquake actions, concrete structural design and so on. This is often loosely referred to as compliance with the code or with standards.*

This building controls regime has been in place in New Zealand since 1991. Before that date, more prescriptive requirements were defined in legislation and New Zealand Standard Specifications.

In general terms, in this report, reference to compliance with the code means that the structural design (or construction) was in accordance with the relevant requirements of the building controls regime at the time.

Each investigation used available records of building design and construction, and invited and obtained evidence in the form of photographs, video recordings and first-hand accounts of the state or performance of the buildings prior to, during and after the 22 February 2011 aftershock.

2.3. Terms of Reference

The Terms of Reference for the Department's investigation are shown in the table on the following page.

The investigation timelines as detailed in the Terms of Reference were extended. This was necessary to allow for delays in gaining access to sites to complete the necessary forensic investigations; to identify and interview witnesses; to examine the effects of the 4 September 2010 earthquake, 26 December 2010 aftershock and 22 February 2011 aftershock; to analyse a range of potential failure mechanisms, and to allow for comments by selected parties.

Matters outside the scope of the investigation

The investigations and reports have established, where possible, the likely cause or causes of building failures. They did not, and were not intended to address issues of culpability or liability. These matters were outside the scope of the investigation. To be consistent with this and to focus on the issues raised in the investigation, the Panel decided not to use the names of the parties professionally associated with the buildings. This has been applied throughout the investigation documents.

Terms of Reference for the Department's investigation

Technical Investigation into the Performance of Buildings in the Christchurch CBD in the 22 February 2011 Christchurch Aftershock

Terms of Reference

The Canterbury region suffered a severe earthquake on 4 September 2010 and an aftershock on Boxing Day. This was followed by another, more damaging aftershock on 22 February 2011. The Magnitude 6.3 aftershock on 22 February 2011 caused significant damage to Christchurch, particularly the CBD, eastern, and southern suburbs, the Port Hills, and Lyttelton.

The high intensity of ground shaking led to a number of collapsed or seriously damaged buildings and a large number of people killed or seriously injured. It is important for New Zealanders that the reasons for the damage to buildings generally in the CBD, and to some particular buildings, are definitively established.

Matters for investigation

The buildings specified for detailed analysis include the: Pyne Gould Corporation; CTV; Forsyth Barr and Hotel Grand Chancellor buildings. Others may be specified for detailed analysis as information comes to hand during the investigation.

The purpose of this technical investigation into the performance of buildings in the Christchurch CBD during the 22 February aftershock, is to establish and report on:

- the original design and construction of the buildings;
- the impact of any alterations to the buildings;
- how the buildings performed in the 4 September 2010 earthquake, and the Boxing Day aftershock, in particular the impact on the buildings;
- what assessments, including the issuing of green stickers and any further structural assessments, were made about the buildings' stability/safety following the 4 September 2010 earthquake, and the Boxing Day aftershock; and
- why these buildings collapsed or suffered serious damage.

The investigation will take into consideration:

- the design codes, construction methods, and building controls in force at the time the buildings were designed and constructed and changes over time as they applied to these buildings;
- knowledge that a competent structural / geotechnical engineer could reasonably be expected to have of the seismic hazard and ground conditions when these buildings were designed;
- changes over time to knowledge in these areas; and
- any policies or requirements of any agency to upgrade the structural performance of the buildings.

The investigation will use records of building design and construction, and will also obtain and invite evidence in the form of photographs, video recordings and first-hand accounts of the state or the performance, of the buildings prior to, during, and after the 22 February 2011 aftershock.

Matters outside the scope of the investigation

The investigation and report is to establish, where possible, the cause or causes of building failures. It is not intended to address issues of culpability or liability arising from the collapse of the building. These matters are outside the scope of the investigation.

Report required

The Department will prepare a detailed written report, setting out the conclusions drawn from this investigation about the matters referred to in the above section by 31 July 2011.

3.0 Approach

3.1. Expert Panel

Following a request from Government, the Department initiated the investigations by appointing professional engineering consultants for each building and a professional engineer to carry out initial forensic testing on three buildings. To oversee this work, the Department established a Panel of Experts and a Terms of Reference for the Expert Panel (Panel) as set out on the following page. The Department managed the work of the consultants and the Panel and provided additional resources to support the project including engineering, secretarial, legal, and communications personnel.

The Panel who have produced this report were appointed to provide guidance on the methodology of the investigations, to review and approve consultants' reports and to report on their implications. Panel members were chosen to provide a background of experience in the range of matters related to the planning, design, approval and construction of buildings.

This report is based on the findings and conclusions of the consultants engaged by the Department of Building and Housing. It was not the function of the Panel to undertake a full engineering peer review of those findings and conclusions.

Members of the Panel and authors of this report are:

- Sherwyn Williams (Chair), Consultant, Kensington Swan, Auckland, construction law expert.
- Professor Nigel Priestley, Emeritus Professor of Structural Engineering at the University of California, San Diego. (Deputy Chair). Specialist and leading authority on earthquake design of structures.
- Dr Helen Anderson, Consultant, former Chief Executive of the Ministry of Research, Science and Technology, specialist knowledge in seismology.
- Marshall Cook, Architect, past Adjunct Professor of Design at Unitec, Auckland. Specialist knowledge of building design for earthquakes.
- Peter Fehl, Director Property Services, University of Auckland, Auckland, specialist knowledge of construction and construction industry practice.
- Dr Clark Hyland, Hyland Consultants, Auckland, specialist forensic and earthquake engineer.
- Rob Jury, Technical Director-Structural Engineering, Beca, Wellington, specialist structural design engineer.
- Peter Millar, Tonkin and Taylor, Auckland, specialist knowledge of geotechnical engineering practice.
- Professor Stefano Pampanin, Associate Professor at the College of Engineering, University of Canterbury, Christchurch. Specialist and leading authority on earthquake design of structures.
- George Skimming, Director Special Projects at Wellington City Council, Wellington, specialist knowledge of Territorial Authority roles in building procurement.

- Adam Thornton, Director, Dunning Thornton, Wellington, specialist structural design engineer.

Brief biographies of Panel members are given in Appendix A.

Particular roles and responsibilities of the Panel were as follows:

- Providing guidance and direction to the investigation.
- Advising on the scope and extent of investigation necessary to achieve the overall objectives of the investigation.
- Monitoring and reviewing the approaches, investigations, data and outputs of the consultants.
- Recommending to the Department any changes in the scope and nature of work necessary to address the matters for investigation fully, accurately and authoritatively.
- Reviewing and approving the consultants' reports on each building.
- Producing an overview report (including this report) addressing the matters for investigation and indicating any issues for further consideration by the Department in its role as the Regulator responsible for the Building Act and Building Code.

Terms of Reference for the Expert Panel

Technical Investigation into the Performance of Buildings in the Christchurch CBD in the 22 February Christchurch Aftershock

General

Overall Terms of Reference for the investigation are given in Attachment 1.

Investigations will look at the expected performance of the buildings, when they were built, the impact of any alterations, compliance with the code at the time, and the reasons for the collapse. The investigations will focus only on the technical findings and are not to address liability.

The Department of Building and Housing has overall responsibility for the outcome of the investigation and has appointed:

- *Engineering consultants to investigate the subject buildings*
- *A panel of experts to assist in achieving the overall objectives of the investigation*

These Terms of Reference for Expert Panel describe the roles and responsibilities of the expert panel in the context of the overall Terms of Reference for the investigation.

Outline Approach and Outputs

The main outputs of the investigation will be:

- *Consultant technical investigation reports on each building*
- *A report prepared by the Expert Panel to the Department*
- *A Department report to the Minister on the outcome of the investigation.*

The investigating consultants will be responsible for their own work and for determining the inputs they use to reach their conclusions. The consultant reports will be attachments to the Expert Panel Report.

The Department Report will be based on material in the consultant reports and the Expert Panel Report.

Roles and Responsibilities

The panel members have been chosen to provide a background of experience in the range of matters related to the planning, design, approval and construction of buildings.

In general, it is expected that, individually and collectively, panel members will help the Department to provide comprehensive, accurate and authoritative accounts of why the buildings collapsed and what the implications are for the Building Act and Code.

Particular roles and responsibilities include:

- *Providing guidance and direction to the investigation.*
- *Advising on the scope and extent of investigation necessary to achieve overall objectives.*
- *Monitoring and reviewing the approaches, investigations, data and outputs of the engineering consultants.*
- *Recommending to the Department any changes in the scope and nature of work necessary to address the matters for investigation fully, accurately and authoritatively.*
- *Reviewing and approving the engineering consultant reports on each building.*
- *Producing an overview report addressing the matters for investigation and indicating any issues for further consideration by the Department in their role as regulator responsible for the Building Act and Code.*

Timeframe

The Department Report to the Minister is due by 31 July 2011. The Expert Panel Report is due by 30 June 2011. These deadlines may be revised if necessary for the investigation to achieve its objectives.

Conflicts of Interest

General

Panel members must declare all conflicts or potential conflicts of interest throughout the investigation. A register will be maintained which will be accessible to all members.

Interaction with engineering consultants

Panel members may provide comments to consultants in their role as panel members, but may not provide advice. Panel members are to advise other panel members of all such comments given as soon as possible.

Tonkin & Taylor may provide advice to consultants provided that Peter Millar is not personally involved.

3.2. Consultant appointments / scope of activities

The Department engaged New Zealand professional engineering consultants to carry out detailed investigations and structural analyses of each building.

The companies appointed were:

- CTV Building: Hyland Consultants / StructureSmith (Dr Clark Hyland, Ashley Smith)
- Forsyth Barr Building: Beca (Rob Jury, Dr Richard Sharpe)
- Hotel Grand Chancellor: Dunning Thornton (Adam Thornton, Alistair Cattanach)
- PGC Building: Beca (Rob Jury, Dr Richard Sharpe).

Dr Hyland, Rob Jury, and Adam Thornton were Panel members. Ashley Smith, Dr Richard Sharpe and Alistair Cattanach attended Panel meetings on occasion to present and discuss the investigations and their findings.

Panel members, individually and collectively, and through the work of the consultants, have helped to provide comprehensive and authoritative accounts of why the buildings collapsed or failed and what the implications are for the Building Act and Building Code.

3.3. Department management and support

Work of the Panel and the consultants was supported by Departmental representatives led by:

- David Kelly, Deputy Chief Executive, Building Quality
- Mike Stannard, Chief Engineer
- Dr David Hopkins, Senior Technical Advisor

Dr Hopkins, a specialist consultant in structural and earthquake engineering, managed the activities of the Panel and the consultants on behalf of the Department. He helped shape the technical content of the Panel and consultant reports and contributed to the technical discussions of the Panel.

The Department provided management, secretarial and editorial support, in addition to facilitating access to information to assist the Panel and the consultants. Vicky Newton was the Project Co-ordinator and Pam Johnston the Technical Writer for the Panel report.

3.4. Information from other parties

The Department invited evidence from members of the public and organisations involved or affected, who could supply photographs, video recordings and first-hand accounts of the state or performance of each building prior to, during, and after the 22 February 2011 aftershock.

A total of 34 people contacted the Department to provide evidence. All offers of evidence were passed onto the consultants who made further contact with those people where it was relevant to their investigations.

A number of people were identified to be interviewed. Interviews were conducted with building owners, people who worked on the buildings while being constructed, tenants of the buildings at the time of the earthquake and aftershock events, and witnesses who saw or experienced the collapse of buildings. Some interviews were conducted with the assistance of an experienced investigative interviewer resource from the Ministry of Social Development, and most were recorded and transcribed for ease of reference.

3.5. Review of report material by selected parties

The Panel gave considerable thought to allowing selected parties the opportunity to comment on the relevant consultant reports before public release. Those considered for referral included the owners, designers and builders, and the Christchurch City Council.

Without in any way addressing any questions of liability or culpability, it was decided to refer the relevant consultant reports to selected parties.

The parties to whom the reports were referred were asked to advise the Department of Building and Housing if they had any information that would cause the Panel to alter the

consultants' final reports. Comments received were considered in producing their final reports and this Panel report.

3.6. Contact with Canterbury Earthquakes Royal Commission of Inquiry

The Royal Commission was known to have a strong interest in the results of these investigations and common objectives in finding reasons and recommending changes. Contact was maintained with the Royal Commission and information of mutual interest was shared at key stages.

3.7. Consultant reports

The consultants gathered available information for their analyses of the buildings including:

- approved building consent drawings
- Christchurch City Council property files
- drawings, calculations and structural specifications supplied by the designers of the original buildings and any subsequent alterations
- how the buildings performed in the 4 September 2010 earthquake, in particular the impact of the earthquake on the buildings
- what assessments (including the issuing of green stickers and any further structural assessments) were made about the buildings' stability/safety following the 4 September 2010 earthquake
- media, police and USAR team photos
- interviews with building owners, those involved in the construction and design of the original buildings and subsequent alterations, tenants of the buildings and witnesses to the collapse of the buildings
- public evidence including accounts of the state of the buildings prior to the earthquake, opinions of those who had worked on or in the buildings and photos showing the state of the buildings prior to and after the earthquake and aftershocks.

3.8. Site and materials investigations

Investigations have included:

- site examinations to make initial observations on the nature of the failures
- retrieval of material samples for testing
- laboratory testing of the samples taken.

4.0 Context

4.1. Earthquake events

The Lyttelton earthquake event of 22 February 2011 was an aftershock of the Magnitude 7.1 Darfield (Canterbury) earthquake which occurred on Saturday 4 September 2010 at 4.35am. The Darfield event resulted in extensive areas of liquefaction, land damage and widespread damage to buildings and infrastructure in the Canterbury Region. The earthquake epicentre was approximately 35km west of the Christchurch central business district (CBD). Figure 4.1 shows the fault rupture associated with the 4 September 2010 earthquake (red line) and epicentre (green star). Other faults marked as dotted yellow lines are inferred from locations of aftershocks.

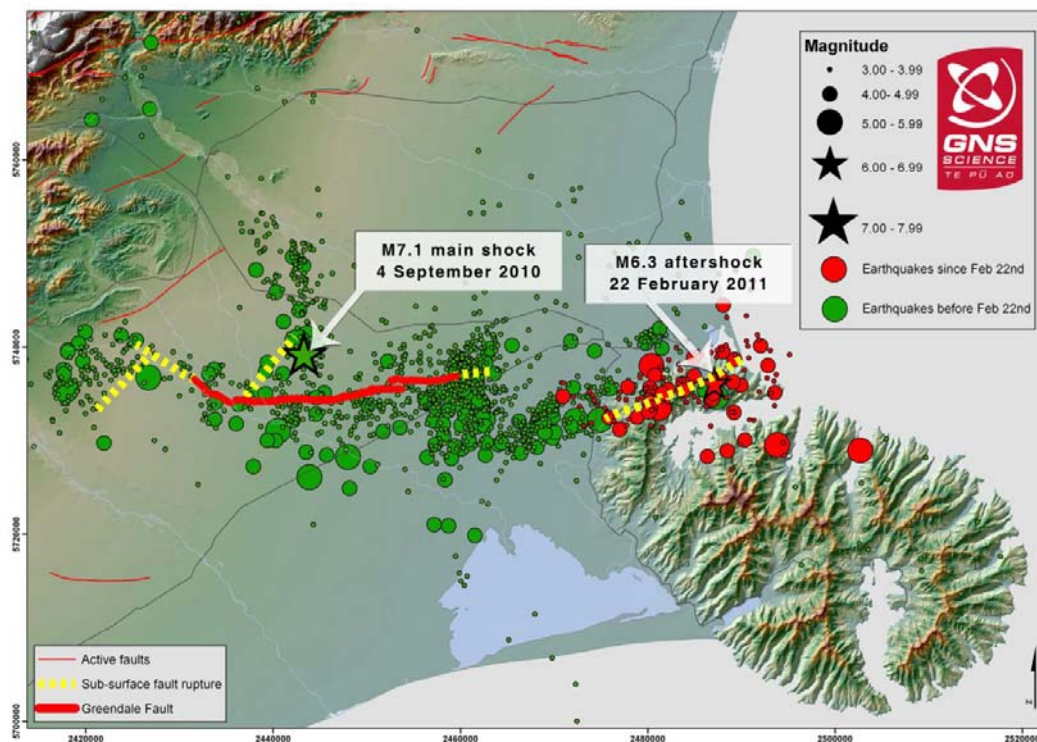

Figure 4.1: Fault rupture length and aftershock sequence for the 4 September 2010 and 22 February 2011 events. (Source: GNS)

While the impact of the Darfield earthquake was widespread and severe, there were no major building collapses and no loss of life. There was substantial damage to unreinforced masonry buildings (URM), largely in the CBD, but the time of the earthquake meant that few people were exposed to the hazard of falling masonry, which represented the bulk of building damage.

Several thousand aftershocks, including several Magnitude 5.0+ aftershocks, followed in the months after the 4 September 2010 earthquake, including the Magnitude 4.9 aftershock on 26 December 2010 that caused further damage in the CBD. The latter event was very close to

the CBD and produced significant ground shaking in Christchurch City despite the lower magnitude.

The Magnitude 6.3 Lyttelton aftershock occurred at 12.51pm on Tuesday 22 February 2011, approximately five months after the Magnitude 7.1 Darfield (Canterbury) earthquake. The epicentre of the 22 February 2011 event was approximately 10km south-east of the CBD, near Lyttelton, at a depth of approximately 5km. This is shown as a red star on Figure 4.1, which also shows the cluster of aftershocks since 22 February 2011.

4.2. Impacts of 22 February 2011 aftershock

Due to the proximity of the epicentre of the 22 February 2011 aftershock to the CBD, its shallow depth and peculiar directionality effects, very strong shaking was experienced in the city centre, the eastern suburbs, and the Lyttelton-Sumner-Port Hills areas. The shaking intensity of the 22 February 2011 aftershock recorded in the City of Christchurch was much greater than that of the main shock on 4 September 2010. The recorded values of peak vertical accelerations, in the range of 1.8g to 2.2g on the hills, were amongst the highest ever recorded worldwide.

Figures 4.2 (a) and (b) show a comparison of peak ground accelerations (both horizontal and vertical) recorded by the GeoNet Network in the CBD area for these two events.

On each map, the red vertical arrows represent the peak vertical accelerations and the blue horizontal arrows represent the peak horizontal accelerations. The acceleration scales are the same for both maps. The horizontal scale shows the peak acceleration regardless of its direction.

For the 22 February 2011 event, a wide range of (medium to very high) horizontal accelerations were recorded, with peaks exceeding 1.6 times gravity (1.6g) near the epicentre and between 0.4g and 0.7g in the CBD stations. This variation confirms strong dependence on the distance from the epicentre, and also reflects the site-specific soil characteristics.

In the CBD the highest values of peak ground vertical accelerations recorded were between 0.5g and 0.8g.

There are two points of particular note in the context of this investigation:

- The values of recorded accelerations for the 22 February 2011 event in the CBD are markedly greater than the comparable values on 4 September 2010.
- The values for the 22 February 2011 event reduce markedly and rapidly when moving to the west of the CBD.

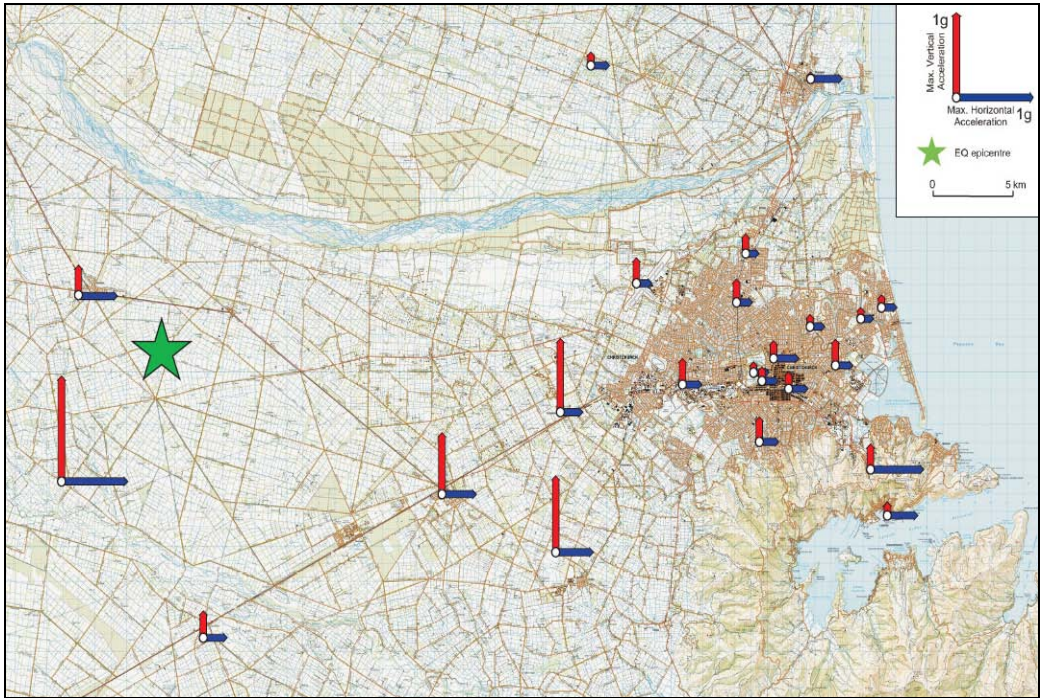

Figure 4.2 (a): Recorded peak ground accelerations – 4 September 2010

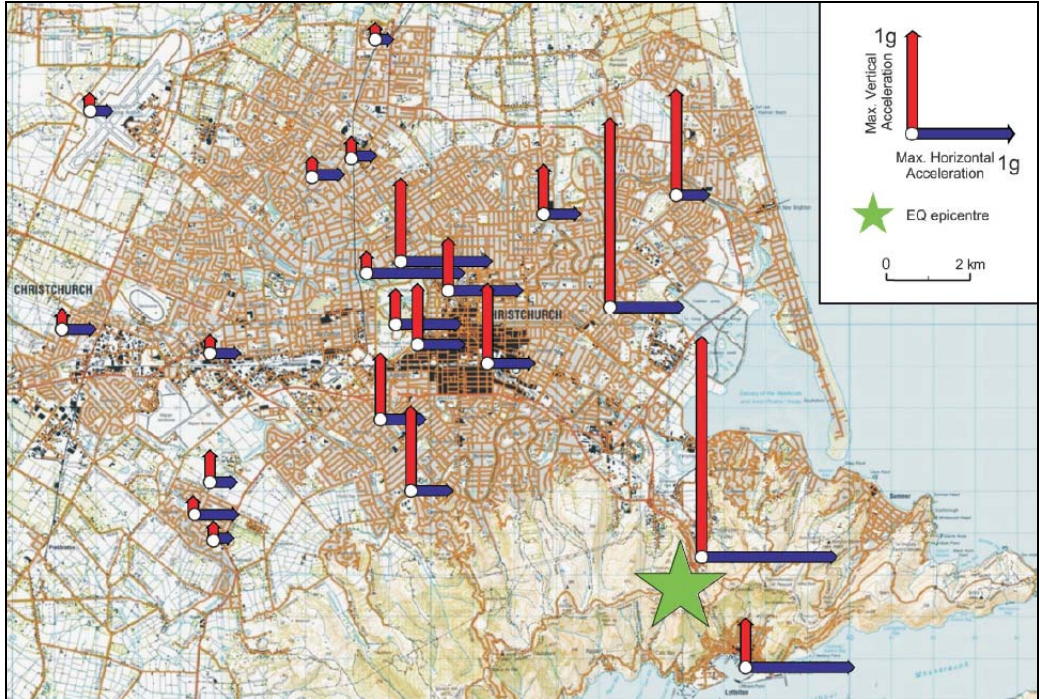

Figure 4.2 (b): Recorded peak ground accelerations – 22 February 2011

(Source: EQC-GNS GeoNet)

This event resulted in 182 fatalities, extensive damage and collapse of URM buildings, the collapse of two multi-storey buildings and widespread liquefaction affecting residential and commercial properties as shown in Figure 4.3. Most tall buildings in Christchurch are within the CBD, indicated by the yellow circle.

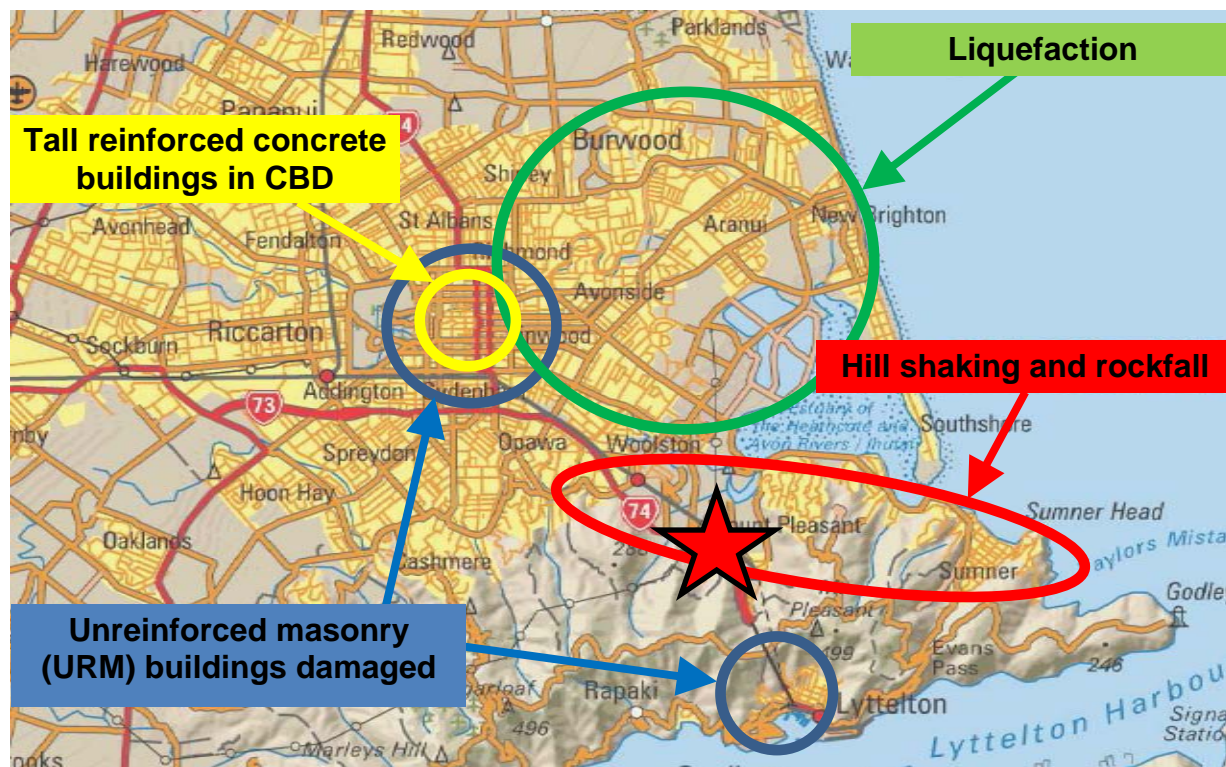

Figure 4.3: Overview of the impact of the 22 February 2011 Christchurch aftershock on the built environment.

(Source: NZCS/NZSEE/SESOC/TDS Series of Seminars)

4.3. Ground shaking and building response

4.3.1. General

Earthquake-resistant structural design over the past 50 years has sought to prevent the collapse of structures under strong earthquake shaking while recognising that damage, even irreparable structural damage, could occur in such conditions. Over recent years designers have sought to produce greater resilience in key structural members, especially columns and walls, and to control damage to the building fabric generally. Typically, buildings are designed to survive earthquake ground shaking intensities expected to occur, on average, not more than once every 500 years.

Damage to buildings, even those designed and built to the most recent standards, can be expected. Required standards are such that total collapse of a building, while it can never be ruled out, is not expected at ground shaking corresponding to the design level.

4.3.2. Response of buildings to the 4 September 2010 and 22 February 2011 earthquake events

Indications are that the ground shaking in the CBD on 22 February 2011 was sufficient to cause building responses at least comparable to, and in many cases exceeding, those used for the design of modern buildings. However, given the level of expected building response to ground shaking, and the continuous evolution of buildings codes in the past decades, it is not surprising that many of the multi-storey post-1960 buildings in the CBD suffered significant structural damage in the 22 February 2011 event.

Figures 4.4 (a) and (b) show plots of *spectral (building) acceleration* against *(building) period* for the 4 September and 22 February events.

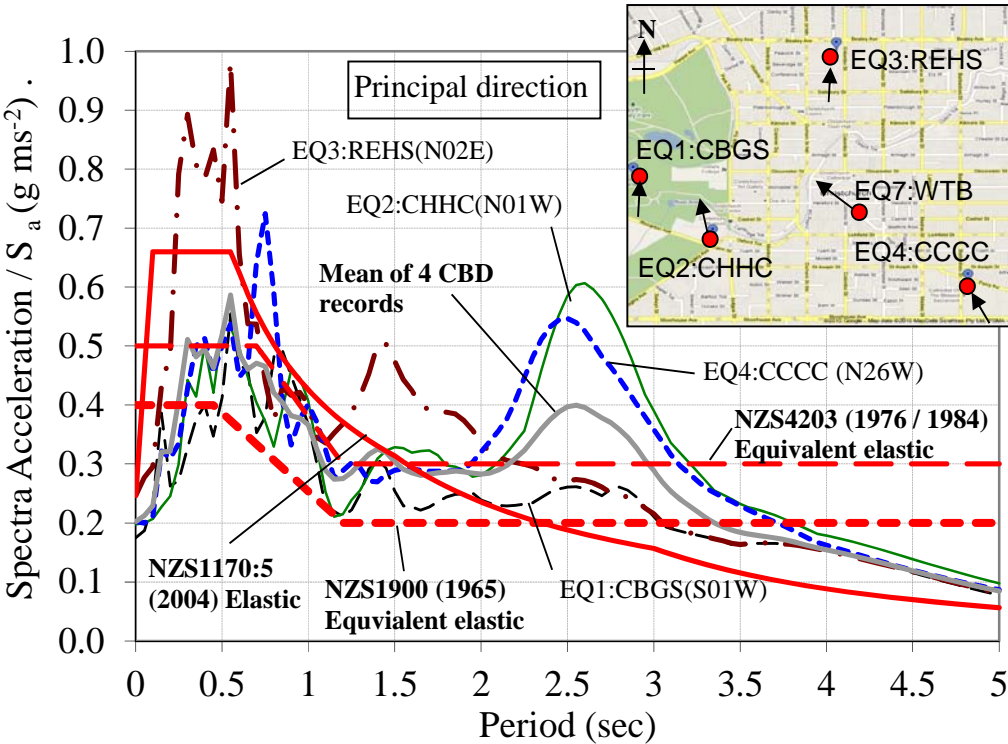

Figure 4.4 (a) Estimated acceleration response – 4 September 2010

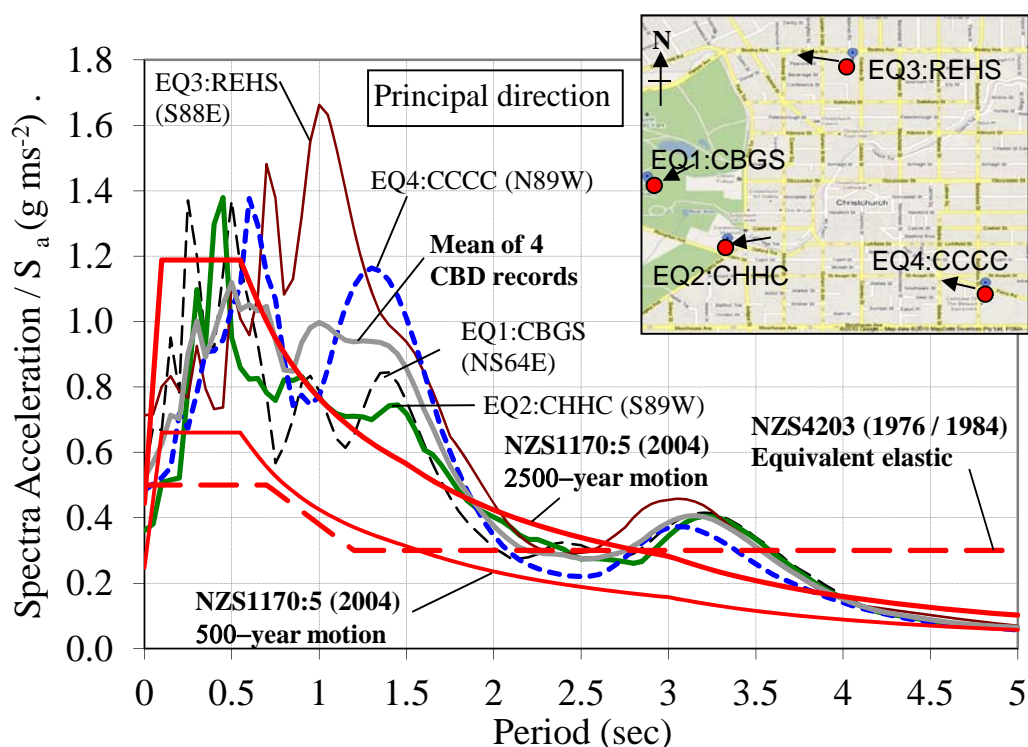

Figure 4.4 (b) Estimated acceleration response – 22 February 2011

The figures are taken from a contextual report prepared for the Department¹ and are reproduced here in order to illustrate the special challenges involved in estimating the response of any building to a particular earthquake.

These acceleration versus period plots are used by structural engineers to assess the likely earthquake response of buildings of different types and sizes. The vertical axis shows the (estimated) maximum acceleration of a building in response to specified ground motions. The horizontal axis shows the *period* (natural period of vibration) of a range of buildings. The period increases with the height of the building and varies with building type. Low height (stiffer) buildings have short periods. Taller buildings have longer periods. The estimated periods for the buildings in this investigation range from 0.7 for the PGC Building to 2.4 seconds for the Forsyth Barr Building.

The figures include estimated responses to measured ground accelerations at five different measurement stations, in or near the CBD. These values may be thought of as the structural 'demand' placed on buildings for a range of periods (heights / stiffnesses) as a result of the ground shaking. It can be seen that these demands vary greatly between one recording station and another and that they vary significantly with building period.

The red lines represent design levels used for Christchurch buildings in 2010, 1984 and 1976. The green line represents the 1965 standard. Comparison of design levels with the demand requires careful interpretation.

¹ Kam, W.Y., Pampanin, S., 2011 *General Performance of Buildings in Christchurch CBD after the 22 Feb 2011 Earthquake: a Contextual Report*, Department of Civil and Natural Resources Engineering, University of Canterbury, October.

4.3.3. Comparison with design levels

Figures 4.5 (a) and (b) are designed to provide a simple comparison between the demand on structures and their estimated capacity (at design level) for the September and the February events. Figures 4.4 (a) and (b) have been repeated in faded form. The overlaid lines show the comparisons in simplified terms.

The curved red line represents the 'design' level for most modern buildings in Christchurch – the 2004 standard. This curve is derived using a range of estimated ground accelerations of different types and then representing the responses as a single line. The line shown assumes that the structure responds elastically and does not yield. This makes it comparable with the demand curves derived from the ground motion records from the nominated stations. For design purposes ductile detailing is used and the acceleration values are reduced, typically by a factor of four. Importantly, such a reduction brings with it an obligation to detail the structural elements (beams, columns and walls) to achieve the level of ductility.

In a similar way, the other red line represents the design level for the 1984 and 1976 standards. Once again, these show the 'equivalent elastic' response values to be comparable with the ground motion response plots. Designs to these standards allow the accelerations to be reduced if ductility was provided in the design detailing.

For the 1976, 1984 and 2004 standards the 'equivalent elastic' curves represent the design performance level expected, because any reduction in the acceleration values used in design were compensated for by requirements for ductile detailing. This was not the case for the 1965 standard. Design accelerations used assumed that ductility was achieved, but there were no specific detailing requirements.

The green lines indicate design requirements for the 1965 standard. The upper green line represents a building designed to this standard in which full ductility is achieved. The lower green line represents a building designed to the 1965 standard in which no ductility is achieved. In fact, buildings designed to the 1965 standard will vary in levels of ductility achieved, so that the performance of a 1965 to 1976 building would be somewhere between the two green lines. The situation with any one building requires knowledge of its structural form and detailing.

It can be seen that buildings to the 1965 standard that achieve the higher levels of ductility plot significantly below the 1976 and 1984 standards, and well below current standards for periods up to 1.5 seconds. For taller (higher period) buildings the 1965, 1976 and 1984 standards are greater than the 2004 requirements.

In order to provide a comparison of the demand of the 22 February 2011 aftershock and the various design plots, the plots from the ground shaking records have been shown as a broad grey band on each figure. They are plotted as wide bands to indicate the variability evident between one recording station and another.

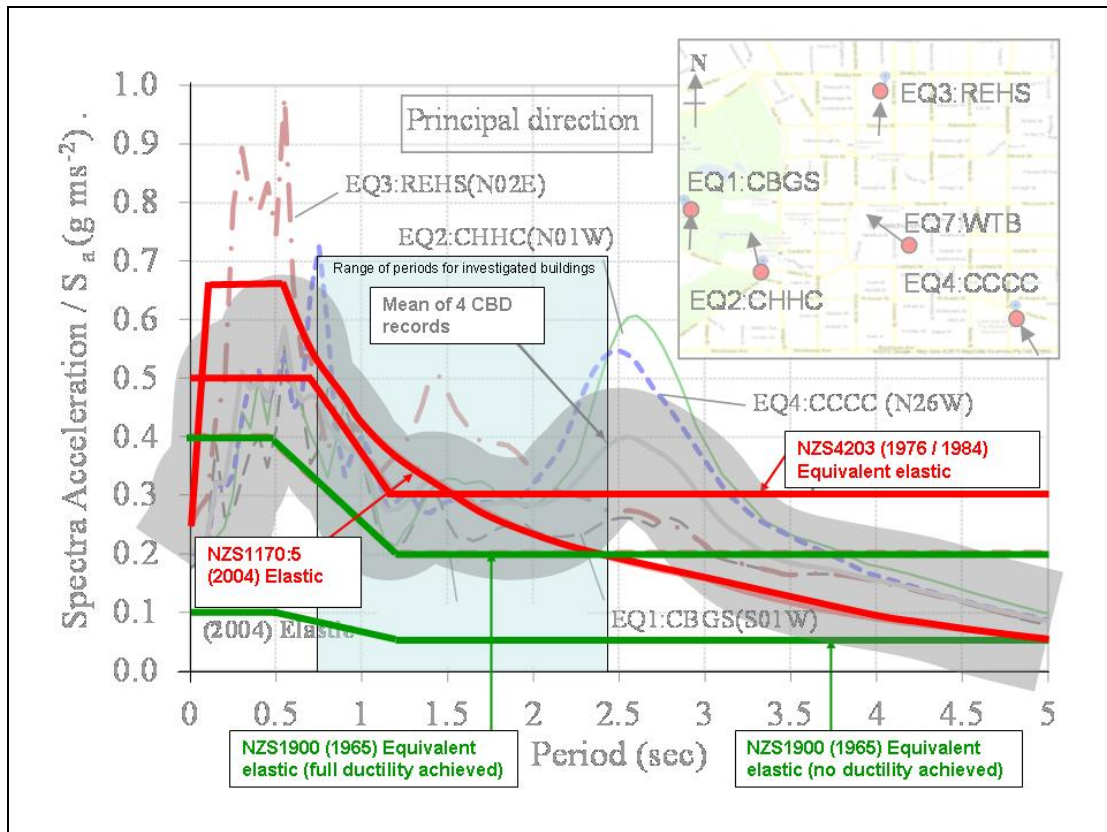

Figure 4.5 (a) Design versus demand – 4 September 2010

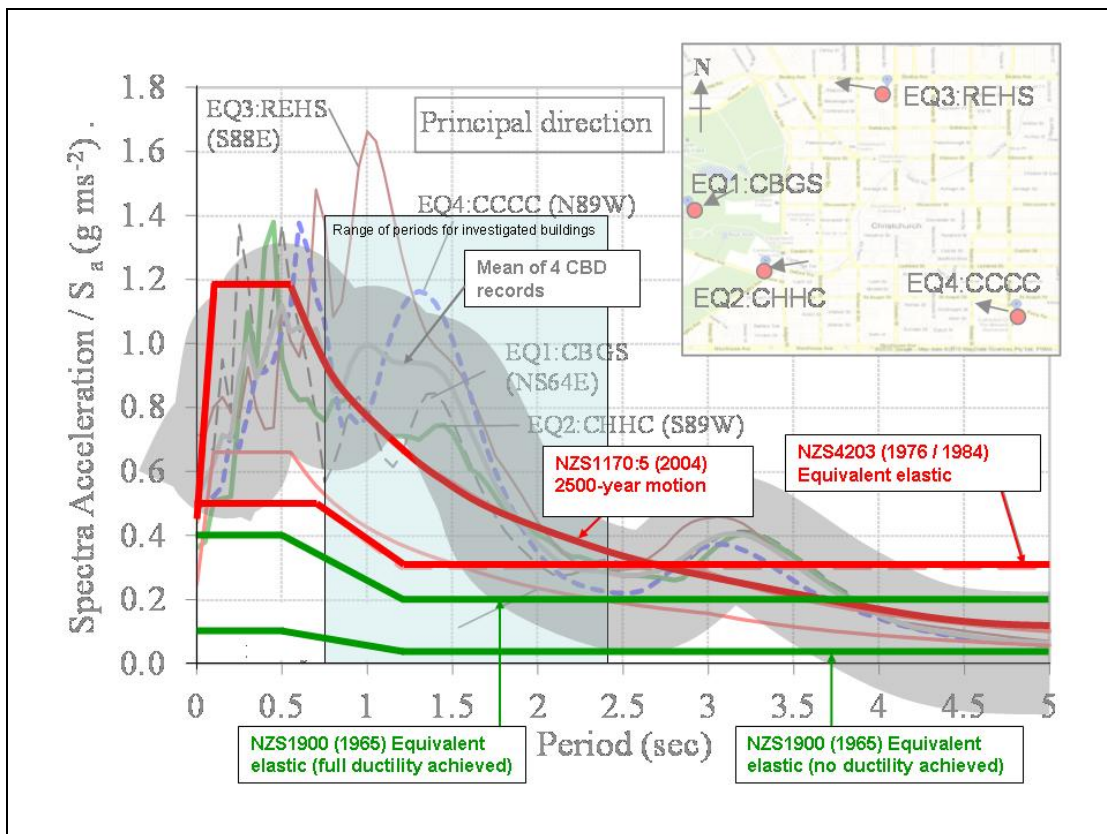

Figure 4.5 (b) Design versus demand – 22 February 2011

Comparison of the various design levels with the demand 'band' is clear in these modified figures. Note that the Figure 4.5(a) is to a different scale than Figure 4.5(b).

For the 4 September 2010 event, it can be seen that demand is broadly comparable to capacity, particularly when it is considered that a building designed to the standard is highly likely have an actual capacity greater than indicated by the standard line. Conservative assumptions built in to the structural design process mean that very few buildings would be expected to perform below the prescribed level for design.

The exceptional demands of the 22 February 2011 event are clear from Figure 4.5 (b) where the grey line is well above the prominent red line (representing design for a one in 500-year ground shaking level to the 2004 standard).

4.3.4. Limitations in the comparisons

The variability evident in the above figures indicates the challenges in determining the causes of failures in particular buildings in a real earthquake. But even these estimates are based on certain assumptions as to the properties of the building, notably that it will respond elastically and have defined response characteristics. In addition, for a particular building, the alignment of the building with the direction of the strongest earthquake shaking provides further challenges and uncertainties in the estimation of its response.

When relating the measured ground accelerations to a particular building site, differences in soil profile may change the characteristics of the ground shaking, and thus the building response.

There is considerable debate amongst engineers about interpreting recorded ground motion information and likely building response. In particular, it is difficult to explain, using the response spectra, why tall buildings suffered so little damage in the 4 September 2010 event.

4.3.5. Inelastic analysis

One tool that has helped in this investigation is inelastic time-history analysis (ITHA). In this technique, the building is not assumed to respond elastically, and this more realistically reflects actual behaviour. The measured ground motions are used as input and the response of the building is calculated taking account of any change in properties as the building deforms. For example, the stiffness (or period of vibration) of a building changes as the building deforms and various members yield (i.e. deform inelastically). The response spectra above do not take this into account, and it is clear from Figures 4.4 and 4.5 that even small modifications in period can make a large difference to response.

ITHA analyses completed for the PGC Building correlate well with the lack of significant damage on 4 September 2010, while similar analyses using the 22 February 2011 ground motion records clearly point to the demand exceeding capacity.

While ITHA brings its own uncertainties and variability, it is recognised as providing a more realistic estimate of building response than examination of the elastic response spectra provides.

4.3.6. General variability of building performance in earthquakes

It is important to recognise that the estimation of building response to a particular earthquake is subject to considerable variability and uncertainty. Responses quoted in the accompanying consultants' reports should be interpreted in this light. Quoted values of force or displacement, although they give a good indication of likely real values, could nevertheless vary quite significantly from those quoted.

In a broader sense, this variability helps to explain why buildings designed and built to meet the same requirements behave in markedly different ways. The conservatism built into structural design processes means that most buildings designed to a defined standard will, in reality, exceed that defined standard. Furthermore, most buildings are the first (and often only) one of their kind and this introduces significant variation into the performance of buildings, even between those of identical design. It is the combined variation in both demand and capacity that explains, in general terms, why some buildings fare much worse, or better, than others, or why one building collapses and another similar building does not.

5.0 Pyne Gould Corporation Building

5.1. Summary

The five-storey Pyne Gould Corporation (PGC) building located at 231-233 Cambridge Terrace, Christchurch, suffered a major structural collapse on 22 February 2011 following the Magnitude 6.3 aftershock.

The building collapsed when the reinforced concrete walls of the core of the structure between Level 1 and Level 2 failed. Subsequently, the perimeter columns and/or joints between the columns and the beams and the connections between the floor slabs and the shear-core failed, causing the floors to collapse.

The structure met the 1963 design requirements of that time for the prescribed earthquake loads, both in terms of level of strength and the level of detailing provided.

The principal reasons that the PGC building collapsed in response to the 22 February 2011 aftershock event were identified as being:

- that the intensity and characteristics of the ground shaking caused forces in the core wall of the building (between Level 1 and Level 2) that exceeded its capacity; and
- that the non-ductile design of the structure, typical of buildings designed in the early 1960s, lacked resilience once the building's strength had been exceeded and was unable to accommodate the shaking associated with the 22 February 2011 aftershock event.

5.2. Investigation

A technical investigation into the reasons for the collapse was commissioned by the Department of Building Housing and this was undertaken by engineering consultants Beca Carter Hollings and Ferner Ltd (Beca).



Figure 1: PGC Building prior to collapse (source: S. Tasligedik)

5.3. Building description

The five-storey office building, designed in 1963, was founded on shallow pads, and its lateral resilience was provided by walls surrounding the stairs and lifts. These walls formed a core, and were approximately symmetrically located about the north-south centre line of the building, but offset from the east-west axis. The axes of the rectangular building were orientated approximately north-south and east-west. These core walls had openings in some areas.

The perimeter of the building above Level 1 was supported on reinforced concrete columns. These were supported on beams which were cantilevered beyond the ground floor reinforced concrete columns. Refer to Figure 2.

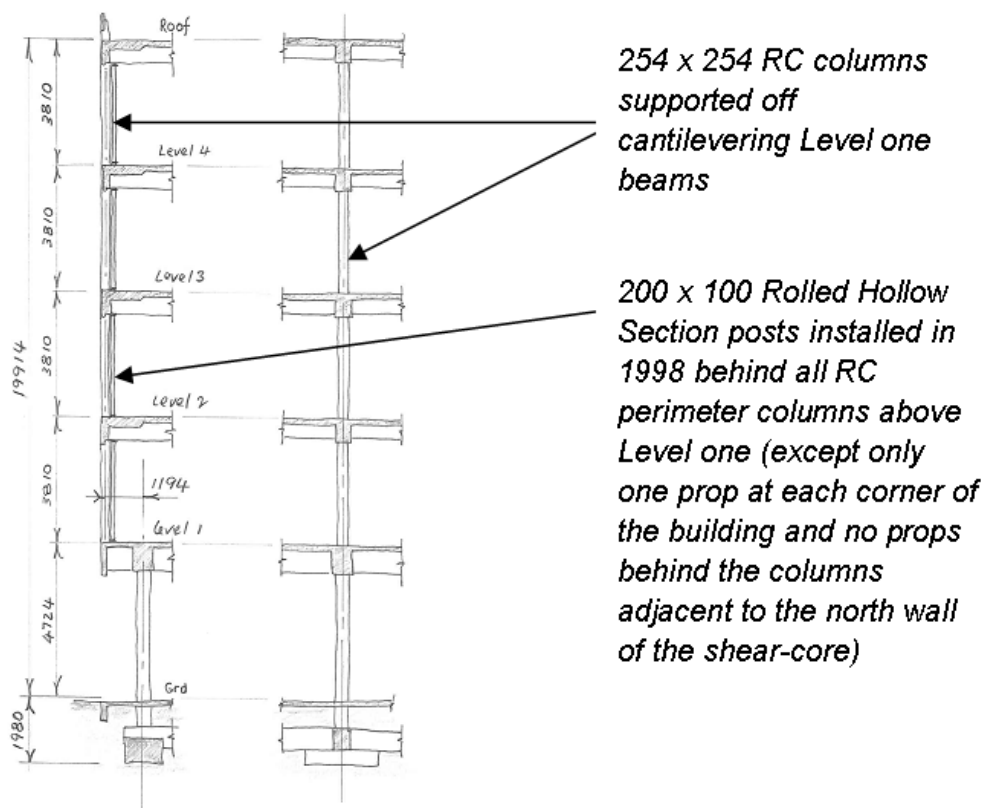

Figure 2: Section through building perimeter

A feature of the building, that affected the way in which it responded to the 22 February 2011 aftershock, was that the structure between Ground Level and Level 1 was significantly stronger and stiffer than immediately above Level 1. Refer to Figures 3 and 4.

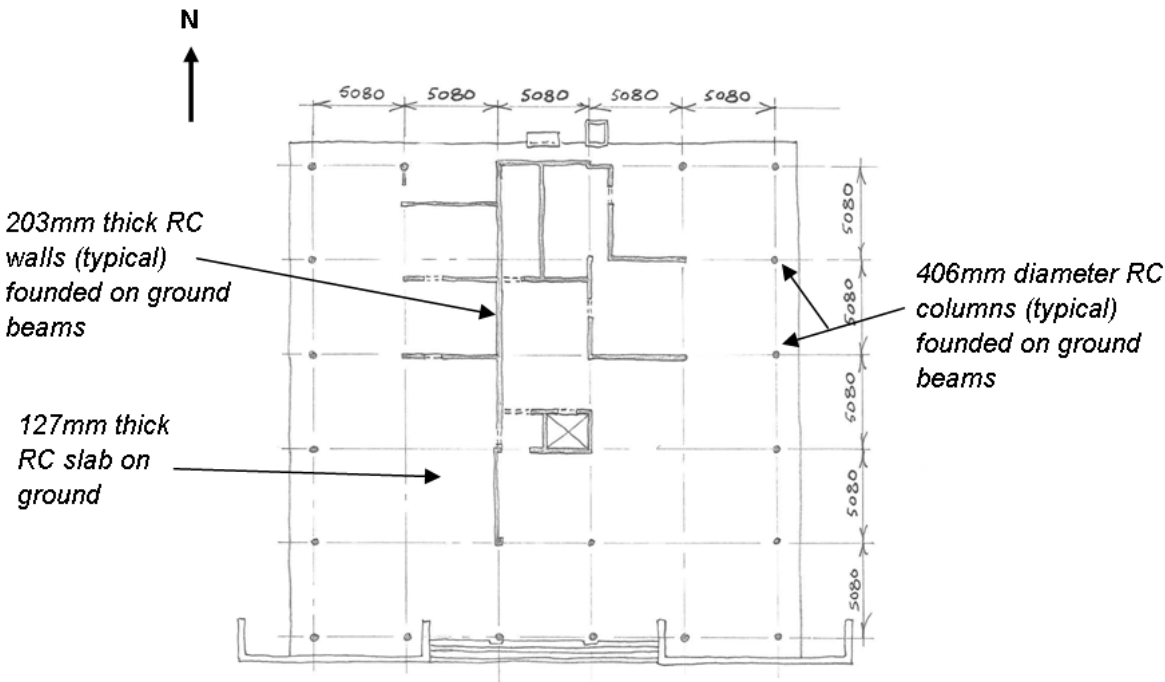

Figure 3: Ground Level plan of building

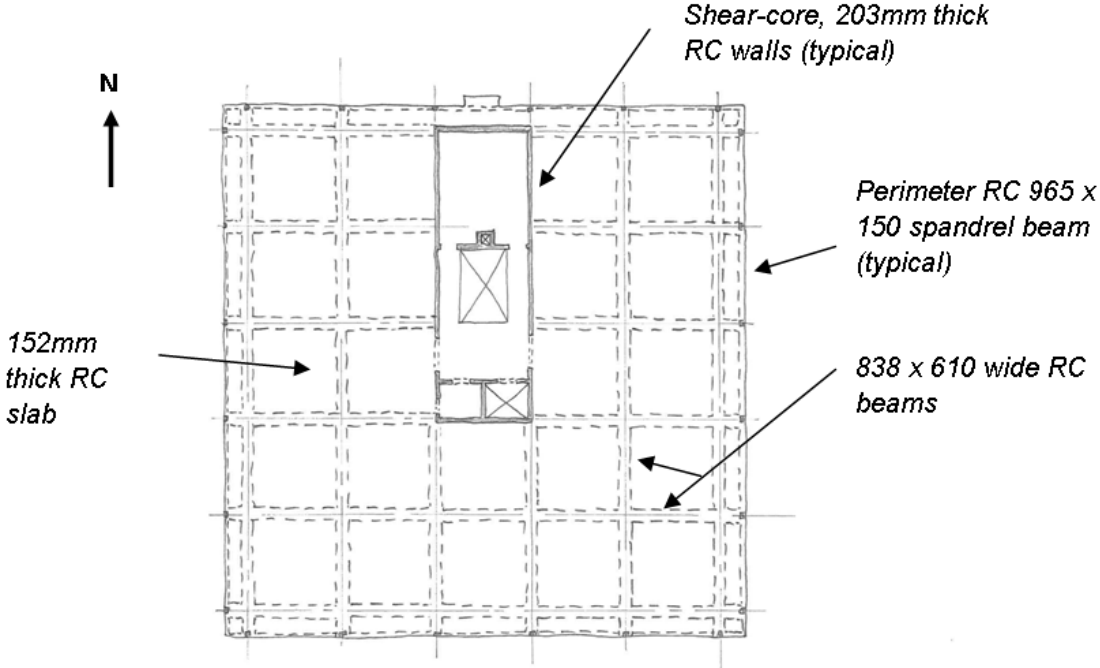

Figure 4: Level one plan of building

5.4. Structural modifications

During a 1998 major refurbishment, steel props were added to the perimeter reinforced concrete columns to enhance their vertical load-carrying capacity. Some investigations were undertaken into providing additional horizontal load resilience via steel bracing, but no additional horizontal resilience was added. Some openings in the concrete walls were in-filled and others created. At the same time as this refurbishment, decorative reinforced concrete umbrella structures on the roof were taken down because they were considered seismically unsafe.

In 2008, a 12 metre steel telecommunications mast was added to the central core walls above the roof level.

5.5. Design basis and code compliance

Calculations carried out as part of this investigation confirm that the core walls were reinforced to meet the seismic design loadings current in 1963.

A significant assessment of the building's earthquake resilience was undertaken for the owner in 1997. This identified shortfalls in resilience with respect to the loadings standard current at that time (NZS 4203: 1992).

The capacity of the building after the addition of steel props behind the perimeter columns in 1998 was judged, by the owner's engineer (at that time) to be in excess of 50% of the then current new building standard.

5.6. Geotechnical

Soils investigations, additional to those for neighbouring sites for other building developments over the life of the building, have been undertaken at the site and at the nearest earthquake-recording site (Christchurch Resthaven REHS, 670 metres to the north north-west).

Post-earthquake soils investigations gave no indication of deformation of the foundation and/or the site that would be instrumental in the collapse of the structure.

5.7. Seismological

The strong-motion recordings obtained from the nearest site (REHS) are considered relevant to the investigation of the building's performance and were used in the analyses. Although the ground conditions at the REHS recording site differ from those at the building site in some respects, they are considered to be the most appropriate to what was felt on the PGC site.

5.8. Effects of 4 September 2010 earthquake and 26 December 2010 aftershock

Minor structural and some non-structural damage was observed as a result of the 4 September 2010 earthquake. Some cracking was observed to the shear-core walls between Levels 1 and 2, to the stair flights, and to the extremities of some perimeter columns.

Witnesses have advised of damage observed after the 4 September 2010 earthquake. Some of this, but not all, has been correlated with known spalling from reinforcing bar corrosion and recorded damage.

After the 26 December 2010 Magnitude 4.9 aftershock, no significant additional damage was recorded.

The owner's structural engineers inspected the building after both the 4 September 2010 earthquake and the 26 December 2010 aftershock, and advised the owner it was acceptable to occupy it.

The extent and location of the damage observed/reported from the 4 September 2010 earthquake and the 26 December 2010 aftershock did not provide signs that the building had been significantly distressed in the shaking that had occurred, or of the collapse that was to occur.

5.9. Effects of 22 February 2011 event

The PGC Building collapse appears to have been initiated by the failure in compression of the eastern core wall between Levels 1 and 2. Almost no structural damage was observed between Ground Level and Level 1. The core walls above Level 2 were reportedly largely undamaged. The east half of the roof detached itself from the core and slid partly off the level below on to the adjacent building.

5.10. Probable reasons for collapse

Analytical models of the total structure and of the core walls alone have been created. Non-linear time-history analyses using actual records of the three events (4 September 2010, 26 December 2010 and 22 February 2011) recorded 670m from the building have been undertaken.

Analyses confirm that the core wall between Level 1 and Level 2 had insufficient capacity, by a considerable margin, to resist the intensity and characteristics of the ground shaking recorded at the nearest instrument on 22 February 2011.

5.11. Conclusions

The PGC building structure was in accordance with the design requirements of the time (1963), both in terms of the level of strength and the level of detailing provided.

Modifications made to structural elements (addition of perimeter steel props and insertion/deletion of doorways in the core walls) during the life of the building were not material with respect to the collapse on 22 February 2011.

When compared to the current code for new buildings (NZS 1170:5, 2004 NZS 3010: 2006), the PGC building would have achieved between 30 and 40%NBS (New Building Standard) prior to September 2010, when assessed against the New Zealand Society for Earthquake Engineering Guideline recommendations (NZSEE, 2006).

Testing of concrete and reinforcing steel elements retrieved from the collapsed building indicated that the strength and characteristics of those elements were consistent with those specified at the time of design.

The damage to the building as a result of the 4 September 2010 earthquake and the 26 December 2010 aftershock was relatively minor, and was not indicative of a building under immediate distress or having a significantly impaired resistance to earthquake shaking. The proposed method of repair at that time, of grouting the cracks, appears reasonable.

The investigation concluded that the damage observed and/or reported after the 4 September 2010 earthquake and the 26 December 2010 aftershock did not significantly weaken the structure with respect to the mode of collapse on 22 February 2011.

Analyses and site observations indicate the following sequence of collapse (refer Figure 5). The PGC building collapsed when the east and west reinforced concrete walls of the core between Level 1 and Level 2 failed during the aftershock. The west wall yielded in vertical tension, and then the east wall failed catastrophically in vertical compression. The ground floor structure stayed intact, virtually undamaged as it was significantly stronger and stiffer than the structure above. Torsional response (i.e., twisting of the building about a vertical axis) was not a significant factor. Once the west wall had failed, the horizontal deflections to the east increased markedly. The perimeter columns and/or joints between the columns and the beams, and the connections between the floor slabs and the shear-core failed consequentially at some levels, causing the floors to collapse.

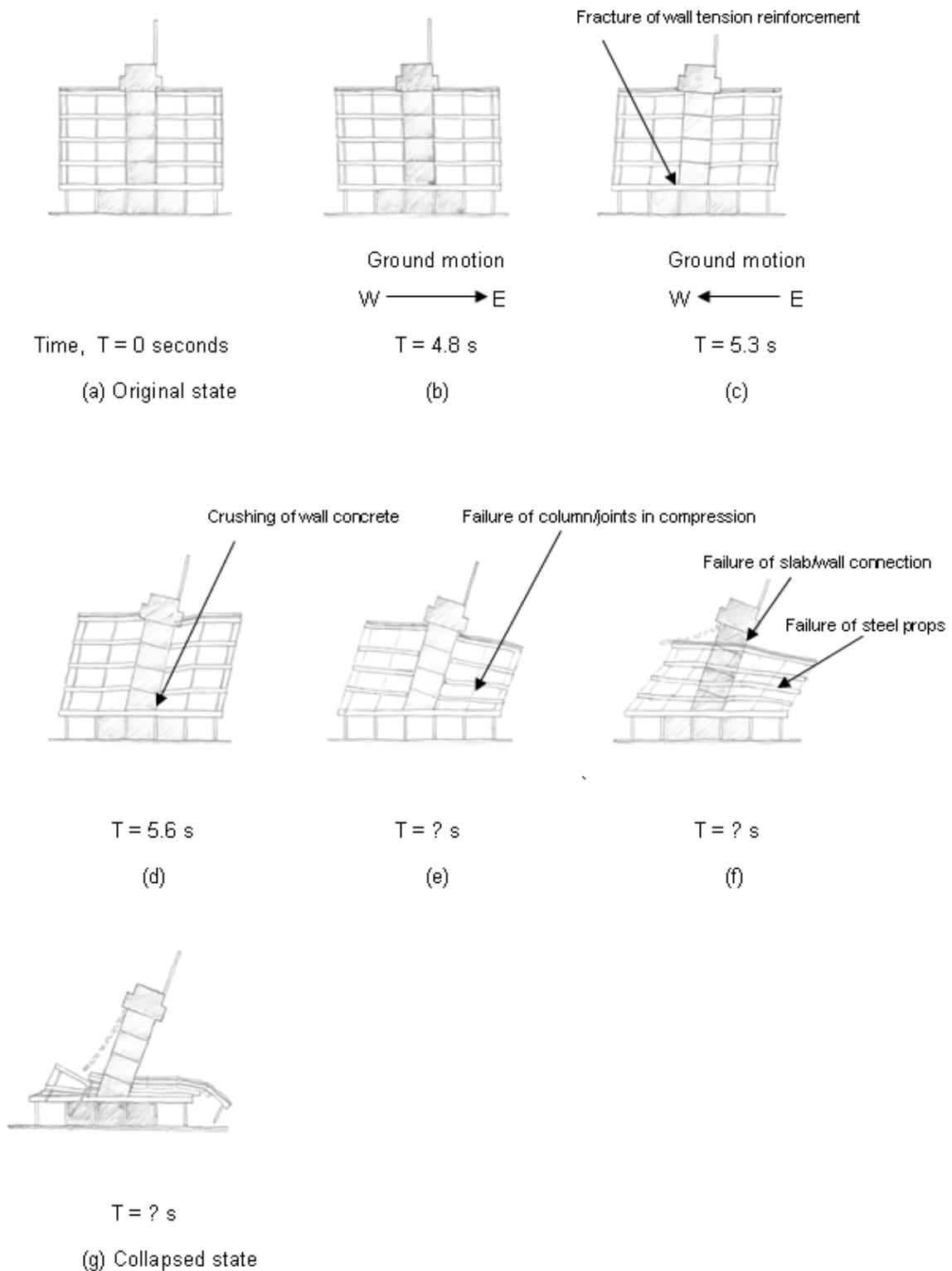

Figure 5: Inferred collapse sequence

The reason the PGC building collapsed was that the shaking experienced in the east-west direction was almost certainly several times more intense than the capacity of the structure to resist it. In addition, the connections between the floors and the shear-core, and between the perimeter beams and columns, were not designed to take the distortions associated with the core collapse. Neither foundation instability nor liquefaction was found to be a factor in the collapse.

Extensive studies undertaken in 1997 for a previous owner confirmed that the structure was below the current standard at that time with respect to earthquake resilience for new buildings.

5.12. Recommendations

Following the investigation of the PGC building and subsequent discussions with the Panel, a number of issues have arisen that the Department should give consideration to:

- ***Active approach to screening buildings for critical structural weaknesses***
The benefits of an active approach to the screening of existing buildings for critical structural weaknesses has been highlighted. Territorial Authorities should be encouraged to include such an approach in their earthquake-prone building policies.
- ***Shear walls***
The performance of the PGC Building during the 22 February 2011 aftershock has highlighted the potential vulnerability in large earthquakes of lightly, centrally, reinforced shear walls without concrete confinement, especially where the horizontal resistance to earthquake is provided solely by the shear wall. Further investigation of the potential seismic performance of existing lightly reinforced shear walls should be a priority.
- ***Building assessment guidelines***
The existing New Zealand Society for Earthquake Engineering building assessment guidelines should be reviewed so that buildings of the PGC Building type are identified as potentially poorly-performing in earthquakes.

6.0 Hotel Grand Chancellor Building

6.1. Summary

The Hotel Grand Chancellor complex located at 161 Cashel Street, Christchurch, suffered major structural damage following the Magnitude 6.3 aftershock on 22 February 2011. The extent of damage suffered by the building was significantly increased by the collapse of a key supporting shear wall which failed in a brittle manner.

Extremely high compression loads combined with low levels of confinement reinforcing led to the wall failure. The lapping of vertical reinforcing and the slenderness of the wall also appear to have contributed to the onset of failure. Under the action of high compression loads, a small transverse displacement was enough to initiate failure in unconfined concrete. The high axial loads arose from the building geometry and induced actions resulting from the severe horizontal accelerations. It is highly likely that vertical earthquake accelerations also contributed to the high compression loads.

The building deformations that resulted from the wall failure were sufficient to initiate a major stair collapse within the building and failures to columns and beams at various locations.

6.2. Investigation

A technical investigation into the reasons for the structural damage to the Hotel Grand Chancellor was commissioned by the Department of Building Housing and this was undertaken by structural consulting engineers Dunning Thornton Consultants Ltd.



Figure 1: Hotel Grand Chancellor pre-September 2010 earthquake
(source: C Lund & Son Ltd website)

6.3. Building description

The Hotel Grand Chancellor was built between 1985 and 1988 as a hotel with conference facilities.

The complex comprises a 22-storey reinforced concrete tower with an 8-storey interconnected podium on the south side. The upper 15 levels contain hotel accommodation while below that are 6 levels of car parking, split into 12 half-floors. The hotel lobby is located at the ground floor making a total of 28 levels. An adjacent car parking building, though structurally separate, shares the vehicle access ramps with the hotel.

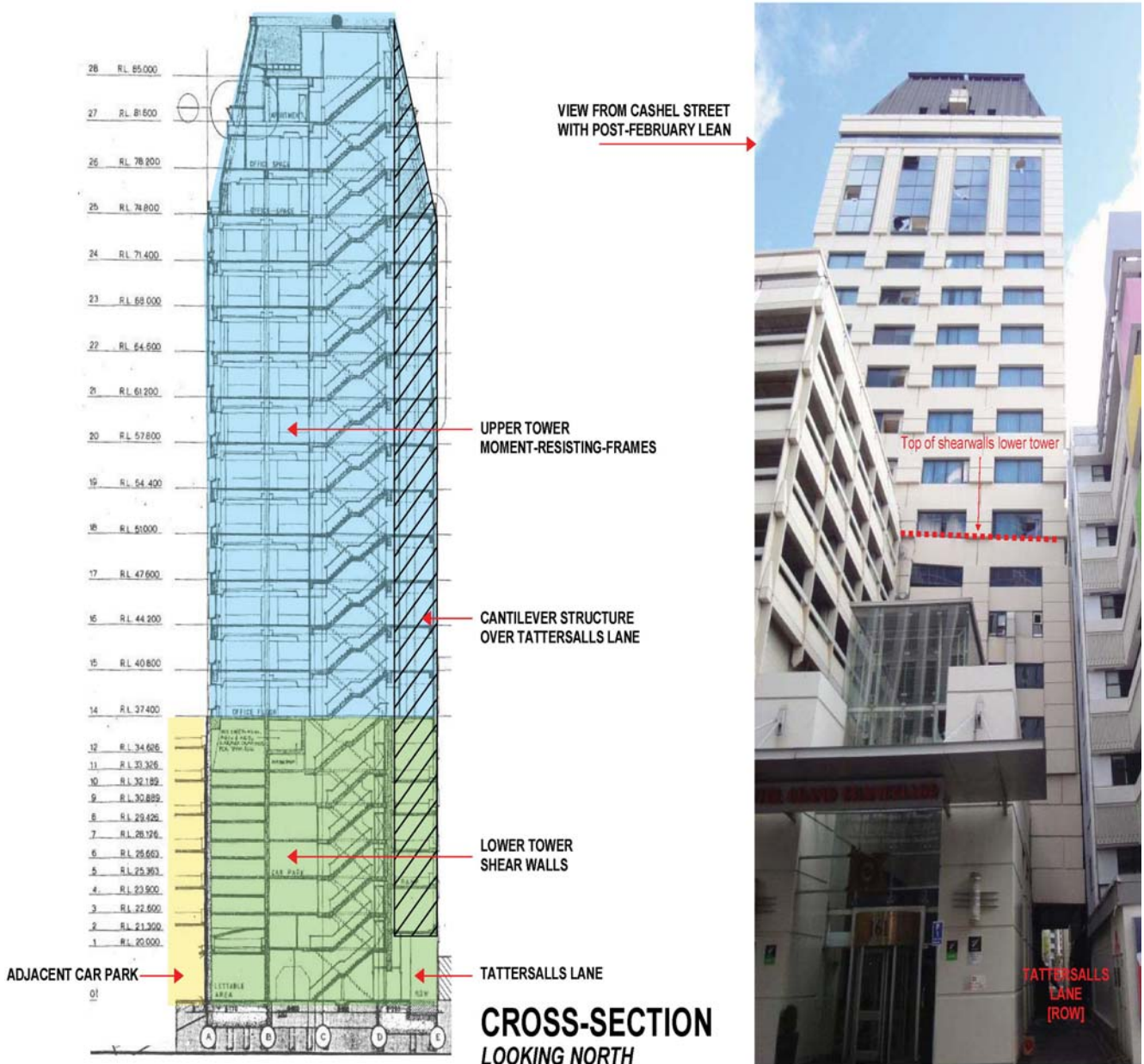

Figure 2: Plan showing Hotel Grand Chancellor cross-section (looking north) and a photograph showing the location of the shear wall (D5-6)

The Hotel Grand Chancellor structure has both vertical and horizontal structural irregularity. Vertical irregularity arises from the fact that the upper tower relies on frame action (moment-resisting reinforced concrete frames) for its seismic resistance while the lower tower relies on reinforced concrete shear walls. The two structural forms inherently have different stiffnesses and, if not linked, would respond differently to seismic shaking. The horizontal irregularity arises from the fact that the eastern bay of the building is cantilevered. Large cantilever transfer beams extend out to the east at Levels 12 to 14 above Tattersalls Lane to support the car park floors. Two of these cantilevered transfer beams sit on top of the key supporting shear wall (wall D5-6).

6.4. Structural modifications

At the ground floor of the complex a right-of-way exists along the east boundary of the site, occupied by Tattersalls Lane. Initial designs for the complex had involved foundations, columns and walls being constructed along (and within) this right-of-way. Construction of the building was reasonably well advanced before legal action effectively prevented construction of any structure within the right-of-way. This change required a structural redesign of the building.

The investigation did not find any evidence of significant structural alterations following the completion of the building.

6.5. Design basis and code compliance

The investigation found that, for the most part, the structural design appeared to be compliant with the codes and standards that were applicable when the structure was designed. However, for the failed wall D5-6, it does appear that there were some design assumptions that may have contributed to the failure. The design appears to have underestimated the magnitude of possible axial loads, and the wall lacked the confining reinforcing needed to provide the ductility required to withstand the extreme actions that resulted from the 22 February 2011 aftershock. The assessed response of the building to this shaking exceeded the actions stipulated by both the current and contemporary loadings codes for a building of this type, structural period (of vibration) and importance.

6.6. Geotechnical

Geotechnical investigations carried out at the time of the design of the building indicated a soil profile of sandy silts, silty clays and some fine sand overlying gravel at approximately 6m below ground level. Piles for the building were detailed at 500mm diameter and were required to be driven to found firmly in gravels.

There have been no significant surface signs of liquefaction in the vicinity of the Hotel Grand Chancellor site, and geotechnical advice is that the surrounding area had been not been subject to slumping or localised displacement.

While the underlying soil will have had an effect on the building's response to the 22 February 2011 aftershock, the investigation has concluded that there is no evidence of significant foundation failure.

6.7. Effects of 4 September 2010 earthquake and 26 December 2010 aftershock

The building survived the 4 September 2010 earthquake and the 26 December 2010 aftershock without apparent significant structural damage and was fully in use when the 22 February 2011 event occurred.

6.8. Effects of 22 February 2011 event

During the approximate 12 seconds of intense shaking that occurred in the 22 February 2011 aftershock, the Hotel Grand Chancellor building suffered a major structural failure with the brittle rupture of a shear wall (D5-6, refer Figure 3) in the south-east corner of the building. This shear wall provided vertical support for approximately one-eighth of the building's mass and was also expected to carry a portion of lateral earthquake loads. Damage to the base of the shear wall is shown in the photograph in Figure 4.

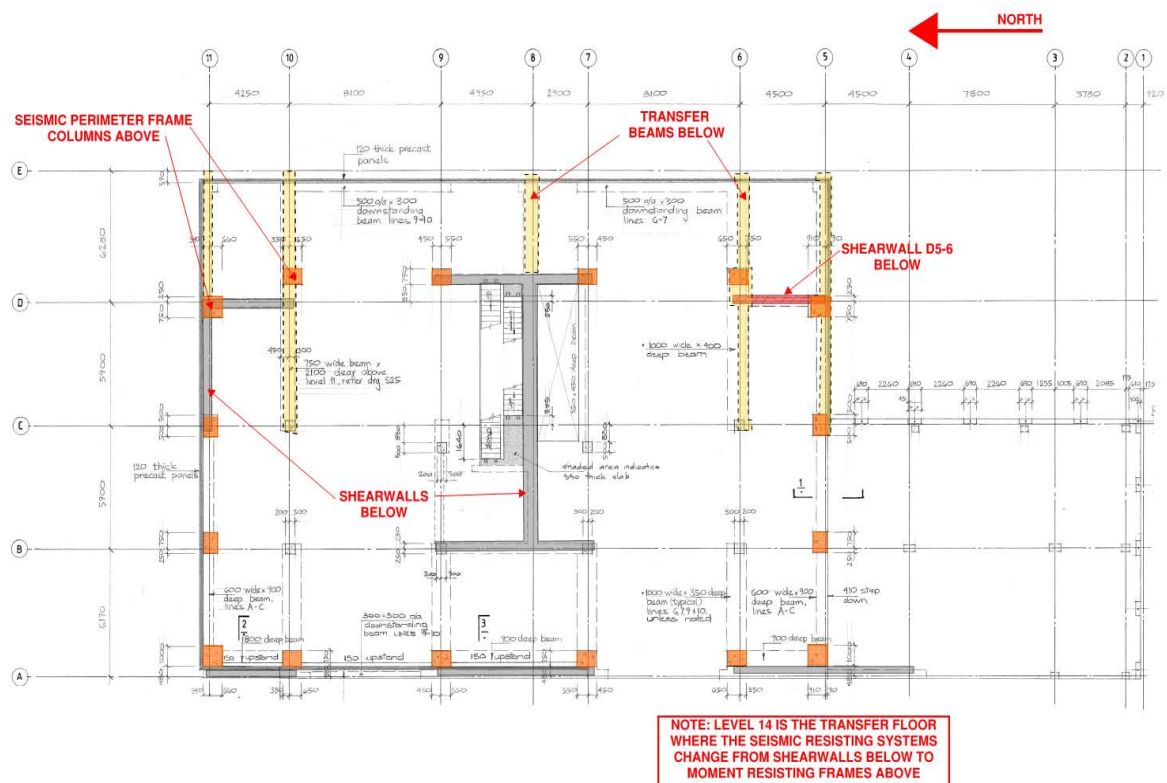

EXTRACT FROM ORIGINAL
STRUCTURAL DRAWINGS

LEVEL 14

Figure 3: Level 14 floor plan



Figure 4: Shear wall D5-6 base failure (in the hotel foyer)

As a result of the wall failure, the south-east corner of the building dropped by approximately 800mm and developed an accompanying horizontal lean of approximately 1300mm at the top of the building. This major movement induced other damage including column failure at the underside of the podium, beam yielding, stair collapse and pre-cast panel dislodgement. The collapse of the stairs, in particular, was dependent on the wall failure. Other more minor structural damage was consistent with what may have been expected in a well-performing reinforced concrete structure in a seismic event of this nature.

The 22 February 2011 aftershock induced actions within the wall that exceeded its capacity and caused failure and partial collapse.

There was sufficient redundancy and resilience within the overall structure to redistribute the loads from the failing element and halt the collapse.

6.9. Probable reasons for structural failure

Analysis suggests that the shaking of the 22 February 2011 event exceeded that stipulated by the code for a building of this type and importance in a 500-year event (New Zealand design standards stipulate a return period of 500 years for the seismic hazard relating to typical use buildings).

Observation and analysis suggests that high compression loads, combined with the low levels of concrete confinement led to the failure. Wall slenderness and the lapping of vertical secondary (web) reinforcing may have contributed to the onset of failure. When subject to high compressive stresses, unconfined concrete is prone to brittle crushing failure. In this

case, extremely high loads, together with some transverse displacement, were sufficient to initiate the concrete failure. The length of the confined zone at each end of the wall was very short and it is probable that the failure initiated behind the confined area, where the longitudinal reinforcing was lapped and unconfined.

The investigation concludes that the following factors contributed to the failure of the critical shear wall (wall D5-6) in the foyer:

- Larger than expected ground accelerations.
- Larger than expected acceleration and displacement demand to the building.
- Higher axial loads than allowed for in the design.
- The probable coincidence of high vertical accelerations with strong horizontal actions.
- The lack of robustness and resilience of the wall and its inability to sustain loads in excess of those allowed for in the design.

Factors and features that contributed to a critical vulnerability within the building included the following:

- Horizontal irregularity of the building arising from the cantilevering of the building over Tattersalls Lane resulting in a disproportionate contributing area being supported by the wall D5-6.
- Vertical irregularity from a framed structure on top of a shear wall podium with transfer beams at the interface.
- Extremely high axial (vertical) wall actions arising from a combination of:
 - gravity (dead plus imposed) loads
 - axial loads resulting from over-strength beam shears
 - actions resulting from in-plane forces in the storey-high cantilever transfer beams
 - vertical earthquake actions
 - code defined actions exceeded by the 22 February 2011 aftershock.
- Wall slenderness ratio that did not meet code requirements for the levels of axial load.
- Insufficient confinement at the base of wall D5-6, in respect to code.
- Insufficient available ductility in the critical wall D5-6 relative to the demands of the 22 February 2011 aftershock.
- Lapping in a wall end/hinge zone.

Stair flights collapse:

Analyses carried out under this investigation indicate that:

- The stairs are unlikely to have collapsed under the earthquake actions on 22 February 2011 had the wall D5-6 not failed.
- The displacements of the building due to the failure of the wall D5-6 were sufficient to cause collapse of the stairs above Level 14.

Displacements between adjacent floors under design loadings were estimated to be an average of 60mm per floor over the height of the frame. Taking account of tolerances and variability of inter-floor displacement, this dimension could vary by up to 20mm for any one floor. The stair detail provided for 70 to 80mm of horizontal spreading movement of the supports, but there was minimal provision for closing movement. Under the 22 February 2011 ground shaking, the average displacements were estimated to be 65mm per floor.

There was no damage to the stair flights, although there was evidence of damage due to compression at the supports, but it was considered that the stairs did not significantly affect the structural response.

Surveys of the building following the collapse showed that the permanent displacement of the tower in line with the stair was 1000mm. It is likely that a further elastic displacement estimated at 250mm occurred at the time of the failure. Thus the total displacement of the tower at the time of the aftershock was likely to have been about 1250mm, which is 90mm per floor. For any one floor, this displacement could be between 70 and 110mm. When compared with the 70 to 80mm of seating available, this points to a very high likelihood of stair collapse.

6.10. Conclusions

Examination and analysis suggests that the building structure was generally well designed. Indeed the overall robustness of the structure forestalled a more catastrophic collapse. However the shear wall D5-6 contained some critical vulnerabilities that resulted in a major, but local, failure. Other shear wall failures of similar appearance have been observed in other buildings following the 22 February 2011 aftershock, and this suggests that a review of both code provisions and design practice is warranted.

6.11. Recommendations

This section contains some recommendations arising from observations made during the investigation of the Hotel Grand Chancellor building and the meetings of the Panel. Some are quite specific to structural features that are contained within the Hotel Grand Chancellor and some are more generic, relating to design codes and practice generally. The matters set out below are ones that the Department should give consideration to:

- ***Design rigour for irregularity***
While current codes do penalise structures for irregularity, greater emphasis should be placed on detailed modelling, analysis and detailing. An increase in design rigour for irregularity is required.
- ***Design rigour for flexural shear walls***
The behaviour of walls subject to flexural yielding, particularly those with variable and /or high axial loads, has perhaps not been well understood by design practitioners. An increase in design rigour for wall design generally, and in particular for confinement of walls that are subject to high axial loads, is required.

- **Stair review**
A review of existing stairs, particularly precast scissor stairs, should be promoted and retrofit undertaken where required.
- **Stair seating requirement**
The introduction of larger empirical stair seating requirements (potentially 4%) for both shortening and lengthening should be considered. This should be included in earthquake-prone building policies.
- **Floor-depth walls**
The consequences of connecting floor diaphragms with walls that are not intended to be shear walls requires particular consideration. A Design Advisory relating to walls/beams that are connected to more than one floor, but which are not intended to act as shear walls, should be considered.
- **Design rigour for displacement induced actions**
Designers generally have tended to separate seismically resisting elements from 'gravity-only' frames and other elements of so-called secondary structure. However, not enough attention has always been paid to ensure that the secondary elements can adequately withstand the induced displacements that may occur during seismic actions. Non-modelled elements should perhaps be detailed to withstand 4% displacement. Modelled elements should be detailed to withstand a minimum of 2.5% displacement. An increase in design awareness relating to displacement induced actions should be promoted.
- **Frames supported on cantilevers**
Although this is not a common arrangement, caution needs to be taken when supporting a moment resisting frame on cantilever beams as effective ratcheting can lead to unexpected deflections. A Design Advisory relating to ratcheting action of cantilevered beams and frames should be considered.

7.0 Forsyth Barr Building

7.1. Summary

The 18-storey Forsyth Barr Building located on the south-east corner of Armagh and Colombo Streets, Christchurch, suffered an internal collapse of its stairs following the Magnitude 6.3 aftershock on 22 February 2011.

The stairs collapsed on one side of the stairwell up to Level 14, and on the other up to Level 15. The stairs were designed in a “scissor” arrangement, and were the only means of emergency egress from the building.

The stairs as designed met the 1988 design requirements for the prescribed earthquake loads and required seismic gap.

The principal reasons that the stairs collapsed were:

- the intensity and characteristics of the shaking of the 22 February 2011 aftershock exceeded the design capacity of the stairs in terms of distance provided for the stairs to move on their supports in an earthquake (the seismic gap); and
- it is possible that the seismic gaps at the lower supports had been filled with material that restricted movement (including debris, mortar or polystyrene) which reduced their effectiveness.

7.2. Investigation

A technical investigation into the reasons for the stair collapse was commissioned by the Department of Building Housing, and this was undertaken by engineering consultants Beca Carter Hollings and Ferner Ltd (Beca).



Figure 1: The Forsyth Barr Building from Armagh Street (looking south-east)

7.3. Building description

The Forsyth Barr Building, designed in 1988, is founded on a shallow raft, and its lateral resilience is provided by the frame action of the reinforced concrete beams and columns. For three levels above the Ground Level, the floors extend beyond the footprint of the tower to form a podium on the south and east sides. A typical floor plan is shown in Figure 2.

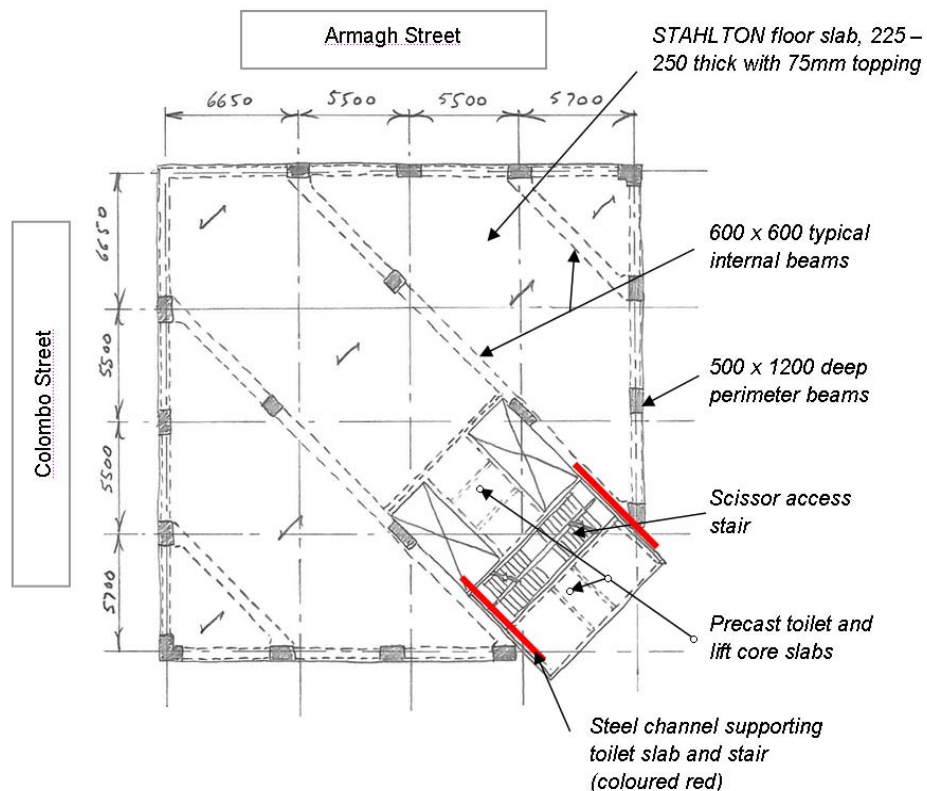

Figure 2: Typical floor plan

Emergency egress from the building was provided by a “scissor” stair system. This stair arrangement is exemplified in Figure 3.

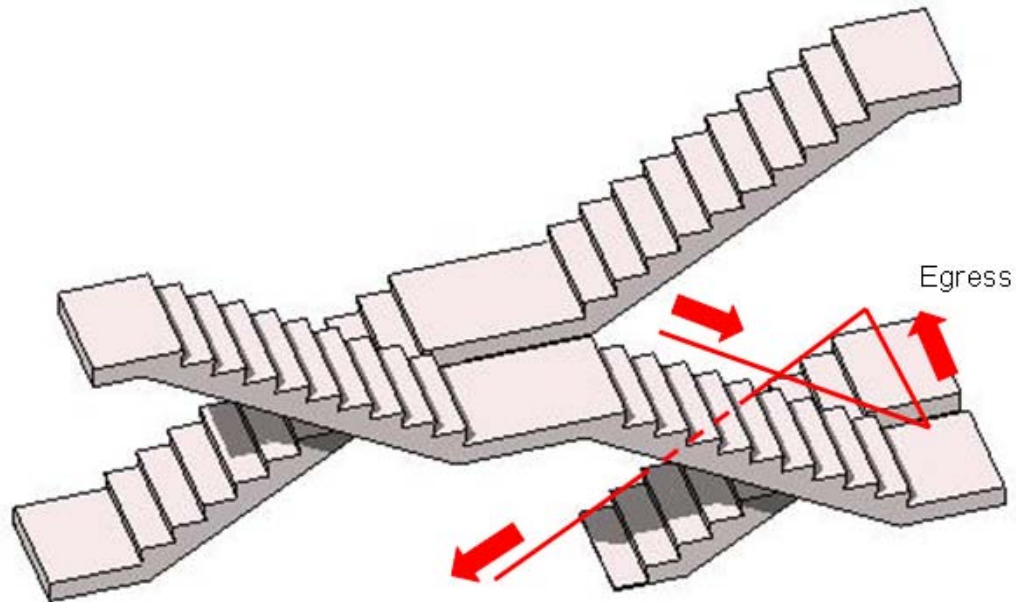

Figure 3: 3D view of typical Scissor Stair System between two adjacent levels

The stairs are orientated diagonally within the tower in a north-east/south-west direction. The majority of the stair flights were pre-cast units cast into the landing at their upper ends, and seated on a steel channel at their lower ends which, in an earthquake, allowed the lower end to slide within limits. This provided a horizontal gap specified at 30mm wide for the closing cycle and 73mm for opening (refer Figure 4).

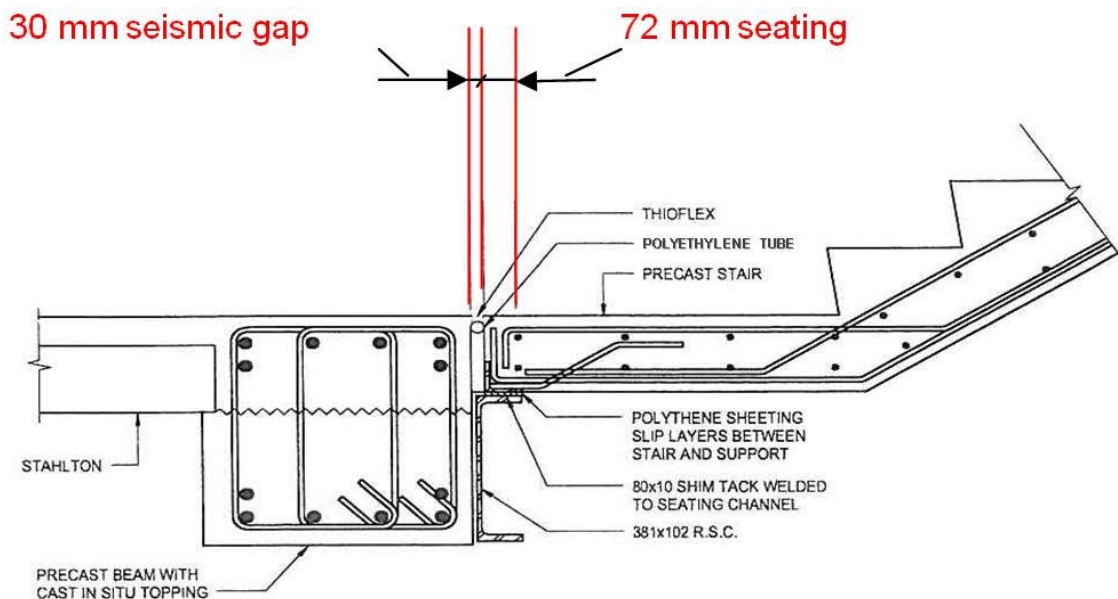

Figure 4: Typical stair bottom support detail

7.4. Structural modifications

There is no evidence of significant structural changes being made to the building since its construction.

In September 2011, the investigation team were able to inspect the stairs at Levels 14, 15 and 16 by external crane. From this site visit indications that these seismic gaps may not have been constructed in accordance with the drawings were noted.

Evidence was found of modification to the lower end of at least four stair units (two units inspected after removal and two still in place) that may indicate the prescribed seismic gap at that end was not achieved in all cases during construction.

7.5. Design basis and code compliance

There were no issues identified to indicate design non-compliance with respect to the code of the day. The seismic gap complied with the code of the day but this 1988 design would be only 80% of current requirements. In other respects a stair system within a building designed in 1988 could be expected to perform to essentially the same level as stairs in a similar building in 2010.

The pre-cast stair units in the tower were designed to be cast into the floor at their upper levels, and to be free to slide horizontally, within limits, at their lower ends. The stairs as designed met the 1988 design requirements for the prescribed earthquake loads.

7.6. Geotechnical

Soils data has been obtained from records and from new investigations. These records were used as input data for structural analyses of the building.

Surveys of the site have shown that the foundations of the Forsyth Barr Building did not move significantly, relative to the surrounding ground in the aftershock of 22 February 2011.

7.7. Effects of 4 September 2010 earthquake and 26 December 2010 aftershock

Minor structural damage was observed after the 4 September 2010 earthquake, including cracking and vertical displacement in some of the stair units and to the floor covering at the landings, cracking in the main structural frame members, and failure of a weld in the region of a car park ramp.

The Level 1 Rapid Assessment undertaken within a few days of the 4 September 2010 earthquake, under the authority of Civil Defence, resulted in the building being tagged Red – Unsafe. This was changed to Yellow – Restricted Access in the course of completing the Level 2 Rapid Assessment undertaken by the property manager's structural engineer. The building was re-tagged Green – Inspected following a small repair (to the vehicle ramp) and further inspection of the stairs.

Subsequently, the owner's structural engineer undertook an inspection of the building, and prepared instructions for the repair of cracked structural elements. Instructions had been given for any cracks over a certain size, visible in the stairs, to be repaired by injection of an epoxy grout.

Inspections of the most damaged flights of stairs carried out immediately after the 4 September 2010 earthquake did not reveal there had been any significant movement at the lower support.

Building occupants interviewed have stated that repairs to earthquake damage to floor coverings on the stairs in the period between the 4 September 2010 earthquake and the 22 February 2011 aftershock were underway.

Structural engineers inspected the building after the 4 September 2010 earthquake and the 26 December 2010 aftershock, and advised the owner that it was acceptable to occupy.

There were no reports of further structural damage to the building after the 26 December 2010 aftershock.

7.8. Effects of 22 February 2011 event

In the 22 February 2011 aftershock, the Forsyth Barr Building suffered a collapse of the main stairs from the Ground Level to Level 15 (one flight) and from the Ground Level to Level 14 (the other flight). The upper part of a column supporting the south-east corner of the podium roof was also significantly damaged.

The investigation team were able to obtain copies of reports prepared by the building owner's engineers (dated 31 March 2011 and 13 April 2011) that indicate the damage to the building structure was relatively minor. Laser scanning of the north and west facades of the building undertaken for Civil Defence, did not indicate any significant permanent distortion of the structure. Although the investigation team inspected the stair units still in place at Levels 14, 15 and 16 in September 2011, it was not possible on that occasion to determine the extent of damage to the building structure.

The removal of the collapsed stair units necessitated cutting them in half at their middle landings, and no records were available of which units were already broken/damaged at their mid-height landings, or from which levels the various pieces originated. Stairs that had been removed from the building after the 22 February 2011 aftershock were tested in terms of core strength of concrete and tensile strength of reinforcing steel. Both concrete and steel properties were found to be consistent with code limits and building specifications. Evidence of cutting/grinding of the lower ends of at least two stair units (presumably to increase the in-place seismic gap) has been seen. It is believed that this occurred during construction.

Analytical models of the structure were subjected to the effects of two seismic events (4 September 2010 and 22 February 2011) by applying records from the nearest GeoNet recording station (REHS, Christchurch Resthaven). In addition, analyses of a typical stair unit were undertaken a) to determine the effect of vertical accelerations, and b) to understand its failure mode if it were to be placed under compression and/or sideways bending due to differential horizontal movement between adjacent floors.

The analyses for the 22 February 2011 event estimated inter-storey drifts between Levels 13 and 14 of 65mm in one direction and 45mm in the reverse direction (refer Figure 5) and these values were used to assess the collapse scenarios.

Analyses for the 4 September 2010 event showed inter-storey drifts between Levels 13 and 14 in the region of 30mm, which corresponded to initiation of damage and compression to the stair flights. This matched the level of damage observed.

7.9. Mode of collapse

It seems likely that the uppermost stair units collapsed first, possibly progressively impacting the units below. Interviews with occupants suggested that all the stair collapses occurred during the main shock over a short period of time.

The support at the bottom landing of each stair unit was likely to have been lost first, allowing the unit to pivot downwards about its upper end which was cast into the upper landing. In most cases, the cast-in reinforcing steel at the upper landing has yielded and then snapped, presumably allowing the stair unit to fall down the building in a near-vertical attitude. The investigation team was advised that some of the stair units did not detach from their upper connections, and were left hanging in the stairwell until removed by USAR.

The exact sequence of the stairs collapsing has not been determined. Figure 5 details the possible stages involved in the collapse of a stair flight.

On any one stair unit, the lower seating support could have been lost for one of (or a combination of) the following reasons:

- The stair unit has been compressed, resulting in it bending downwards and yielding its reinforcement, because the seismic gap was smaller than needed in the 22 February 2011 aftershock. This resulted in permanent shortening of the stair. On the reversal of the horizontal motion of the floors this shortening was sufficient for the lower landing to fall off its support.
- Analyses completed indicate that inter-storey displacements (drifts) were likely to be highest in the region of Levels 10 to 14.
- The lower stair landing failed in shear when the stair unit was subjected to compression after the seismic gap was closed.
- The effective horizontal length of the stair unit was shortened when struck by the stair unit above, after the unit above lost its seating and rotated downwards about its upper landing. The consequent V-shaped lower unit would then have dragged its lower landing off its seat.
- A free-falling stair unit simply impacted the still-intact unit, causing it to fail catastrophically and fall.
- Construction tolerances and the possibility that the seismic gap at the lower stair support had been filled (with debris, mortar or polystyrene), would have reduced the level of building horizontal displacement required to fail the stair. Even though the stair separation gaps as designed met the code of the day, analyses indicate that the collapse would have occurred even if the joints had been fully free to move.

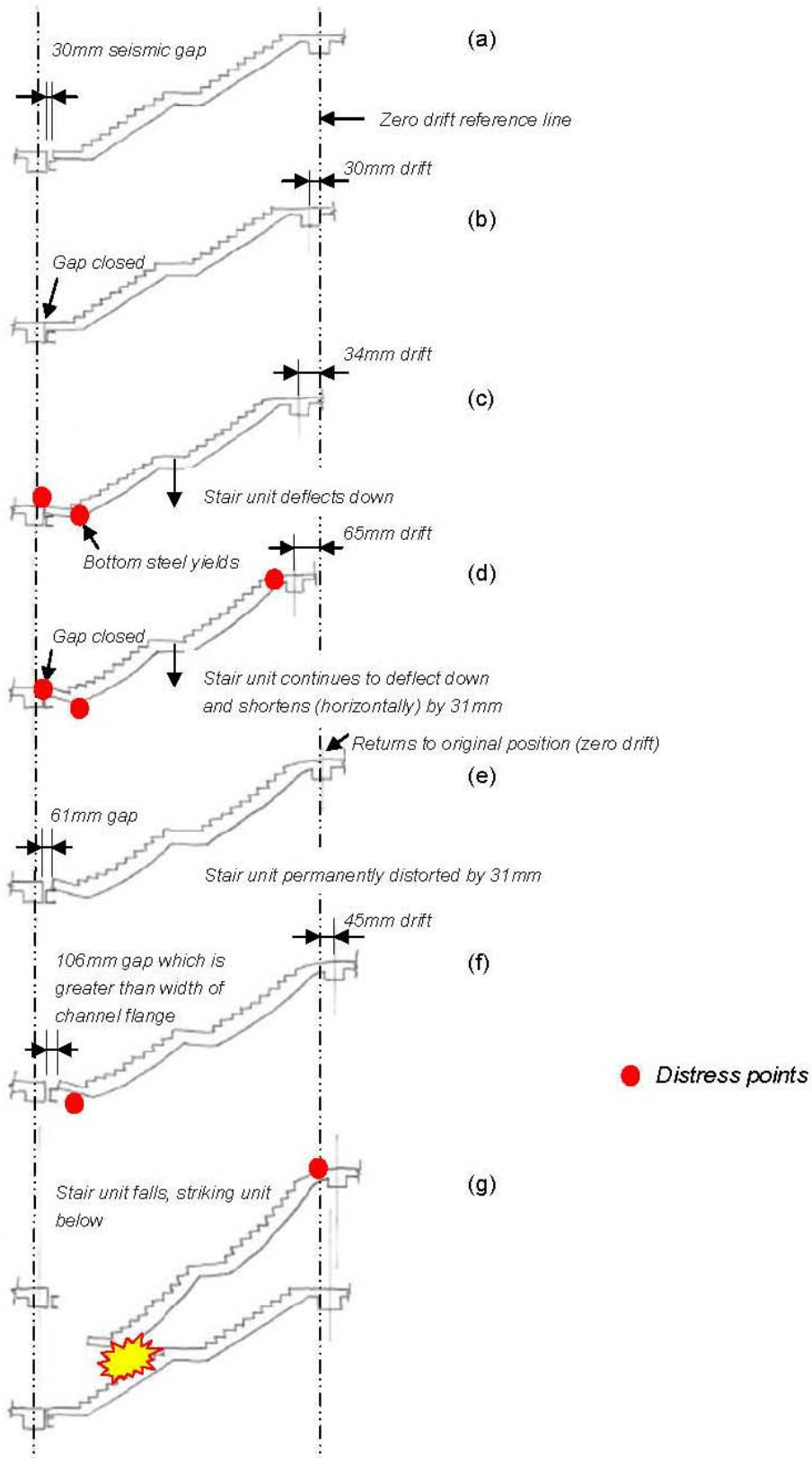

Figure 5: Inferred collapse sequence

7.10. Probable reasons for collapse

The actual seismic gaps at the bottom landings were too small for the aftershock shaking experienced on 22 February 2011. The characteristics of the lower seat did not allow any latitude if the building horizontal inter-storey displacements in an extreme event were such that they exceeded the gap provided.

The stair units were not designed to resist compression that would arise from the closing up of the seismic gap.

Construction dimension tolerances (and if, as suspected, the seismic gap at the lower stair support had been filled with debris, mortar or polystyrene) would have reduced the level of relative horizontal displacement between floors required to fail a stair.

The damage observed and/or reported after the 4 September 2010 earthquake and the 26 December 2010 aftershock was not considered to have significantly weakened the stairs to make them more vulnerable in the 22 February 2011 aftershock. Time-history analysis indicated a level of displacement that was consistent with this observation.

7.11. Conclusions

Although the seismic gap at the lower stair support met the code of the day, it was too small for the aftershock event of 22 February 2011. There is also evidence that the available seismic gap was not large enough to prevent some stair flights being compressed and slightly damaged during the 4 September 2010 earthquake. The specified gap was sufficient for the shaking experienced in the 26 December 2010 aftershock.

The seismic gap specified on the drawings met the design standards prevailing at the time the building was designed. The specified gap would not have been sufficient to avoid compression if the current (2010) code-derived displacements had been applied.

When comparing the stairs as constructed in the Forsyth Barr Building with the current code, it was found that the original design would not meet current requirements (introduced in 1992) as the 1988 design requirements for clearance between stairs and structure would only be 80% of current requirements.

It could not be definitively established whether the specified seismic gap was provided everywhere, or whether there was debris, mortar or polystyrene in the gaps everywhere, which would have reduced the effectiveness of the gap. Despite the presence of extraneous material in the spaces intended for seismic movement, indications are that the stairs would have collapsed even if this material had not been present and the stairs had been fully free to move.

There was no evidence found in the investigation that indicated that repairs that were underway to the stair coverings prior to 22 February 2011 had an impact on the stair collapse.

The fact that the stairs had been pre-cast as one unit, rather than as two separate units to be connected at mid-height landing, was not considered to have been likely to have had any effect on the collapse.

No evidence (physical or analytical) could be found to suggest that vertical earthquake motion (or response of the stair over its length) experienced in the 22 February 2011 aftershock caused or significantly contributed to the stair failure.

7.12. Recommendations

Following the investigation of the Forsyth Barr stairs and subsequent discussions with the Panel, a number of issues have arisen that the Department should give consideration to:

- ***Alternatives to seismic gap detail***
Known alternatives to the seismic gap detail used in this building should be used on all new buildings, and for replacing the stairs in this building. These alternatives minimise significantly any likelihood of the stair collapsing because of insufficient displacement allowance.
- ***Advisory note for gap-and-ledge stair detail***
An advisory note that warns of the potential issues and lack of resilience with the gap-and-ledge stair detail for new and existing buildings should be issued.
- ***Building Code provision for clearances and seatings for stairs***
A provision should be included in the Building Code requiring clearances and seatings for stairs to be capable of sustaining at least twice the Ultimate Limit State (ULS) inter-storey displacements, after allowances for construction tolerances.
- ***No compromise on seismic gaps***
The concept that a specified seismic gap must not be compromised under any circumstances should be promoted.

8.0 Principal Findings and Recommendations

8.1. Introduction

This chapter presents principal findings and recommendations on issues identified in the investigation reports on the PGC Building, the Forsyth Barr Building and the Hotel Grand Chancellor Building. Although these buildings represent a small sample of the overall building stock affected by the 22 February 2011 aftershock, the issues and recommendations may apply to many other buildings in Christchurch and to other places in New Zealand.

In presenting these findings and recommendations, the Panel has been aware of the considerable uncertainty surrounding the interpretation of the characteristics of ground shaking at the subject sites and the estimation of building response. The analyses and conclusions described in the investigation reports, including postulated collapse mechanisms, need to be interpreted with care, recognising that there may be other possibilities. Nevertheless, the Panel is confident that the general nature of the findings of the investigations reflects the most likely possibilities.

8.2. Findings

1. *Ground shaking / building response:* The estimated responses of buildings to recorded ground shaking in the Christchurch CBD on 22 February 2011 are shown, in most cases, to be significantly greater than is allowed for in the design of new buildings.
2. *Vertical accelerations:* The vertical accelerations measured in the 22 February 2011 aftershock were exceptionally high and may have contributed significantly to vertical forces in columns and walls. The extent of this contribution is difficult to quantify.
3. *Duration of shaking:* The duration of the 22 February 2011 aftershock was relatively short. A longer duration earthquake is likely to have had a greater effect on buildings, especially on structures that are not well tied together.
4. *Liquefaction effects:* The effects of liquefaction and lateral spreading were not significant for any of the three buildings covered in this report.
5. *Foundation distress:* Foundation distress was not a factor in the collapses. There was no evidence of foundation settlement or failure in any of the buildings.
6. *Effect of prior earthquakes:* The 4 September 2010 earthquake and the 26 December 2010 aftershock were not considered to have significantly reduced the subsequent earthquake resistance of any of the three buildings.
7. *Reasons for collapses:* The Panel supports the conclusions of the investigations as to the most likely reasons for, and the modes of, collapse/failure:

- a. *PGC Building*: The lack of ductility and strength inherent in the 1963 standards, and the strong shaking, all combined to fail the eastern wall of the building's shear core. The resulting horizontal displacement of the floors led to the failure of the columns and beam-column joints, causing the floors to collapse on top of one another.
- b. *Hotel Grand Chancellor*: The failure of a critical shear wall was caused by high axial loads combined with insufficient confinement of the concrete at the base of the wall. The critical wall's vulnerability was increased as a result of a design change during construction when permission to support the east face of the building on foundations located in Tattersalls Lane was declined. Vertical accelerations are likely to have further increased loads beyond those expected. The redundancy and resilience of the remaining structure prevented total collapse.
- c. *Forsyth Barr Building stairs*: The strong shaking caused the building to sway beyond design expectations current at the time of the building design. Extraneous material in the spaces intended for seismic movement appears to have made the collapse of stairs more likely. However, indications are that the collapses would have occurred even if the seismic gaps had been fully free to move. The collapses may not have occurred if current (2010) design allowances for inter-storey movement had applied.

8.3. Priority recommendations

- 1 *Stairs*: A Department Practice Advisory is urgently needed to warn owners of buildings, especially those built prior to 1992, to check that all egress stairs are designed to accommodate earthquake movement. Reviews are needed to check the following:
 - a. That provisions for movement are in line with current standards. Buildings built before 1992 may have stairs with less allowance for inter-storey movement than currently required.
 - b. That support and separation details are such that they are not compromised by unintended restrictions to movement under earthquake actions.
 - c. That progressive collapse is avoided.
 - d. That appropriate allowances are made for normal variations in construction dimensions.
- 2 *Walls and columns*: A review is needed of some aspects of the requirements for the design, detailing and construction of walls and columns. Improvements in ductility, capacity and confinement steel may be needed to maintain load-carrying capacity in the face of unexpectedly large displacements and/or high vertical accelerations.

Changes in design requirements need to be considered, including the following:

- a. Further limitation on axial loads in columns and walls.
- b. More stringent detailing for ductility, whether or not walls or columns are intended to be part of the earthquake-resisting structure.
- c. Confinement, slenderness and reinforcement requirements for structural walls.

- d. The required detailing of walls subject to flexural yielding, particularly those with variable and/or high axial loads.
- 3 *Earthquake-prone buildings:* There is a need to improve public awareness that buildings which are not classified as earthquake-prone under the Building Act 2004 could also collapse in a major earthquake. Changes in approach should be considered that would promote early action to improve the seismic performance of existing buildings that are not up to current standards. Specific recommendations on this matter are given below under section 8.4.
- 4 *Lightly-reinforced shear walls:* Reinforced concrete shear walls like those in the PGC Building are particularly vulnerable in severe earthquake shaking. Usually the reinforcing steel is a central layer and there is no confining steel². This type of construction could have been used in buildings built before 1965 and possibly as late as 1976. Such buildings are not usually classified as earthquake-prone under the Building Act 2004.

Owners of buildings built before 1976 need to be alerted to this vulnerability and urged to obtain advice from a Chartered Professional Engineer with experience in structural design.

Consideration needs to be given to these vulnerabilities in the New Zealand Society for Earthquake Engineering assessment guidelines.

8.4. Other recommendations

- 1 *Structural irregularity:* There is a need for greater design rigour for buildings with irregularity (horizontal or vertical) resulting from architectural requirements. While current design standards impose stricter requirements for irregular structures, greater recognition is needed of the special demands on critical members that can result from structural irregularity. There is a need to detail these members accordingly.
- 2 *Displacement demand:* In the design of new buildings, and the assessment of existing buildings, greater emphasis should be placed on the displacement demands on the structure and the capacity of the structure to accommodate those demands. There is a need for increased design rigour for displacement-induced actions. For example, greater attention is needed to detail secondary (i.e. non-seismic) structural elements to withstand the induced displacements that may occur during seismic actions.
- 3 *Progressive collapse:* Failures of the stairs in the Forsyth Barr Building and the Hotel Grand Chancellor underline the need for more rigorous approaches to avoid progressive collapse due to the failure of one member. Consideration should be given to requiring designers to identify the measures taken to avoid progressive collapse.
- 4 *Cantilevers and vertical accelerations:* The high demands on the failed shear wall in the Hotel Grand Chancellor and the recording of high vertical accelerations is a

² Confining steel is used in modern reinforced concrete columns and beams. Properly applied, it can produce very large increases in the load carrying-capacity of these members *and* their ability to retain that capacity as they deflect. The confining steel acts in a similar way to the hoops on a wine cask. Structures built before 1976 were not required to have confining steel.

reminder that the design of cantilevers requires consideration of vertical accelerations.

- 5 *Stair supports:* Changes in approach to stair support design are required. Stair supports must be designed to have a sufficient displacement capacity so that stair collapse is not expected to occur before building collapse. This will require allowances for displacements well above those expected at the ultimate limit state of the structure.
- 6 *Structural integrity:* Greater emphasis on overall structural integrity is needed, including the following:
 - a. Methods for determining the required connection forces between the floor diaphragm and structural walls and shear cores should be re-examined.
 - b. Design and design reviews need to focus more on the detailing necessary to achieve structural integrity (tying together of main structural elements).
 - c. Columns, beams and joints must be detailed to achieve a high degree of resilience.
- 7 *Earthquake prone buildings:* The consultant's finding that the PGC Building could have been classified as earthquake-prone has caused the Panel to consider the need for changes in the legislation on earthquake-prone buildings. The Panel recognises that this topic will be covered by the Royal Commission, and across a wider range of buildings, and that it is strictly outside the Panel's terms of reference, but the Panel makes the following observations aimed at effecting improvements:
 - a. The level of 33% of New Building Standard (NBS) used in regulations to the Building Act 2004 to define an earthquake-prone building, has been wrongly interpreted as meaning that buildings above this level are relatively safe in a major earthquake. This is in spite of clear messages to the contrary that the legislation was set to cover only the worst of buildings.
 - b. Action is needed to address this misunderstanding. Strong education initiatives are needed to improve public awareness of the danger represented by older buildings which do not meet current design requirements.
 - c. The Panel believes that consideration should be given to promoting measures that would develop a stronger appreciation of the value of good seismic performance of buildings, and so lead to more improvement action.
 - d. Consideration should be given to changing the approaches for defining earthquake-prone buildings and the requirements for their strengthening. Particular consideration should be given to buildings with the potential to fail in a brittle manner.
 - e. Territorial Authorities should consider adopting active policies to identify and deal with earthquake-prone buildings. Policies should promote early action to improve the seismic performance of existing buildings that are not up to current standards.
 - f. Consideration should be given to changes to the Building Act to give Territorial Authorities the power to require earthquake strengthening when significant alterations are made to a building or when significant increases are made to occupancy levels.

List of Report Appendices

Report Appendices:

Appendix A: Panel Members' Biographies.....	54
Appendix B: Information Obtained.....	57
Appendix C: Glossary of terms.....	60

Appendices (Separate Volumes):

PGC 1.	Pyne Gould Corporation Building Consultant Report
HGC 1.	Hotel Grand Chancellor Consultant Report
FB 1.	Forsyth Barr Building Consultant Report

Appendix A. Panel Members' Biographies

Sherwyn Williams (Chair)

Sherwyn Williams has specialised in construction law for over 30 years, mainly in the areas of claims and dispute resolution. He was recommended by the Solicitor-General. He has acted for building and construction companies in respect of projects in New Zealand and overseas, and for a variety of owners, consultants, and industry organisations. Sherwyn has appeared as counsel in numerous court cases and arbitrations, and acts as an arbitrator and an adjudicator under the Construction Contracts Act 2002. He is a member of the Arbitrators' and Mediators' Institute's panel of arbitrators and its list of adjudicators, and a member of Building Disputes Tribunal's panel of principal adjudicators. He is also President of the Society of Construction Law New Zealand.

Nigel Priestley (Deputy Chair)

Nigel Priestley is an eminent structural engineer, based in Christchurch. Nigel is uniquely qualified to provide both an academic and international perspective to the Panel. He has a PhD in Structural Engineering, is a former Professor of Structural Engineering at University of California, San Diego, has extensive international consulting experience and his work has been recognised with appointments and awards in Italy, United States, Argentina, Switzerland and New Zealand. He has published three books on seismic design, which have considerable local and international recognition, and has extensive experience in the assessment of structural failures in earthquakes (Newcastle Working Men's Club, Royal Palm Hotel in Guam, and various review panels post-Loma Prieta and Northridge earthquake).

Helen Anderson

Helen Anderson is an independent director of DairyNZ, BRANZ and NIWA, and she is Chair of FulbrightNZ. She was Chief Executive of the Ministry of Research, Science and Technology for six years and before that was MoRST's Chief Scientific Adviser for more than five years. Helen has a PhD in seismology from the University of Cambridge. In 2009 Helen was elected as a Companion of the Royal Society of New Zealand. She is also a Companion of the Institute of Professional Engineers of New Zealand, and in 2010 she was appointed a Companion of The Queen's Service Order.

Marshall Cook

Marshall has over 40 years experience working within New Zealand, Australia, North America, Japan, Thailand and the Pacific Islands as an Architectural Consultant, Designer, Urban Planner and Educator. His involvement in a wide range of building types, construction methodology and international practices as well as a deep interest in material and structural performance has underpinned his professional practice and teaching career. He is currently an adjunct Professor of Design at Unitec, a member of the registered Architects Board and has served on the N.Z.I.A. National Council for several years. Recently awarded the N.Z.I.A. Gold Medal for services to architecture. He is also a Fellow of the Institute and recipient of the President's Award.

Peter FehI

Peter FehI has spent most of his working life associated with the construction industry. The earlier years were spent on major civil engineering and commercial construction projects, both for himself and other major contractors, in various site and management positions. Peter has brought to the Panel expertise in the practices of the construction industry at the time these buildings were constructed.

Clark Hyland

Clark has twenty five years experience in structural engineering. Half of that time has been in consulting engineering and the remainder for the New Zealand Heavy Engineering Research Association and Steel Construction New Zealand. He currently runs a consulting engineering company specialising in fatigue and earthquake engineering. He gained a PhD at the University of Auckland and has been Chairman of the New Zealand Steel Structures Standard Committee.

Rob Jury

Rob Jury graduated with a Masters in Civil Engineering from the University of Canterbury in 1978. A Technical Director in Beca's Wellington office, a Chartered Professional Engineer, and a Fellow of both the Institution of Professional Engineers and the New Zealand Society for Earthquake Engineering (NZSEE), Rob is one of New Zealand's most experienced earthquake engineers. He was a member of the committee that developed New Zealand's current earthquake loadings Standard, and chairman of the NZSEE's Earthquake Risk Buildings study group that produced the current guidelines for the Assessment and Improvement of the Structural Performance of Buildings in Earthquakes. One of the many significant structures for which he has led the structural design is Auckland's Sky Tower.

Peter Millar

Peter Millar is a leading geotechnical engineer, and was Managing Director of Tonkin and Taylor (New Zealand's leading geotechnical consultancy, who provided services to EQC on liquefaction following the 4 September 2010 earthquake). He has brought to the Panel expertise in geotechnical issues and foundation design.

Stefano Pampanin

Stefano Pampanin is Associate Professor in Structural Design & Earthquake Engineering and Chair of the Structures/Geotechnical Cluster at the Department of Civil and Natural Resources Engineering at the University of Canterbury. He received a Masters in Structural Engineering at University of California at San Diego and a Ph.D. in Earthquake Engineering from the Technical University of Milan. His research and professional activities (Chartered Professional Engineer in Italy and New Zealand) have focused on the development and implementation of innovative solutions for the design of low-damage earthquake-resistant systems and the retrofit of existing structures. He is the author of more than 200 scientific publications and has received several national and international awards for his research and development achievements.

George Skimming

George Skimming is currently Director Special Projects at Wellington City Council. George has brought to the Panel expertise in the consenting practices at the time the buildings were constructed.

Adam Thornton

Adam Thornton is Managing Director of Dunning Thornton Consultants Ltd, a specialist structural/seismic engineering consultancy operating from Wellington, New Zealand. He is a Chartered Professional Engineer and a Fellow of The Institution of Professional Engineers of New Zealand. He has over 35 years structural engineering design experience and has specialised in high-rise seismic design, the seismic retrofit of heritage and earthquake-prone buildings and the relocation of concrete and masonry buildings. He led the structural engineering team for the \$350m New Wellington Regional Hospital. Adam is a Past-President of the Association of Consulting Engineers of New Zealand and a past member of the IPENZ Practice Board. He is currently a board member (and Treasurer) of

FIDIC – The International Federation of Consulting Engineers. He has represented engineers in a number of forums and has presented widely.

Consulting engineers involved in specific building investigations:

Beca

Beca Carter Hollings & Ferner Ltd is part of the Beca group (www.beca.com) which is a New Zealand-headquartered professional services organisation specialising in the design and management of projects. Beca is owned by its senior staff, and has more than 2500 employees who have operated in more than 70 countries from its three key market hubs of New Zealand, Australia and Singapore. Beca has a long history of participation in the development of design codes for the earthquake resilience of structures. Its earthquake engineering specialists have written and/or reviewed the codes for countries as diverse as Indonesia, Nepal, Papua New Guinea, Turkey and Romania, as well as contributing to New Zealand's codes over many years. Beca engineers have designed many of New Zealand's major office buildings, industrial structures and bridges.

Dunning Thornton Consultants

Dunning Thornton Consultants [DTC] are a niche structural engineering consultancy specialising in complex structural and seismic projects. Founded in 1979 they have developed a reputation for innovative, award winning projects and the ability to solve complex problems. They have led the implementation of new, damage-limitation technologies in New Zealand and have become well known for their effective but sensitive seismic retrofit of heritage structures. They are respected by both clients and builders for their practical, solution-based approach to structural engineering. Based in Wellington they carry out work throughout the country and occasionally internationally.

Hyland Consultants Ltd / StructureSmith Limited

Hyland Consultants is a specialist consulting engineering firm based in Auckland that focuses on fatigue and earthquake engineering of structures.

StructureSmith Ltd is a specialist structural engineering consultancy with specialist expertise in analysis of complex structures; earthquake engineering design and evaluation; assessment and strengthening of existing buildings; forensic engineering and problem solving, and building failure investigation.

Appendix B. Information Obtained

List of information obtained in the course of investigation includes:

General Information	
Source	Information Provided
University of Canterbury Reports	<ul style="list-style-type: none"> • Prelim Report April 2011 - Seismic Performance of Pre Cast Concrete Staircase Systems after 22 Feb earthquake (by Stefano Pampanin and Weng Yuen Kam) • Prelim Report March 2011 - The Seismic Performance of Reinforced Concrete Buildings Built 1930s – 1970s in the Christchurch CBD after the 22 Feb earthquake (by Stefano Pampanin et al) • 2011 PCEE Paper – Considerations on the seismic performance of pre-1970s RC buildings in the Christchurch CBD during the 4 Sept 10 earthquake: was that really a big one? (by Stefano Pampanin et al) • Prelim Report April 2011 – Pyne Gould Corp (PGC) Building 233 Cambridge Terrace post 22 Feb 2011 (by Stefano Pampanin and Weng Yuen Kam) • Lateral Spreading Assessments Feb 2011
Seismology / Earthquake Records	<ul style="list-style-type: none"> • GNS Science Earthquake Records 4 Sept 10 • GNS Science Earthquake Records 26 Dec 10 • GNS Science Earthquake Records 22 Feb 11 • A New Seismic Hazard Model for New Zealand (by Mark W. Stirling, Graeme H. McVerry and Kelvin R Berryman) • 2003 PCEE Paper – From hazard maps to code spectra for New Zealand (by G. H. McVerry)
Ground Condition / Borelogs	<ul style="list-style-type: none"> • Borelog information <ul style="list-style-type: none"> ○ Borelog Plan 3 – 20/4/60 ○ Borelog Plan 4 – 20/4/60 ○ Borelog Plan 5 – 20/4/60 ○ Borelog – 233 Cambridge Tce #1 ○ Borelog – 233 Cambridge Tce #2 ○ Borelog – 208 Cambridge Tce ○ Borelog – 106 Gloucester St ○ Borelog – 746 Colombo St ○ Borelog – 253 Cambridge Tce ○ Borelog – Manchester St – Cambridge Tce – Bank of River ○ Borelog – 305 Manchester St Crown of Road ○ Borelogs near PGC & Forsyth Barr ○ Borelogs – CBD ○ Borelogs - Medium zoom ○ Borelogs – Large zoom

Building Specific Information	
Source	Information Provided
PGC Building	<ul style="list-style-type: none"> • Christchurch City Council Building Files, PGC Building 233 Cambridge Tce. Post 4 Sept 10 files received as available • Complete structural drawings set • PGC 1997 Seismic Evaluation of Building by engineers • PGC 2007/08 Alterations and Options by engineers • Prelim Report April 2011 – Pyne Gould Corp (PGC) Building 233 Cambridge Terrace post 22 Feb 2011 (by Stefano Pampanin and Weng Yuen Kam) • Police photos • USAR photos • Forensic Site Examination and Materials Testing after 22 Feb 11 aftershock: <ul style="list-style-type: none"> ○ Concrete Core Tests ○ Reinforcing Steel Tests • Public evidence <ul style="list-style-type: none"> ○ Accounts of the state of the building prior to 22 Feb 11 ○ Witness accounts of building collapse ○ Tradespeople who worked on the building ○ Photos received <ul style="list-style-type: none"> ▪ Prior to 22 Feb 11 ▪ Showing damage to buildings following 4 Sep 10 earthquake ▪ Immediately following 22 Feb 11 aftershock showing collapsed building ▪ During construction in 1987 • Interviews with PGC Building tenants • Interview with PGC Building owner • Interviews with USAR engineers
Grand Chancellor Hotel	<ul style="list-style-type: none"> • Christchurch City Council Building Files, 145 Cashel St and 161 Cashel St. Post 4 Sept 10 files as available also received for 161 Cashel St. • Complete structural drawings set, original design and alterations. • Seismic Inspection Report by engineers after 4 Sep 10 earthquake • Hotel Grand Chancellor 1988 Development Report by engineers • USAR photos • Post 4 Sept 10 Earthquake Damage Report by engineers • Post 26 Dec 10 Earthquake Damage Report by engineers • Post 22 Feb 11 Earthquake Damage Report by engineers • Public evidence <ul style="list-style-type: none"> ○ Accounts of the state of the building prior to 22 Feb 11 ○ Photos received <ul style="list-style-type: none"> ▪ Prior to 22 Feb 11 ▪ Showing damage to building following 4 Sep 10 earthquake ▪ Showing damage to building following 22 Feb 11 earthquake • Interview with USAR engineers

Forsyth Barr Building	<ul style="list-style-type: none"> • Christchurch City Council Building Files, Forsyth Barr Building 764 Colombo St and 114 Armagh St. Post 4 Sept 10 files received for 764 Colombo St as available • Structural drawing set • Forsyth Barr Post Sept 10 Earthquake and Repair Reports by engineers • Forensic Site Examination and Materials Testing after 22 Feb 11 aftershock: <ul style="list-style-type: none"> ○ Concrete Core Tests ○ Reinforcing Steel Tests • USAR photos • Interview with Forsyth Barr Building owner • Interview with USAR engineers • Interviews with Forsyth Barr Building tenants • Public evidence <ul style="list-style-type: none"> ○ Accounts of the state of the building prior to 22 Feb 11 ○ Photos received <ul style="list-style-type: none"> ▪ Prior to 22 Feb 11 ▪ Showing damage to building following 4 Sep 10 earthquake ▪ Showing damage to building following 22 Feb 11 aftershock
Other Information	
Source	Information Provided
Media	<ul style="list-style-type: none"> • Daily Media Monitor Reports • Footage from TVNZ • Broadcast summaries

Appendix C. Glossary of terms

Acceleration response spectra – Plot (graph) showing peak building accelerations relative to the fundamental period of the building.

Axial loads – A pure tension or compression load acting along the long axis of a structural member (e.g. a beam or column).

Axial capacity – Maximum *axial load* that can be carried without failure.

Base shear – Base shear is an estimate of the maximum expected lateral force that will occur due to seismic ground motion at the base of a structure. [The base shear is a summation of the individual shears occurring at each floor level and is determined from a number of factors including the weight of the building, the site's earthquake intensity, the ground conditions, and the building's structural characteristics.]

Biaxial bending – Bending of a structural member about two perpendicular axes at the same time.

Cantilever structure – A structure that is supported at one end only and that support provides full fixity.

Capacity – Overall ability of a structure or structural member to withstand the imposed demand.

Capacity design – A design process which limits forces in some structural members in order to protect others. E.g. the weak beam /strong column approach protects columns.

Catenary – A curve formed by a chain or rope hanging freely from two points.

Centre of rigidity – If load is applied at a building's centre of rigidity, the building will not rotate or twist.

Compression failure – Failure of a structural member that occurs when its *axial capacity* in compression is exceeded.

Confined concrete – Concrete which is restrained by transverse reinforcement (i.e. reinforcement at right angles to the principal reinforcement e.g. stirrups around a column or beam's longitudinal reinforcement) from bursting outwards (like hoops on a barrel).

Critical capacity ratios – The ratio of the building's or structural member's capacity to the *demand* placed on it, at which failure occurs.

Demand – A generic term to describe structural actions caused by gravity, wind, earthquake, and snow, acting on a structure.

Damped horizontal acceleration – Horizontal accelerations in a building subjected to the building's *damping*.

Damping – Damping is the process by which energy in a vibrating system is absorbed causing a decaying trend in the system's response. Damping in buildings is caused by a variety of factors including internal material energy dissipation effects, friction between components and drag.

Dead load – The self weight of the building exclusive of any applied load.

Deflection – *Displacement* measured from an at-rest or agreed starting position.

Deformation – Deformation in a structural or other member is a change in the original shape of the member. Deformation in a building occurs when it deflects or otherwise reacts to applied load.

Design capacity ratios – The ratio of estimated (load) *capacity* to the (load) demand as used for design purposes.

Design (or response) spectra – Graphical relationship of maximum response of buildings to dynamic motion or forces. The most usual measures of response are maximum *displacement*, velocity and acceleration relative to the natural period of vibration of the building.

Displacement – Displacement is the difference between the initial position of a reference point and any later position. The amount any point affected by an earthquake has moved from where it was before the earthquake.

Displacement response spectra – Plot (graph) showing peak building *displacements* of the centre of gravity of a building in response to a specified ground motion.

Double-tee – A structural member, normally of pre-cast concrete and used horizontally, that has the configuration of two adjacent capital 'Ts'.

Drag members – Structural members that transfer lateral loads from a floor slab to the building's seismic resisting elements (usually a frame of columns and beams).

Ductile – See '*Ductility*'.

Ductility – The ability of the structure or element to undergo repeated and reversing *inelastic deflections* while maintaining a substantial proportion of its initial load carrying *capacity*. The benefits of *ductile* design are that the building can be designed for lateral forces less than those required for *elastic* response. Further, the building is likely to remain standing or at least not suffer a brittle and sudden failure if it is subjected to an earthquake larger than the design earthquake.

Dynamic – Things that change with time e.g. dynamic loads.

Earthquake – A term used to describe both sudden slip on a fault and the resulting ground shaking and radiated seismic energy caused by the slip.

Earthquake-prone – Defined term in Building Act 2004 describing a building that would be likely to collapse in a moderate *earthquake* (one-third the intensity of shaking used for a new building). Ref S122 of Building Act 2004.

Eccentricity – A measure of the distance from the point of load application to the *centre of rigidity*. The greater the eccentricity, the greater the rotation.

Egress – Way out or exit.

Elastic – Structural behaviour where an element or part springs back to its initial position when load is removed (no energy is absorbed in the process).

Epicentre - The epicentre is the point on the earth's surface vertically above the focus point in the crust where a seismic rupture begins.

Fixity – Measure of the amount of rotation in a structural member allowed at the support point. A cantilever which by definition has full fixity has no rotation at the face of its support. A pin (or roller or hinged) support provides no fixity and allows the structural member to rotate freely at the face of the support under applied load.

Flexure – Bending under load.

Flexural cracking – Cracking as a result of *flexure*.

Flexural-torsional buckling – Failure of a structural member resulting from simultaneous torsion (twisting) and *flexure* (bending).

Flexible soils – Soils which deflect more than usual under load.

Floor diaphragms – Broad horizontal structural floor members (e.g. concrete slabs) that carry horizontal load to the building's seismic resisting elements (e.g. frame or shear wall).

Geotechnical – Referring to the use of scientific methods and engineering principles, to acquire, interpret, and apply knowledge of earth materials for solving engineering problems.

Ground motion – The movement of the earth's surface from earthquakes. Ground motion is produced by waves that are generated by a sudden slip on a fault and travel through the earth and along its surface.

Hinge zone – That portion of a structural member which undergoes *inelastic deformations*.

Hollow-core – A term that refers to a pre-cast concrete slab unit that has hollow cores along its length to reduce its weight.

Horizontal shear – *Shear* in a horizontal direction.

Inelastic – The member or element goes beyond its elastic limit (it does not return to initial position and energy is absorbed).

In-plane – Along the face of, or parallel to, the structural member under consideration.

In-situ concrete – Concrete poured on site.

Inter-storey drift – Horizontal displacement of a floor relative to the floor immediately below.

Kilopascals (kPa) – Measurement of pressure being equal to one thousand Pascals. A Pascal being the pressure resulting from the force of one Newton applied over an area of one square metre.

Lap zone – Zone where reinforcement is overlapped so as to maintain its structural continuity.

Lateral displacement – Movement in a sideways or horizontal direction.

Lateral resilience – Ability of a structure to withstand lateral actions.

Lateral spreading – Horizontal movement of the ground as a result of *liquefaction*.

Liquefaction – Loss of resistance to shear stress of a water-saturated, silty-sandy soil as a consequence of earth shaking, to the extent that the ground behaves as a liquid rather than a solid.

Liquefaction ejecta – Soil that has been pushed up and ejected at the ground surface as a result of *liquefaction*.

Linear (refer to Elastic)

Linear static analysis – Another term for ‘equivalent static analysis’.

Live load – The applied load or weight borne by a structure.

Mercalli Scale – A 10-degree scale that measures *earthquake intensity* by examining its effects on the Earth's surface, humans, objects of nature, and man-made structures. Mercalli, an Italian seismologist, developed the scale in the early 20th century. Since that time it has been modified several times, and is known today as the *Modified Mercalli Scale*. Referred to as MM or MMI (Intensity).

Modal analysis – Analysis of the building that considers and combines the various modes of vibration to determine the building's total response.

Moment demands – The flexural demands on a structural member.

Moment frame – A structural frame which resists applied loads, primarily in bending or *flexure*.

Moment-resisting – Able to resist the *moment demands* placed on it.

Non-ductile – Prone to sudden or brittle failure.

Non-linear – Describes behaviour beyond *linear* (or *elastic*).

Out-of-plane – At right angles to the face of, or perpendicular to, the structural member under consideration.

P-delta effects – Destabilizing effects due to (significant) horizontal *displacement* of the centre of gravity of a structure (e.g. from an earthquake). When a structure is displaced, P-delta effects reduce the resistance of the structure to further

displacement in the same direction. P-delta effects are important considerations in *ductile* (flexible) structures.

Performance-based design – Design that meets nominated building performance criteria.

Planar – In the plane of, or parallel to, the structural member.

Pounding – Effect of two objects (buildings) impacting against or striking each other.

Pre-cast concrete – Concrete poured at a location remote from the building site and later transported to and placed on the site.

Response spectra analysis – Structural analysis using response spectra derived from specified ground motions.

Retrofitting – Reinforcement or strengthening of existing structures to become more resistant and resilient to earthquakes.

Sand boil – A sand boil is sand and water that come out onto the ground surface during an earthquake as a result of *liquefaction*.

Section capacities – The limiting (maximum) actions (bending, *shear* and *axial load*) that a structural member (e.g. beam or column) can withstand without failure.

Seismic frame – A frame, comprising columns and beams, that contributes to the building's lateral resistance enabling it to withstand earthquake actions.

Seismic gap – A separation between buildings or building elements which allows them to move during earthquakes.

Seismic response spectra – See *Response spectra*.

Seismicity – Refers to the geographic and historical distribution of earthquakes and their effects.

Shear – A force applied at right angles to a main axis of a building or structural member.

Shear wall – A wall that contributes to the building's lateral resistance enabling it to withstand earthquake actions.

Shear wave velocity – The velocity of a shear wave (being one type of ground wave generated by an earthquake). Shear waves are transverse waves with particle motion perpendicular to the direction of wave propagation. Shear waves can be destructive because of their larger amplitudes.

Spalling – The loss of cover concrete, being the concrete between the external face of a structural member (e.g. beam or column) and the main reinforcing steel.

Spandrel panels – Panels on the external face of the building. Spandrel panels normally extend from ceiling level on one floor to window sill height on the floor above. Spandrel panels are often used to provide fire separation between floors but can also have a structural function or comprise part of the building's cladding.

Tensile – Relates to tension in a structural member.

Tensile failure – Failure of a structural member as a result of tension.

Torsion – Twisting of a structural member or building as occurs when loads are applied other than through the member or building's centre of rigidity.

Transfer beams – Structural members that transfer lateral loads at floor slab level to the building's seismic resisting elements (e.g. to its seismic frame or shear wall).

Vertical acceleration – Earthquake acceleration measured in the vertical direction.

Wall fins – Structural members at right angles to a wall to provide lateral stability.

Yielding – Deforming under constant load.