



Department of
Building and Housing
Te Tari Kaupapa Whare

Energy Efficiency of Buildings:

Consultation on revisions to Compliance Documents including: a new Acceptable Solution for Solar Water Heating (G12/AS2) and amendments to G12/AS1

Closing date for public comment: 26 September 2007

New Zealand Government

Published in September 2007 by
Department of Building and Housing
PO Box 10-729
Wellington
New Zealand

This document is also available on the Department's website:
www.dbh.govt.nz/energy-efficiency

ISBN: 978-0-478-19440-1 (document)
ISBN: 978-0-478-19441-8 (website)

Contents

Request for Comment	4
How to comment	4
Important Note	4
Executive summary of the proposal	5
A new Acceptable Solution for Solar Water Heating	5
1 General Reasons for the proposal	6
2 Changes from the 2006 consultation	6
2.1 Installation	6
2.2 Protection from Legionella bacteria	7
2.3 Revised G12/AS1	8
3 Transitional arrangements	8
4 Proposed changes to Acceptable Solution G12/AS1	8
5 Proposed Accepted Solution G12/AS2	10

Request for comment

The Department of Building and Housing seeks feedback on the proposed new Acceptable Solution for solar water heating installations described in this document (G12/AS2), as well as on proposed amendments to G12/AS1.

All submissions received by the Department will be carefully considered before a final decision is made on the proposals contained in this document.

Comments can be submitted on individual topic areas.

How to comment

Please submit your comments in writing. Typed comments are preferred, but clear handwriting will be accepted. You can return comments by letter, fax or email. Additional copies of this document can be downloaded as a PDF from the Department's website at

<http://www.dbh.govt.nz/energy-efficiency>

They can also be obtained by calling the Department on 0800 242 243.

The closing date for submitting comments on the proposed changes is 26 September 2007

They need to be sent to:

Consultation Feedback – Solar water heating
Department of Building and Housing
Building Controls
PO Box 10-729
Wellington
New Zealand

or emailed to comments@dbh.govt.nz. Please put 'Consultation Feedback – Solar water heating' in the subject line

or faxed to (04) 494 0290.

Important note

Please note that all responses will be public information. Responses may be the subject of requests for information under the Official Information Act 1982 (OIA). The OIA specifies that information is to be made available to requesters unless there are sufficient grounds for withholding it, as set out in the OIA. Submitters may wish to indicate grounds for withholding specific information contained in their submission, such as that the information is commercially sensitive or that they wish personal information to be withheld. Any decision to withhold information requested under the OIA is reviewable by the Ombudsman.

Executive summary of the proposal

A new Acceptable Solution for solar water heating

At the end of 2006, the Department undertook a public consultation on a package of proposed changes relating to Building Code Clause H1 'Energy Efficiency' including a solar water heating proposal.

The proposal involved producing a new Acceptable Solution for the solar water heating, to be included in the Clause G12 'Water Supplies' Compliance Document as G12/AS2. The lack of comprehensive guidance on solar installations in the Building Code compliance Documents has meant that there is no clear path to Code compliance for solar installations. Building consent authorities have to look at each installation on its merits and this can be time-consuming. For installation companies, there is no certainty about Code compliance.

The proposals under Clause H1 have been refined following the consultation and are proceeding through to the publication stage. The draft solar G12/AS2 has undergone a complete revision because of the need to include new requirements to ensure the weathertightness and durability requirements of the Building Code are satisfied. The recent report by BRANZ entitled 'An Inspection of Solar Water Heating Installations' indicated that significant number of installations could have a detrimental effect on roof durability and weathertightness. There were also questions about the safety of some installations in terms of their ability to handle overheating and overpressure.

The Department has worked with the solar industry and the metal roofing industry to address the installation quality issue and to develop practical solutions. For the growth and long term success of the solar industry there must be clear methods of Code compliance giving public confidence in the way solar systems are installed.

Another issue to be resolved was the potential hazard of legionella bacteria in hot water systems. Legionella bacteria can cause death when inhaled (eg in the water droplets in a shower). The bacteria breed in water at temperatures in the 20 – 45^o C range. A report was commissioned from ESR, a scientific research organisation, to help define the particular risks presented by solar systems. The report has enabled heating regimes to be specified that will ensure low levels of legionella bacteria in solar boosted hot water systems.

The production of a another Acceptable Solution for inclusion in the G12 Compliance Document as G12/AS2 has meant that some corresponding changes are needed to the existing G12 Acceptable Solution (G12/AS1) to ensure the two documents are aligned. The draft revised G12/AS1 is part of this consultation.

Finalising G12/AS2 has also been dependent on publication of a key reference Standard. G12/AS2 makes reference to AS/NZS 2712, the Standard for the design and construction of solar hot water heaters. This Standard is used by the industry in both countries, and was developed as a joint Standard because Australian solar products are widely sold in NZ. The Standard has been under review (with several committee members from NZ). However, publishing of the new 2007 version by Standards Australia was delayed several months and has only now become available.

1 General reasons for the proposal

In October 2006, the Minister for Building Issues, Hon Clayton Cosgrove MP, announced a package of initiatives to improve the energy efficiency of new and existing homes and commercial buildings, and to reduce their energy demand and associated greenhouse gas emissions.

The Minister's announcement identified five areas of priority for inclusion into the package of initiatives. These are:

- increasing the performance requirements for thermal insulation in new houses
- improving the documentation that helps solar water heating installations demonstrate compliance with the Building Code, and investigating how to improve hot water systems for increased energy effectiveness and efficiency
- increasing the performance requirements for lighting systems in commercial buildings
- improving the performance requirements for heating, ventilation and air-conditioning (HVAC) systems in commercial buildings.
- Improving the performance requirements for domestic water heating.

This document contains specific proposals for solar hot water heating installations. The other priority areas are being dealt with separately.

The Department considers the proposals an important step in improving the quality of New Zealand homes and buildings, and contributing to the Government's energy efficiency and climate policy goals.

The proposals are aligned with work that is being undertaken by other government agencies. This includes the EnergyWise home retrofit programme and the programme for assistance with solar hot water installations by the Energy Efficiency and Conservation Authority as well as the Warm Homes initiative by the Ministry for the Environment. The proposals are part of a coordinated, multi-agency effort to meet the Government's energy efficiency and climate change objectives.

2 Changes from the 2006 consultation

2.1 Installation

The 2006 draft covered the strengthening of existing roofs to carry the additional weight of coupled collectors and hot water containers. The weights of these containers can be upwards of 400 kg. The necessary roof strengthening, and the connections to resist seismic and wind loads, can be quite complex. The Department decided that it was not practicable to attempt to give strengthening methods that would be applicable to the wide range of roof types and constructions that occur throughout the country. The installation of a hot water container on a building therefore means the strength of that particular roof structure will first need to be examined and a method of installation developed to resist the foreseeable loads and forces imposed by the container.

The BRANZ study of solar installations indicated that there was a lack of knowledge about the compatibility of different materials used in situations exposed to the weather. Electrochemical action producing corrosion, particularly where zinc coatings and copper are involved, can be rapid. Stainless steel is not compatible with all roof materials. The 2007 draft of the Acceptable Solution gives tables of material compatibility and indicates when water flow from one material to another is acceptable.

The need for guidance on fixing of collectors to roofs became apparent during the 2006 consultation, and the BRANZ study reinforced this need. Direct contact between collectors and metal roofing is very likely to result in corrosion and premature failure of the roofing material. Metal roofing is not designed to carry direct loads and so the most satisfactory method of installing collectors is to transfer the load through to the underlying structure. This can be done by setting the collector into the roof, in a similar manner to the installation of a skylight, or by having point supports that carry the load to the roof structure. These point penetrations can be made weathertight using conventional roofing methods. The 2007 draft now gives several types of point support, and the Department expects that the solar industry will develop its own methods to achieve the same result. They can be evaluated by territorial authorities as 'alternative solutions'.

2.2 Protection from Legionella bacteria

The Building Code contains the provision:

G12.3.9 A *hot water system* must be capable of being controlled to prevent the growth of legionella bacteria.

One way of complying with the Building Code for water supplies is to use the G12 'Water Supplies' Compliance Document, which is published by the Department. G12/AS1 of the Compliance Document has the storage of hot water at temperatures greater than 60°C as the mechanism for preventing the growth of Legionella bacteria.

Solar hot water systems, where the energy for heating the water comes from the sun and hence may vary due to the time of day or the time of year, may not routinely heat the water to 60°C. Research into the growth of Legionella in domestic hot water systems, including solar heated water systems, found that:

- Legionella will grow in domestic hot water systems
- There is significant under reporting of legionellosis cases as clinically it can present as a self-resolving flu-like illness, and is unlikely to be confirmed by laboratory testing
- Even where the illness does not result in a death, there is still significant health and social cost incurred
- Heat disinfection is the most cost effective way to mitigate against the risk of Legionella growing in domestic hot water systems.
- In a Wellington study, 100 electrically heated domestic hot water systems were tested for Legionella and while no live bacteria were cultivated, evidence of Legionella was present in 6 to 12 % of the systems.
- Internationally there is concern about the growth of legionella in domestic hot water systems and research continues into ways to reduce the health risk.

The Energy Efficiency and Conservation Authority (EECA) commissioned a study by an ESR scientist to specifically assess the potential hazard of Legionella in solar boosted hot water systems in New Zealand. The ESR report established that, while the risk is low, it should not be ignored. ESR made proposals for controlling the growth of the bacteria in solar hot water systems.

2.3 The revised G12/AS1

The amendments proposed for G12/AS1 are mainly to bring it into alignment with the proposed G12/AS2, particularly in terms of the referenced Standards and Legionella protection.

3 Transitional arrangements

The Department proposes to include the new solar Acceptable Solution G12/AS2 and the amended G12/AS1 in the Clause G12 Compliance Document. When the amended version of AS/NZ 3500.4 is published, it will be considered by the Department for adoption as the referenced Standard to replace the 2003 version.

The Department expects the Solar Acceptable Solution to be published in October. There will be a 3 month transition period before it becomes effective. However, because it does not replace an existing document, it could be considered as an 'alternative solution' by territorial authorities as soon as it is published.

4 Proposed changes to Acceptable Solution G12/AS1

Current text	Proposed change
References NZS 4613: 1986 Domestic solar water heaters AS 2712: 1993 Solar water heaters – Design and construction	References NZS 4613: 1986 Domestic solar water heaters (until 01 July 2008) Deleted AS/NZS 2712: 2002 Solar and heat pump water heaters – design and construction (until 01 July 2009) AS/NZS 2712: 2007 Solar and heat pump water heaters – design and construction

<p>Table 5</p> <p>Water heater type Standard/Regulation</p> <p>Solar storage NZS 4613 water heater AS 2712</p>	<p>Table 5</p> <p>Water heater type Standard/Regulation</p> <p>Solar storage NZS 4613 (see G12/AS2) water heater AS/NZS 2712 (seeG12/AS2)</p>
<p>6.5.1 Electric thermostats shall comply with NZS 6214 or AS 1308</p>	<p>6.5.1 Electric thermostats and energy cut-off devices shall comply with NZS 6214 or AS 1308</p>
<p>6.9 Alternative acceptable solutions for the installation of open vented storage water heaters</p>	<p>6.9 Another acceptable solution for open vented storage water heaters</p>
<p>6.10 Alternative acceptable solutions for the installation of unvented (valve vented) storage water heaters</p>	<p>6.10 Another solution for the installation of unvented (valve vented) storage water heaters</p>
<p>6.11.5 An alternative acceptable solution for securing <i>storage water heaters</i> against seismic forces in given in Section 203 of NZS 4603</p>	<p>6.11.5 An acceptable solution for securing <i>storage water heaters</i> against seismic forces in given in Section 203 of NZS 4603</p>
<p>6.14.3 Irrespective of whether a mixing device is installed, the <i>storage water heater</i> control thermostat shall be capable of being set at a temperature of not less than 60°C to prevent growth of Legionella bacteria.</p>	<p>6.14.3 Irrespective of whether a mixing device is installed, the <i>storage water heater</i> control thermostat shall be set at a temperature of not less than 60°C to prevent growth of Legionella bacteria.</p>

5 Proposed Acceptable Solution G12/AS2

CONTENTS

Acceptable Solution G12/AS2

- References
- 1 Scope
- 2 Materials
- 3 Solar Hot Water System Requirements
- 4 Location of Solar Hot Water Systems
- 5 Solar Hot Water System Installation Requirements
- 6 Structural Support of Solar Water Heating Systems
- 7 Maintenance and Durability

References

For the purposes of New Zealand Building Code compliance, reference documents include only the quoted edition and specific amendments listed below.

Note: These referenced documents apply specifically to solar installations. Other referenced documents in the G12 Compliance Document will also apply as they relate to plumbing installations in general. The documents listed below will be incorporated in the list of reference documents in the G12 Compliance Document in the published version.

New Zealand Standards

NZS 4203:1992 Code of Practice for general structural design and design loadings for buildings

NZS 3604: 1990 Timber framed buildings

NZS 3604: 1999 Timber framed buildings

NZS 1170 Part 5 Structural Design Actions

NZS 4613: 1986 Domestic solar water heaters

NZS 4614: 1986 Installation of domestic solar hot water heating systems

Australia/New Zealand Standards

AS/NZS 3500: 2003: Part 4 Heated water services

AS/NZS 1170 Parts 0, 1, 2, 3 Structural Design Actions

AS/NZS 2712: 2002 Solar and heat pump water heaters – Design and construction

AS/NZS 2712: 2007 Solar and heat pump water heaters – Design and construction

AS/NZS 4692.2: 2005 Electric water heaters – minimum energy performance standard (MEPS)

Australian Standards

AS 4032.2: 2005 Water Supply – Valves for the control of water supply temperatures – Tempering valves and end of line temperature activated devices

Acceptable Solution G12/AS2

1.0 Scope

.....

1.0.1 This Acceptable Solution applies to solar hot water systems installed in or on new and existing *buildings* with a hot water storage capacity up to and including 700 litres.

1.0.2 Where *buildings* have not been specifically designed to support solar heating systems, paragraph 6 (Structural Support of Solar Water Heating Systems) of this Acceptable Solution can be used for the support and fixing of solar collectors on:

- existing *buildings* that meet the structural requirements specified in any one of the following:
 - (a) NZS 3604:1990
 - (b) NZS 3604:1999
 - (c) NZS 4203:1992
 - (d) AS/NZS 1170 Parts 0, 1, 2, 3 and NZS 1170 Part 5

only when all of the following requirements are met:

- the weight of collector panels including frames, fittings, and heat transfer fluid, has a combined weight of no more than 20 kg per square metre, and
- the hot water storage tank is not installed on or above the roof, and
- the *building* is in a wind zone with wind speeds not over 50 m/s (as defined in NZS 3604), and
- the solar collectors are installed parallel to the roof cladding, and
- the design snow loading for the *building* is less than 0.5 kPa, and
- the roof has a pitch no steeper than 45°.

1.0.3 When any of the requirements described in 1.0.2 are not met then a structural assessment is required.

1.0.4 The structural assessment will determine whether the structure is capable of supporting the additional load of the solar water heating system.

1.0.5 If the structural assessment finds that the existing structure is not capable of supporting the additional load of a solar water heater then specific design is required to strengthen the structure to support the additional load of the system.

1.0.6 Solar hot *water supply systems* must comply with G12/AS1 and the additional requirements of this Acceptable Solution (G12/AS2), together with the requirements of other relevant NZBC clauses.

1.0.7 Text boxes headed 'COMMENT' occurring throughout this document are for guidance purposes only.

1.1 Exclusions

1.1.1 If the solar water heater system includes connection to an application such as: underfloor heating, a swimming pool or any similar application, this Acceptable Solution applies only to the solar heating system and its components and not to the application.

2.0 Materials

2.1 Material Selection

2.1.1 All material used to install the solar *water heater* must be:

- (a) in accordance with the *durability* requirements of NZBC Clause B2, and
- (b) suitable for their use, location and environment as shown in Table 1, and
- (c) compatible with adjoining materials as shown in Table 2, and
- (d) compatible with materials subject to run-off as shown in Table 3.

2.1.2 Table 2 states that “butyl/EPDM” to “steel, galv unpainted” is “not permitted”; however, water flow from small areas of EPDM will not significantly affect the *durability* of the roofing. Therefore it is acceptable to use unpainted EPDM boots with unpainted galvanised steel roofing if:

- (a) the boots are small (for 60mm pipe diameter or smaller), and
- (b) there are no more than 10 boots used on the roof, and
- (c) the boots contain no greater than 15% carbon black.

2.1.3 Either the boots or the galvanised roofing must be painted with a suitable protective coating if:

- (a) the boots are for larger than 60mm pipe diameter, or
- (b) there are more than 10 boots used on the roof, or
- (c) the boots contain more than 15% carbon black.

COMMENT:

Tables 1, 2 and 3 have been reproduced from the Department’s Compliance Document E2/AS1 (Tables 20, 21 and 22).

Table 1: Material selection

This table must be read in conjunction with Table 2 and Table 3.

Material	Exposure	Durability	
		15 yrs	50 yrs
Aluminium, copper, lead, zinc, stainless steel	Hidden	✓	✓
	Exposed to weather	✓	✓
	Sheltered	✓	✓
Aluminium-zinc coated steel AZ150 uncoated, or coated to NZS 4217	Hidden	✓	✓ (2)
	Exposed to weather	✓ (1)	✓ (4)
	Sheltered	✓ (3)	✓ (6)
Aluminium-zinc: AZ150 factory-coated to AS/NZS 2728	Hidden	✓	✓
	Type 4 Exposed to weather	✓	✓ (4)
	Type 5	✓	✓ (3)
	Type 6	✓	✓ (1)
	Type 4 Sheltered	✓ (3)	✓ (6)
	Type 5	✓ (1)	✓ (5)
	Type 6	✓	✓ (3)
Bituminous material, uPVC	Hidden	✓	✓
	Exposed to weather	✓	✗
	Sheltered	✓	✓
Butyl rubber	Hidden	✓	✓
	Exposed to weather	✓	✗
	Sheltered	✓	✗
Galvanized steel Z450 uncoated, or coated to NZS 4217	Hidden	✓	✓ (4)
	Exposed to weather	✓ (3)	✓ (6)
	Sheltered	✓ (5)	✓ (6)
Galvanized steel: Z275 factory-coated to AS/NZS 2728	Hidden	✓	✓
	Type 4 Exposed to weather	✓ (1)	✓ (6)
	Type 5	✓	✓ (4)
	Type 6	✓	✓ (1)
	Type 4 Sheltered	✓ (3)	✓ (6)
	Type 5	✓ (1)	✓ (6)
	Type 6	✓	✓ (4)
FIXINGS: Aluminium, bronze, monel and stainless steel (Types 304 and 316)	*Hidden	✓	✓
	Exposed to weather	✓	✓
	Sheltered	✓	✓
FIXINGS: Hot-dipped galvanized steel to AS/NZS 4680	Hidden	✓	✓ (2)
	Exposed to weather	✓ (2)	✓ (6)
	Sheltered	✓ (4)	✗
Screws to AS 3566: Part 2	Class 3 Hidden	✓	✓ (2)
	Class 4	✓	✓
	Class 3 Exposed to weather	✓ (2)	✓ (6)
	Class 4	✓	✓ (4)
	Class 3 Sheltered	✓ (4)	✗
	Class 4	✓ (2)	✗
LEGEND: ✓ Suitable for <i>durability</i> requirement in all NZS 3604 exposure zones, including sea-spray zones ✗ Not suitable for <i>durability</i> requirement ✓ (no.) Conditionally suitable – refer relevant acceptable zone number * Includes fixings protected by putty and an exterior paint system of primer undercoat and two top coats of paint.			
Acceptable zones as per NZS 3604: (1) Zones 1, 2, 3 and 4 (3) Zones 2, 3 and 4 (5) Zones 3 and 4 (2) Zones 1, 2 and 3 (4) Zones 2 and 3 (6) Zone 3			
Note: <i>Durability</i> may be improved by regular washing of sheltered materials. The term "sheltered" is as defined in NZS 3604, Figure 4.2. The term "hidden" is defined as concealed behind another element that would need to be removed to allow monitoring of performance or maintenance. A hidden <i>flashing</i> may be exposed to H ₂ S in geothermal areas, but not to salt spray in coastal zones. If exposed to salt spray, it is classified as "sheltered".			

Table 2: Compatibility of materials in contact

This table must be read in conjunction with Table 1 and Table 3.

	Aluminium, anodised or mill-finish	Aluminium, coated ⁽¹⁾	Butyl rubber & EPDM	CCA-treated timber ⁽²⁾	Cedar	Cement plaster (uncoated)	Ceramic tiles (cement grout)	Clay bricks (cement mortar)	Concrete old (unpainted)	Concrete green (unpainted)	Copper/brass	Glass	Glazed roof tiles	Lead (including lead-edged) unpainted	Plastics	Stainless steel	Steel, galvanised coil-coated	Steel, galvanised (unpainted)	Zinc	Zinc/aluminium coated ⁽¹⁾	Zinc/aluminium, (unpainted)
Aluminium, anodised or mill-finish	✓	✓	✓	X	✓	X	X	X	✓	X	X	✓	✓	X	✓	B	✓	✓	✓	✓	✓
Aluminium, coated ⁽¹⁾	✓	✓	✓	B	✓	X	X	X	✓	X	X	✓	✓	B	✓	B	✓	✓	✓	✓	✓
Butyl rubber & EPDM	✓	✓	✓	✓	✓	✓	✓	✓	✓	✓	✓	✓	✓	✓	✓	✓	✓	✓	✓	✓	✓
CCA-treated timber ⁽²⁾	X	B	✓	✓	✓	✓	✓	✓	✓	✓	✓	✓	✓	✓	✓	✓	B	X	X	B	X
Cedar	✓	✓	✓	✓	✓	✓	✓	✓	✓	✓	✓	✓	✓	✓	✓	✓	✓	X	X	✓	X
Cement plaster (uncoated)	X	X	✓	✓	✓	✓	✓	✓	✓	✓	✓	✓	✓	X	✓	✓	✓	✓	✓	✓	X
Ceramic tiles (cement grout)	X	X	✓	✓	✓	✓	✓	✓	✓	✓	✓	✓	✓	✓	✓	✓	✓	✓	✓	✓	X
Clay bricks (cement mortar)	X	X	✓	✓	✓	✓	✓	✓	✓	✓	✓	✓	✓	✓	✓	✓	✓	✓	✓	✓	X
Concrete old (unpainted)	✓	✓	✓	✓	✓	✓	✓	✓	✓	✓	✓	✓	✓	✓	✓	✓	✓	✓	✓	✓	✓
Concrete green (unpainted)	X	X	✓	✓	✓	✓	✓	✓	✓	✓	✓	✓	✓	X	✓	✓	X	X	X	X	X
Copper/brass	X	X	✓	✓	✓	✓	✓	✓	✓	✓	✓	✓	✓	B	✓	B	X	X	X	X	X
Glass	✓	✓	✓	✓	✓	✓	✓	✓	✓	✓	✓	✓	✓	✓	✓	✓	✓	✓	✓	✓	✓
Glazed roof tiles	✓	✓	✓	✓	✓	✓	✓	✓	✓	✓	✓	✓	✓	✓	✓	✓	✓	✓	✓	✓	✓
Lead (including lead-edged) unpainted	X	B	✓	✓	✓	X	✓	✓	✓	X	B	✓	✓	✓	✓	B	B	B	B	B	X
Plastics	✓	✓	✓	✓	✓	✓	✓	✓	✓	✓	✓	✓	✓	✓	✓	✓	✓	✓	✓	✓	✓
Stainless steel	B	B	✓	✓	✓	✓	✓	✓	✓	✓	B	✓	✓	B	✓	✓	B	X	X	B	B
Steel, galvanised coil-coated	✓	✓	✓	B	✓	✓	✓	✓	✓	X	X	✓	✓	B	✓	B	✓	✓	✓	✓	✓
Steel, galvanised (unpainted)	✓	✓	✓	X	X	✓	✓	✓	✓	X	X	✓	✓	B	✓	X	✓	✓	✓	✓	✓
Zinc	✓	✓	✓	X	X	✓	✓	✓	✓	X	X	✓	✓	B	✓	X	✓	✓	✓	✓	✓
Zinc/aluminium, coated ⁽¹⁾	✓	✓	✓	B	✓	✓	✓	✓	✓	X	X	✓	✓	B	✓	B	✓	✓	✓	✓	✓
Zinc/aluminium (unpainted)	✓	✓	✓	X	X	X	X	X	✓	X	X	✓	✓	X	✓	B	✓	✓	✓	✓	✓

LEGEND:
 ✓ Materials satisfactory in contact.
 X Contact between materials is not permitted. Minimum gap of 5 mm is required to prevent moisture bridging.
 B Avoid contact in sea-spray zone or corrosion zone 1.

NOTES:
 (1) Coated – includes factory-painted, coil-coated and powder-coated.
 (2) Includes copper azole and copper quaternary salts.

Table 3: Compatibility of materials subject to run-off

This table must be read in conjunction with Table 1 and Table 2.

Material that water flows onto	Aluminium, anodised or mill-finish	Aluminium, coated ⁽¹⁾	Butyl rubber & EPDM	CCA-treated timber ⁽²⁾	Cedar	Cement plaster (uncoated)	Ceramic tiles (cement grout)	Clay bricks (cement mortar)	Concrete old (unpainted)	Concrete green (unpainted)	Copper/brass	Glass	Glazed roof tiles	Lead (including lead-edged) unpainted	Plastics	Stainless steel	Steel, galvanised coil-coated	Steel, galvanized (unpainted)	Zinc	Zinc/aluminium coated ⁽¹⁾	Zinc/aluminium, (unpainted)
Aluminium, anodised or mill-finish	✓	✓	✓	✓	✓	✓	✓	✓	✓	✓	✓	✓	✓	✓	✓	✓	✓	✓	✓	✓	✓
Aluminium, coated ⁽¹⁾	✓	✓	✓	✓	✓	✓	✓	✓	✓	✓	✓	✓	✓	✓	✓	✓	✓	✓	✓	✓	✓
Butyl rubber & EPDM	✓	✓	✓	✓	✓	✓	✓	✓	✓	✓	✓	✓	✓	✓	✓	✓	✓	✓	✓	✓	✓
CCA-treated timber ⁽²⁾	X	X	✓	✓	✓	✓	✓	✓	✓	✓	✓	✓	✓	✓	✓	✓	X	X	X	X	X
Cedar	✓	✓	✓	✓	✓	✓	✓	✓	✓	✓	✓	✓	✓	✓	✓	✓	✓	✓	✓	✓	✓
Cement plaster (uncoated)	X	X	✓	✓	✓	✓	✓	✓	✓	✓	✓	A	✓	X	✓	✓	✓	✓	✓	✓	✓
Ceramic tiles (cement grout)	X	X	✓	✓	✓	✓	✓	✓	✓	✓	✓	A	✓	✓	✓	✓	✓	✓	✓	✓	✓
Clay bricks (cement mortar)	X	X	✓	✓	✓	✓	✓	✓	✓	✓	✓	A	✓	✓	✓	✓	✓	✓	✓	✓	✓
Concrete old (unpainted)	✓	✓	✓	✓	✓	✓	✓	✓	✓	✓	✓	A	✓	✓	✓	✓	✓	✓	✓	✓	✓
Concrete green (unpainted)	X	X	✓	✓	✓	✓	✓	✓	✓	✓	✓	A	✓	X	✓	✓	X	X	X	X	X
Copper/brass	X	X	✓	✓	✓	✓	✓	✓	✓	✓	✓	✓	✓	✓	✓	✓	X	X	X	X	X
Glass	✓	✓	✓	✓	✓	✓	✓	✓	✓	✓	✓	✓	✓	✓	✓	✓	✓	✓	✓	✓	✓
Glazed roof tiles	✓	✓	✓	✓	✓	✓	✓	✓	✓	✓	✓	✓	✓	✓	✓	✓	✓	✓	✓	✓	✓
Lead (including lead-edged) unpainted	X	X	✓	✓	✓	✓	✓	✓	✓	✓	✓	✓	✓	✓	✓	✓	✓	✓	✓	✓	✓
Plastics	✓	✓	✓	✓	✓	✓	✓	✓	✓	✓	✓	✓	✓	✓	✓	✓	✓	✓	✓	✓	✓
Stainless steel	✓	✓	✓	✓	✓	✓	✓	✓	✓	✓	✓	✓	✓	✓	✓	✓	✓	✓	✓	✓	✓
Steel, galvanised coil-coated	✓	✓	✓	✓	✓	✓	✓	✓	✓	✓	✓	✓	✓	✓	✓	✓	✓	✓	✓	✓	✓
Steel, galvanized (unpainted)	✓	✓	✓	✓	✓	✓	✓	✓	✓	✓	✓	✓	✓	✓	✓	✓	✓	✓	✓	✓	✓
Zinc	✓	✓	✓	✓	✓	✓	✓	✓	✓	✓	✓	✓	✓	✓	✓	✓	✓	✓	✓	✓	✓
Zinc/aluminium coated ⁽¹⁾	✓	✓	✓	✓	✓	✓	✓	✓	✓	✓	✓	✓	✓	✓	✓	✓	✓	✓	✓	✓	✓
Zinc/aluminium, (unpainted)	✓	✓	✓	✓	✓	✓	✓	✓	✓	✓	✓	✓	✓	✓	✓	✓	✓	✓	✓	✓	✓

LEGEND:
 ✓ Materials satisfactory with water run-off as indicated.
 X Water run-off is not permitted as indicated.
 A Etching or staining of glass may occur with run-off.

NOTES:
 (1) Coated – includes factory-painted, coil-coated and powder-coated.
 (2) Includes copper azole and copper quaternary salts.

COMMENT:

Tables 1, 2 and 3 above show that galvanized fixings should be used rather than stainless steel when in contact with galvanized cladding and zinc/aluminium coated cladding. (This includes mounting brackets and straps.)

3.0 Solar Hot Water System Requirements

3.1 Solar water heaters and components

3.1.1 Solar *water heaters* supplied as packaged systems or custom built systems must comply with one of the following:

- AS/NZS 2712: 2007, or
- AS/NZS 2712: 2002 (up to 1 July 2009), or
- NZS 4613 (up to 1 July 2008).

3.1.2 Tanks installed as part of a pumped solar system where the tank is separately mounted from the collector must comply with the minimum tank insulation requirements of AS/NZS 4692.2.

COMMENT:

AS/NZS 4692.2 specifies Minimum Energy Performance Standard (MEPS) requirements for electric water heaters. Clause 1.4 of this standard excludes solar water heaters. Paragraph 3.1.2 of this acceptable solution modifies this exclusion so that hot water tanks mounted separately from solar collectors used in a solar water heating system must now comply with the MEPS requirements specified in AS/NZS 4692.2.

3.2 Solar controller

3.2.1 A controller to control the use of supplementary heating from a *network utility operator* satisfies NZBC Clause H1.3.4.

3.2.2 The requirements for controllers are specified in AS/NZS 2712: 2007 clause 6.3. In addition to these requirements either the controller or the solar water heater system design must minimise the use of supplementary heating from a *network utility operator* and maximise the use of solar energy, while meeting the hot water demand.

3.3 Sizing of systems

3.3.1 The ratio of tank volume to collector area must be no less than 50 litres per square metre of collector area.

COMMENT:

The 3.3.1 requirement is to prevent overheating of the system. The capacity of the tank should not be less than one day's expected use. For most houses the expected hot water consumption is 40-60 litres per person per day when stored at 60°C.

3.4 Operating and safety devices

3.4.1 Storage tanks in solar hot water systems must have operating and safety devices that meet the requirements of G12/AS1 Clause 6.

3.4.2 Water from the installed system must not discharge onto the roof. Vent pipes and outlets from pressure relief valves must be plumbed to a suitable drain point.

3.4.3 A collector, or integral collector and tank, must be able to withstand temperatures that it will encounter under all of the following conditions:

- a) When empty during installation, and
- b) When empty during its service life, and
- c) When full of water, but not being used in peak summer conditions.

3.5 Protection from legionella bacteria

3.5.1 To prevent the growth of legionella bacteria, solar water heaters must either:

- (a) include a heating element (no higher than the middle of the tank) that is connected to a continuously energised power source and a thermostat set to no less than 60°C, or
- (b) be controlled so that the temperature of the water above the element in the tank is raised by a heating element, located in the bottom 20% of the water capacity and no more than 150 mm from the bottom of the tank, to not less than 60°C once a day, or
- (c) be controlled so that all of the temperature of stored water is raised at least once a week to not less than 60°C for a period of not less than 1 hour, measured by a probe located in the bottom 20% of the water capacity and no more than 150 mm from the bottom of the tank. For open loop systems the stored water includes the water in the collector and this must be circulated through the collector during the heating period.

3.5.2 Where the solar hot water system is used as a pre-heater for an instantaneous water heater then, either:

- (a) The hot water storage tank connected to the solar collector must be fitted with supplementary heating and a controller operating to meet the conditions outlined in 3.5.1, or
- (b) The instantaneous water heater must heat all water passing through it to not less than 70°C.

3.5.3 Where the solar hot water system supplies inlet water to a storage water heater, with power source and thermostat set to no less than 60°C, no additional legionella control measures are required.

COMMENT:

Clause 3.5 of this Acceptable Solution provides ways to demonstrate that the NZBC Clause G12.3.9 (i.e. "A hot water system must be capable of being controlled to prevent the growth of legionella bacteria") is satisfied. This is a heat disinfection method which is considered the most effective method to control Legionella.

The heating required to control the growth of legionella does not necessarily have to be achieved using supplementary electric heating; it could also be achieved using gas, solar or wood as a heating fuel.

3.6 Protection from frosts

3.6.1 For protection from freezing, collectors installed in climate zones A and B (as shown in Figure 1) must:

- a) pass the level 1 test described in AS/NZS 2712: 2007 Appendix E3, or
- b) have an active freeze protection mechanism or
- c) have an automatic drain-down system.

3.6.2 For protection from freezing, collectors installed in climate zone C (as shown in Figure 1) must:

- a) pass the level 2 test described in AS/NZS 2712: 2007 Appendix E3, or
- b) have an automatic drain-down system.

4.0 Location of Solar Hot Water Systems

4.1 Location

The position of solar heating systems must be located away from the edge of a gable roof structure outside the high pressure wind zone shown in Figure 2.

Figure 2: High pressure wind zone

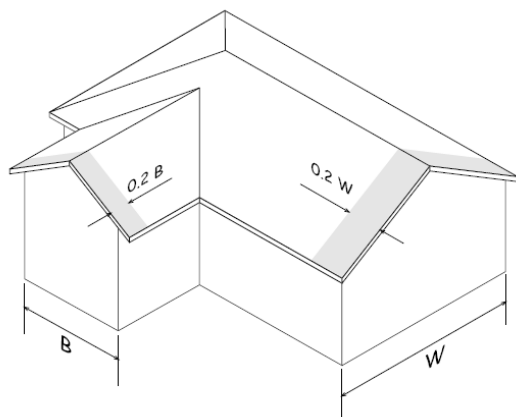

4.2 Solar orientation and inclination

4.2.1 Solar collectors must face within +/- 90 degrees of geographic north (ie between east and west) to satisfy the requirements of NZBC Clause H1.3.4(a).

4.2.2 Flat plate solar collectors must be inclined at an angle within +/- 20 degrees of the angle of latitude (from the horizontal) to satisfy the requirements of NZBC Clause H1.3.4(a).

COMMENT:

The ideal orientation of a solar collector is geographic north with an inclination angle from the horizontal the same as the angle of latitude for the location. Deviations from the ideal orientation will reduce the performance of the solar water heater.

Details of the impact of changes in orientation and inclination are provided in NZS 4614:1986, and is shown in the following diagram.

Factors for inclination and solar orientation

Direction	(degrees)	Inclination angle (degrees)					
		0°	20°	40°	60°	80°	90°
West	270	0.85	0.85	0.8	0.72	0.6	0.53
	300	0.85	0.92	0.92	0.86	0.73	0.65
	330	0.85	0.98	0.99	0.93	0.8	0.71
North	0	0.85	0.97	1	0.94	0.8	0.7
	30	0.85	0.94	0.95	0.88	0.74	0.65
	60	0.85	0.88	0.86	0.77	0.65	0.57
East	90	0.85	0.8	0.73	0.64	0.52	0.46
Good orientation		Moderate orientation			Poor orientation		

FACTORS FOR INCLINATION AND SOLAR ORIENTATION

The relative performance of flat plate collectors in different orientations is illustrated. It is clear that collectors should face within about 45° of north, and be fitted at an inclination angle between 20° and 50°.

If for some reason it were necessary to place the collectors facing the west at 60° inclination, then to avoid loss in performance, the collectors would have to be 1/0.72 (or 1.4) as large. i.e. increased by 40% in the collector area.

Where collectors other than flat-plate type (cylindrical shape for instance) are used similar optimum requirements for orientation will apply, i.e. the axis of the cylinder should be inclined at 20° to 50°. The performance loss by using poorer orientation has not been as fully explored as for the flat-plate case.

4.3 Shading

4.3.1 Although shading of solar collectors should be minimised to ensure maximum performance of the system, there is no requirement to avoid shading in this Acceptable Solution. Information on the effects of shading are detailed in the comment below, together with recommendations.

COMMENT:

Significant shading between 9:00am and 3:00pm will affect the performance of a solar water heater.

The solar altitude may be determined using a commercial "sun locator" or a simple solar altitude sight may be constructed using the diagrams given in Appendix I of AS/NZS 3500.4.

Details on the solar altitude at midwinter are provided in the following below.

Solar altitude in mid-winter

City	Latitude	9.00 am	12.00 pm	3.00 pm
	deg.	deg.	deg.	deg.
Auckland	37.0	16.1	29.5	16.1
Wellington	41.0	13.2	25.5	13.2
Christchurch	43.5	11.2	23.0	11.2
Invercargill	46.0	9.0	20.0	9.0

Note: (Source: AS/NZS 3500.4, Table I1)

5.0 Installation of Solar Systems

5.0.1 Solar hot water systems must be installed in accordance with the requirements of AS/NZS 3500 Part 4, unless modified by this Acceptable Solution.

5.0.2 Storage tanks of solar hot water systems must have drain pipes that:

- a) Have an easily reached isolating valve, and terminate with a cap or plug to empty the vessel for maintenance, or
- b) Terminate outside the *building* with a cap only.

5.0.3 Components of the solar water heating system must be separated from contact with the metal roof cladding by non-metallic, non-porous, non-corrosive packing at all points.

5.0.4 All metal swarf from drilling or cutting must be removed from the roof surface to prevent corrosion. Care must also be taken to avoid scratching of any roof cladding protective coating.

5.1 Wetback water heaters

5.1.1 Where a wetback water heater is used in conjunction with a solar hot water system, the circuits for the two heat sources must be arranged with independent piping so as not to interact hydraulically with each other.

5.1.2 Any wetback water heater circuit must be open-vented. Where a wetback is used in conjunction with a tank operating at a pressure that cannot be open-vented, the wetback must operate on an indirect loop with a heat-exchanger to transfer heat from the low-pressure wetback to the higher-pressure domestic supply.

5.2 Weathertightness

5.2.1 Any penetrations made in the *building* cladding during the installation of a solar system, must be flashed or sealed to provide adequate resistance to penetration by, and the accumulation of, moisture from the outside.

5.2.2 Where roof penetrations are required for large openings such as solar collectors installed in or below the roof:

- a) the edge of roofing penetrations over 200 mm wide must be supported in either direction with additional framing as shown in Figure 3, and
- b) for the catchment area of the roof above the penetration as shown in Figure 4, the roof length must be limited to the areas shown in Table 5.

Table 5

Maximum catchment areas above penetrations greater than 200 mm wide

Penetration width	Maximum roof length above penetrations in metres			
	Profiled metal			
	Corrugated	Trapezoidal	Trough profile	Other roofs
800 to 1200 mm	4 m	8 m	16 m	4 m
600 to 800 mm	6 m	12 m	18 m	6 m
400 to 600 mm	8 m	16 m	18 m	8 m
200 to 400 mm	12 m	18 m	18 m	10 m

Figure 3: Support for Penetration greater than 200 mm wide

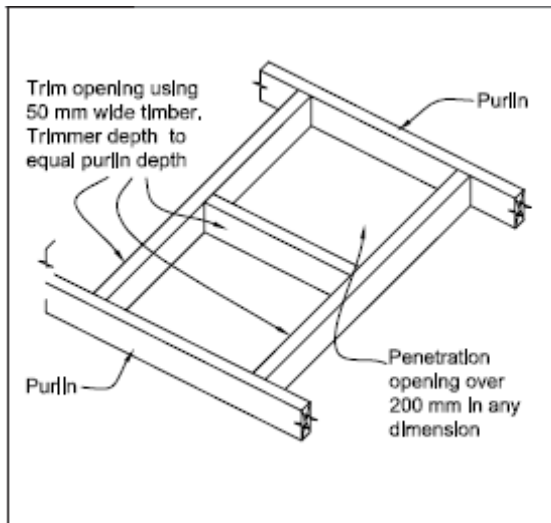
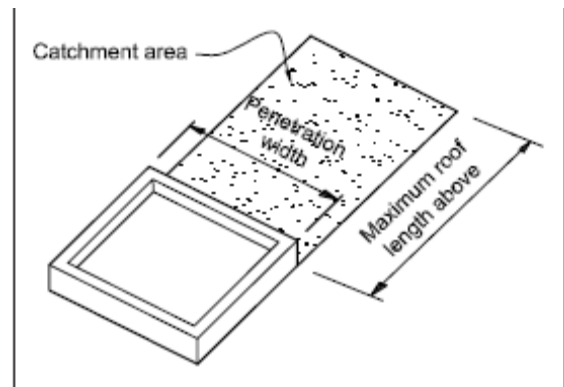

Figure 4: Catchment area for penetrations greater than 200 mm wide – see table 5

Note: Profiled metal roofing refer to Table 5 for maximum roof lengths above penetrations



5.2.2 Masonry Tile Roof

Figure 5: Pipe penetration for masonry tile roof

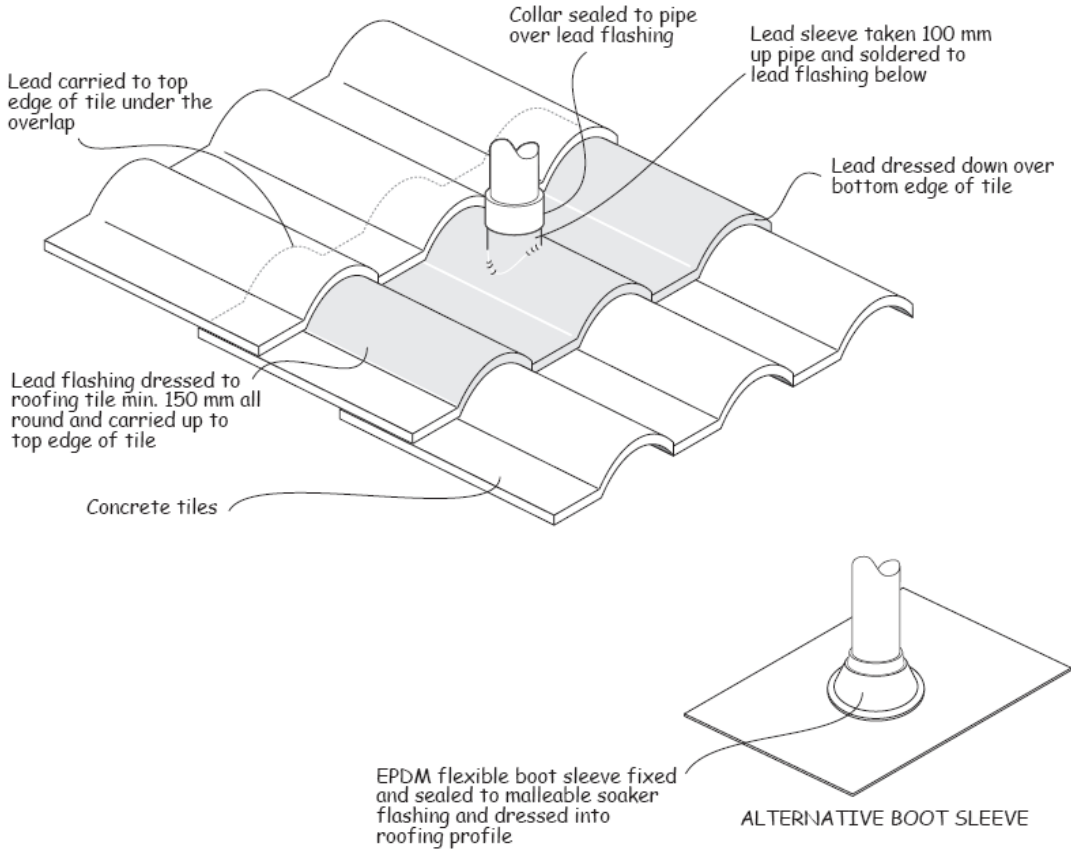

5.2.3 Pipe penetrations in pressed metal tile roofs must be flashed using EPDM or silicone rubber boot flashings as shown in Figure 6

5.2.4 Roof penetrations in profiled metal roofs must be flashed as follows:

a) Pipe penetrations up to 60 mm must be flashed using an EPDM boot flashing as shown in Figure 6, and

b) Rectangular penetrations up to 1200 mm wide must be flashed using a soaker type flashing as shown in Figure 7.

5.2.5 Penetrations on roofs will require specific design when:

a) the pitch of less than 15° , or

b) penetrations larger than 60 mm, or

c) penetrations requiring specialised or complex flashings unless a soaker flashing is used.

COMMENT:

The New Zealand Metal Roof and Wall Cladding Code of Practice provide additional guidance.

Figure 6: Flashing for pipes cables and other penetrations

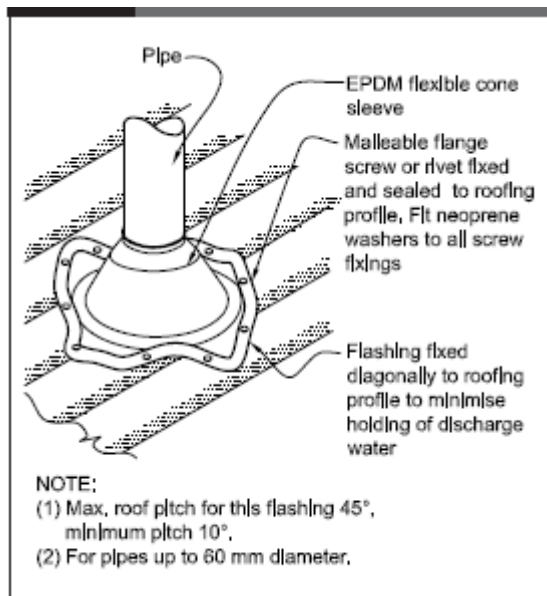
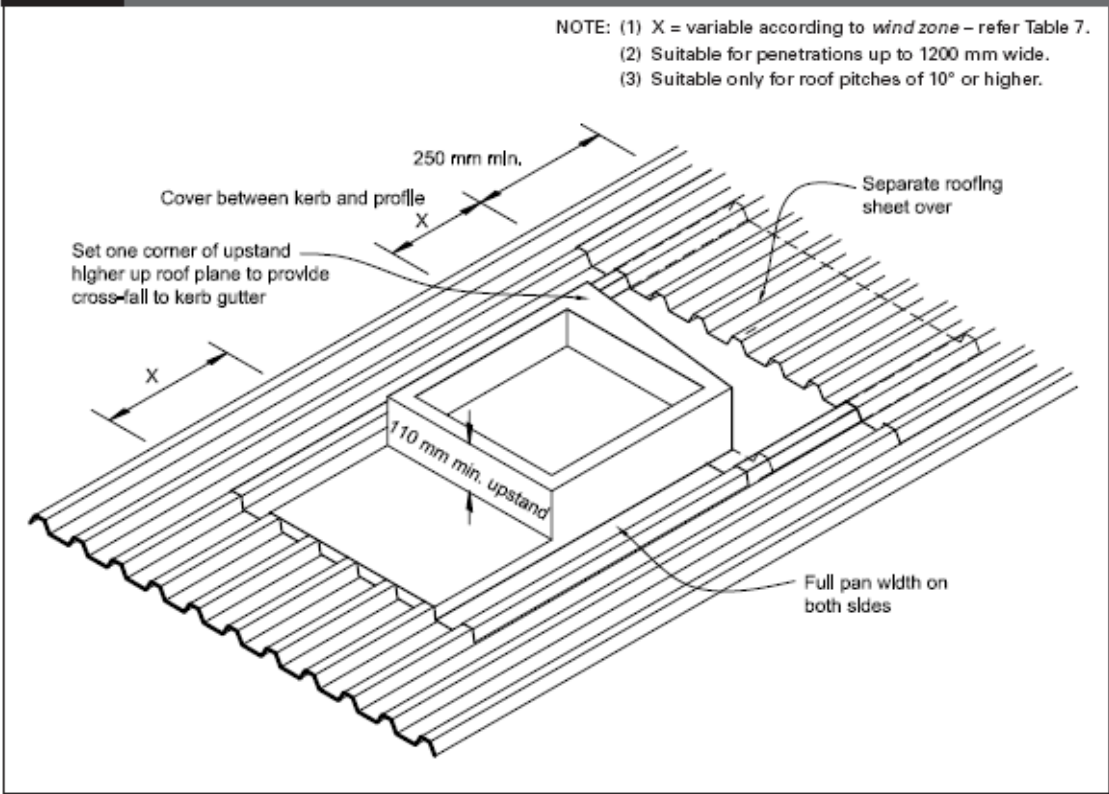
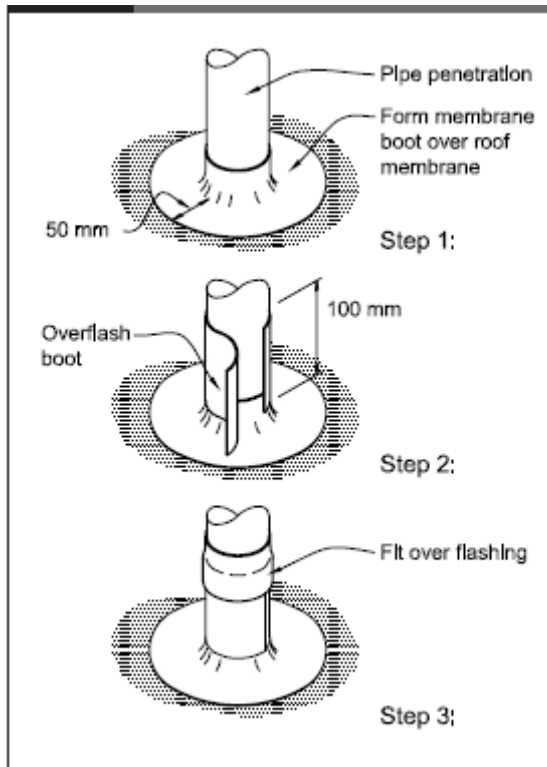

Figure 7: Soaker flashings for penetrations



5.2.6 Penetrations through membrane roofs and decks must be as shown in Figure 8

Figure 8: Pipe penetration in membrane



5.2.7 Sealant used in the installation of solar water heating system must be a neutral cure silicone sealant and must be used in conjunction with mechanical fasteners. The sealant must comply with:

i) Type F, Class 2OLM or 25LM of ISO 11600, or

ii) low modulus Type II Class A of Federal Specification TT-S-00230C.

5.2.8 Acetic cured silicone sealants may be used with stainless steel but must not be used on zinc or aluminium-zinc coatings.

5.2.9 Sealants used on roof penetrations must not be used as the primary method of excluding the ingress of moisture. Metal joints must be designed to allow the discharge of water in the absence of any sealant.

COMMENT:

One method of flashing penetrations through roofs for electrical conduits or fittings is shown below.

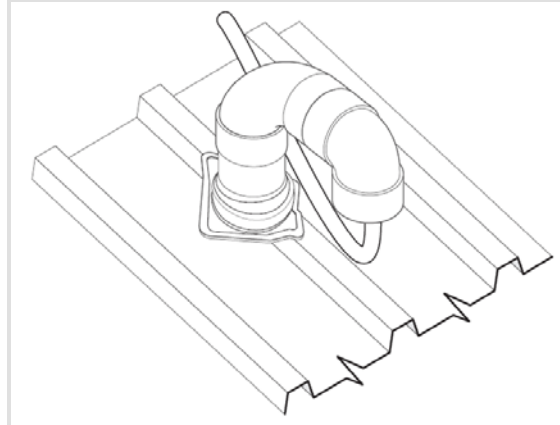

The diameter of the conduit should be the minimum practicable diameter to suit the cable size and any electrical regulatory requirements.

Alternatively a nylon cable gland can be used on the flat part of a profiled metal roof.

Other methods can also be used that meet the electrical regulatory requirements and are weather tight.

5.3 Pipe installation

5.3.1 Pipes and their supports must be electrochemically compatible or be electrically separated.

5.3.2 Pipes must be installed and supported to permit thermal movement, except where anchor points are necessary.

5.3.3 Water supply pipe work, above ground, must be supported at centres of no greater than those given in G12/AS1, Table 7: Water Supply Pipework Support Spacing.

5.3.4 Where closed cell elastomeric pipe insulation is used this must be painted or have another form of protection to prevent rapid deterioration due to exposure to UV radiation. Pipe insulation must be protected and must have a *durability* of not less than 5 years.

6.0 Structural support for solar heating systems

6.1 Scope

6.1.1 See paragraph 1.0 of this Acceptable Solution to determine when these structural and fixing requirements can be used.

6.2 Support

6.2.1 Installation on roofs must not produce restrictions to rainwater flow that enables water to accumulate or pond.

6.2.2 Solar collectors installed above metal roofs must have clearance between the collector and metal roof to avoid the accumulation of water or organic matter. On corrugated metal roofing the clearance between the collector and the top of the corrugations must be no less than 25 mm.

6.2.3 In coastal and geothermal zones defined in NZS 3604, and in locations adjacent to industrial areas clearance of 50 mm must be provided to allow access from at least 50% of the system's perimeter to wash the cladding under solar collectors.

6.2.4 Clearances must be provided to allow access to and replacement of, all serviceable components.

6.2.5 The only point of contact between a solar heating system and metal roof cladding should be where penetrations are made and these must be sealed in accordance with Paragraph 5.

6.2.6 The load of the solar system must be carried by the *building* structure. The solar collector must be fixed directly to the building structure and not to the cladding. Means of mounting are shown in Figures 9, 10, 11 and 12.

COMMENT:

Care must be taken to avoid distortion of metal cladding material.

The susceptibility for concrete and clay tiles to break means that special care must be taken when working on and attaching systems to these roofs.

Many manufacturers and installers have developed proprietary mounting systems that may have equivalent performance to this Acceptable Solution.

Figure 9: Panel bolt fixing

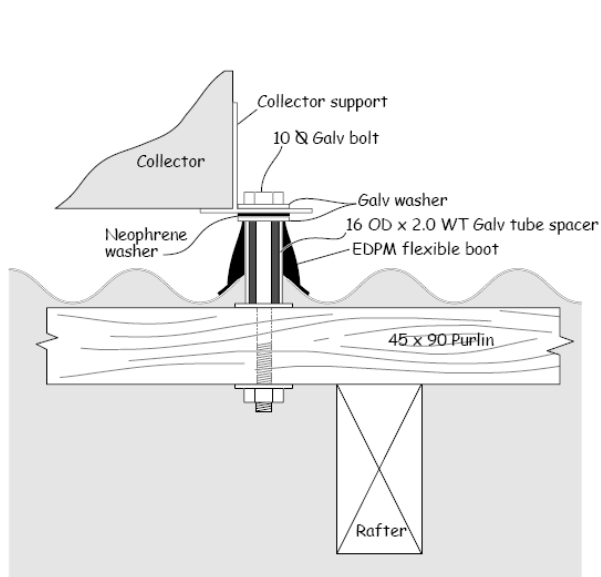

Figure 10: Panel screw fixing

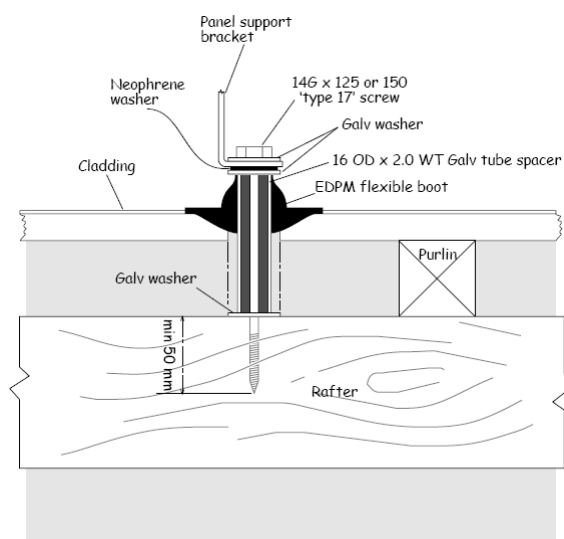

Figure 11: Panel stud fixing

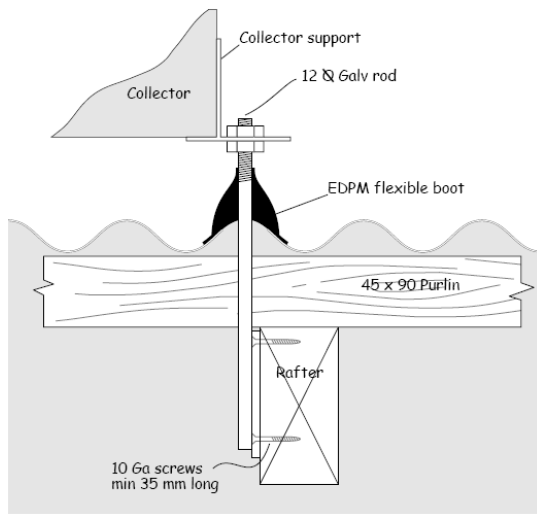
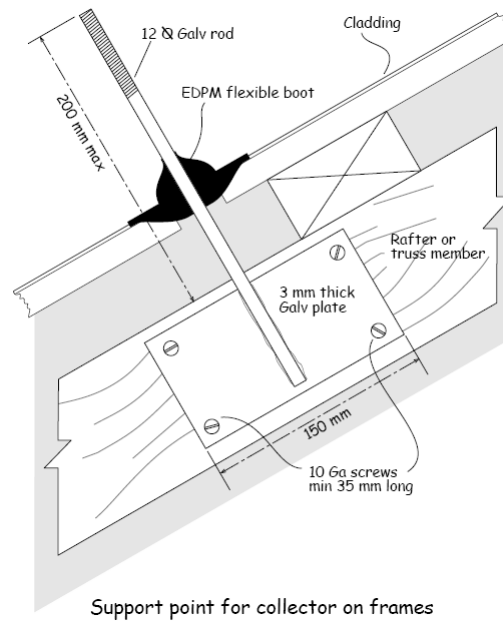

Figure 12: Panel stud fixing



6.2.7 All solar collectors must be fixed at no less than 4 points.

6.2.8 Solar collectors with an area of up to 4m², may be fixed with: 14 gauge screws in accordance with Figure 10 into the centre of one of:

(a) 14 gauge screws in accordance with Figure 10 into:

(i) purlins 70 x 45 mm or larger, that span no more than 900mm, or

(ii) purlins 90 x 45 mm or larger, that span no more than 1 100mm, or

(iii) rafters, or

(iv) truss top chords

(b) 10mm galvanised bolts in accordance with Figure 9 to purlins 90 x 45 mm or larger that span no more than 1100mm

(c) 10mm galvanised bolts welded to 3mm galvanised plate in accordance with Figures 11 or 12 to either:

(i) rafters, or

(ii) truss top chords.

6.2.9 Where solar collectors with an area of greater than 4m² to be installed, each group of

panels with an area of up to 4m² is to be separated from other groups by:

(a) At least one rafter or truss spacing along the roof, and

(b) By at least one purlin space up the roof slope

6.2.10 Where collectors are mounted together or separately on a frame, the frames must meet the requirements described in Paragraph 6.5.

6.3 Alteration of roof structure for installation

6.3.1 Rafters, purlins and truss members may not be cut, drilled, notched or otherwise reduced in strength except for drilling for the attachment of collectors or tanks.

6.4 Mounting of solar systems

6.4.1 Where solar collector panels are mounted above roof cladding, they must be mounted so that the weight of the panels is:

(a) transferred directly to underlying rafters or trusses with connections conforming with paragraphs 6.2.9 or 6.2.10, or

(b) transferred directly to underlying purlins conforming to Paragraph 6.2.8, and

(c) carried by collector support battens conforming to Paragraph 6.5.

6.4.2 All fixings that pierce metal sheeting must be provided with adequate sealing washers or boots to prevent leakage.

6.4.3 When used with steel roof cladding, fixings must be zinc coated or galvanised.

COMMENT:

The fixing types and product must be in accordance with the requirements for fixing used on normal roofing installations.

For additional guidance on selection and application of fastenings refer to the NZ Metal Roof and Wall Cladding Code of Practice.

6.5.3 Collector support battens running horizontally across the roof slope, as shown in Figure 13, must be in one piece and be at least long enough to span each space between rafters or trusses that have a collector panel above them. Battens may cantilever up to 200 mm beyond a rafter or truss. The collector support battens are to be fixed using the details given in Figures 9, 10, 11 and 12 to either:

- (a) each rafter or truss that they cross, or
- (b) To purlins provided the purlins are a minimum size of 90 x 45 mm on their flat and span a maximum of 1100mm.

6.5 Collector support battens

6.5.1 Collector support battens may either:

- (a) run horizontally across the slope of the roof as provided for in Paragraph 6.5.3 and Figure 13, or
- (b) run up the slope of the roof as provided for in Paragraph 6.5.4 and Figure 14.

6.5.2 Where the collector is mounted on collector support battens the battens must be constructed of one of the following:

- (a) galvanised mild steel with a minimum section moment of inertia of 0.45 cm^4 , or
- (b) stainless steel with a minimum section moment of inertia of 0.45 cm^4 , or
- (c) aluminium with a minimum section moment of inertia of 1.3 cm^4 .

COMMENT:

A steel angle section 30 x 30 x 3 mm or an aluminium channel section 25 x 25 mm with 3 mm wall thickness meets the minimum stiffness requirements of Paragraph 6.5.2.

Figure 13: Collector support battens across roof slope

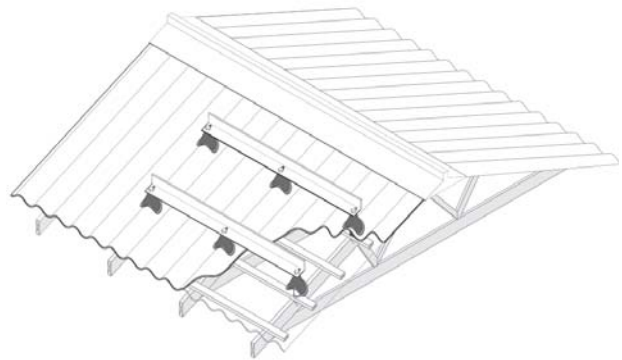

6.5.4 Where the collector is laid on collector support battens running up the slope of the roof those collector support battens must be supported as shown by Figure 14 by either:

- 1) each purlin crossed of a minimum size of 90 x 45 mm on their flat using the connection details given by Figure 9, or
- 2) by a rafter or truss top chord at not more than 1500 mm centres and within 300 mm of each end using the connection details given by Figure 10 or by Figures 11 and 12, and

(b) Be in one piece

Figure 14: Collector frame up slope of roof

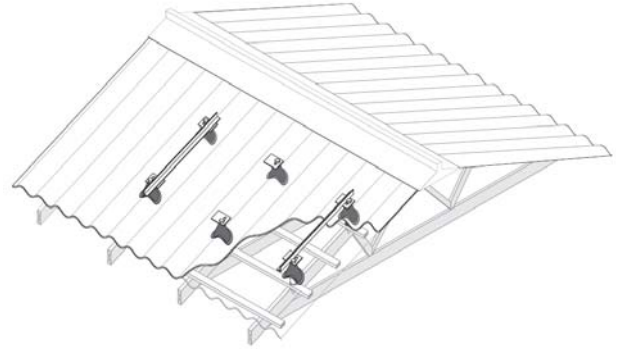

7.0 Maintenance and Durability

7.1 Maintenance

7.1.1 Systems should be installed so that they can be easily maintained and owners must be provided with adequate instructions on the maintenance required. A permanent label must be fixed to a prominent part of the system which describes the key maintenance and operating requirements of the system including any markings required in the appropriate Standard identified in Paragraph 3.1.1.

COMMENT

Maintenance should be carried out as necessary to achieve the required operating performance of the solar water heater over the life of the system and the *durability* of solar water heating system and any affected *building* components and junctions.

The extent and nature of necessary maintenance is dependent on the:

- (a) Type of solar water heater system,
- (b) Materials and components used in the system manufacture and installation,
- (c) Position of solar water heating system on the *building*,
- (d) Geographical location of the *building*, and
- (e) Specific site conditions.

COMMENT:

Washing by rain removes most accumulated atmospheric contaminants from roof cladding, but sheltered areas, below solar systems, may be protected from the direct effects of rain and therefore require regular manual washing. It is important that high pressure water used in manual washing is not directed at sensitive junctions such as penetrations and other *flashings*. Care must be taken to avoid water being driven past anti-capillary gaps and *flashings*.

7.2 Durability

7.2.1 Solar water heating systems and their components must meet the *durability* requirements specified in NZBC Clause B2.

7.2.2 A solar water heating system is easy to access and moderately difficult to replace and therefore the *durability* requirement is 15 years.

7.2.3 Some components of the system will require maintenance and/or replacement. Components requiring maintenance or replacement before 15 years must be identified in the owner's manual.

COMMENT:

This *durability* requirement is consistent with NZS 4613 which states:

"All materials used in the construction of solar equipment must have an expected in-service life of at least 15 years unless specifically excluded by the manufacturer." (clause 103.2) and

"Collectors must have an expected service life of at least 15 years with no loss of fitness for purpose or rapid degradation during this period." (clause 104.1)

G12/AS1 has required that solar water heating systems comply with NZS 4613 since the NZBC came into effect in 1992.